

DuPont Flashing Products Installation Guidelines

Integral Flanged Windows with Recessed Openings
Installed **AFTER** the DuPont™ Tyvek® Water-Resistive
and Air Barrier (WRB)

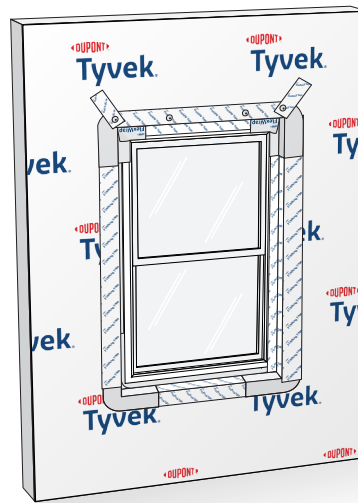

For Single-Family Residential and
Wood-Framed Multi-Family/Light
Commercial Buildings



Shallow

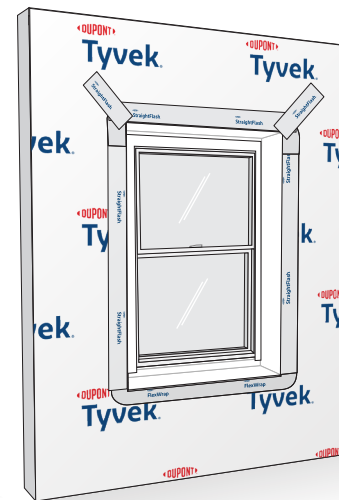

Hybrid

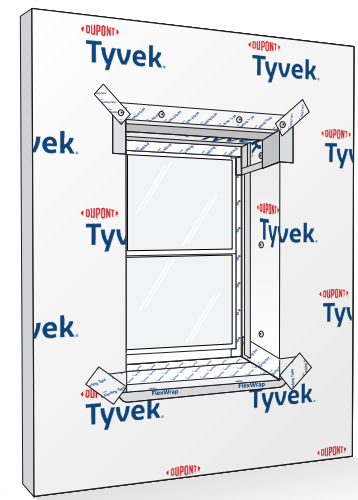

Deep

Table of Contents

Introduction.....	3	Hybrid Installation Methods for DuPont Self-Adhered Flashing Products and DuPont™ Tyvek® Fluid Applied Products Installed AFTER the DuPont™ Tyvek® WRB ...	34
Applicable Products	3	Integral Flanged Window with Shallow (Up to 4”) Recessed Opening.....	34
Additional Materials Based on Project Requirements, Details, and Specifications.....	4	Method 1: Using “Wrap the Cavity” Method along Edge of Rough Opening with DuPont Self-Adhered Flashing Products and DuPont™ Tyvek® Fluid Applied Flashing and Joint Compound+	34
Warranty.....	4	Method 2: Using Single Pieces of DuPont™ FlexWrap™ at the Sill and Head with DuPont™ Tyvek® Fluid Applied Flashing and Joint Compound+	43
Applicable Structures and Performance Criteria.....	5	Installation Methods for DuPont Self-Adhered Flashing Products Installed AFTER the DuPont™ Tyvek® WRB	54
Flashing Products Code Requirements.....	8	Integral Flanged Window with Deep (Greater than 4”) Recessed Opening.....	54
Water-Resistive Barrier (WRB) Code Requirements.....	8	Method 1: Depth of Recess Less Than 1/2 the Width of the Recess	55
Additional Codes and Standards Information for DuPont™ Tyvek® Commercial Air and Water Barrier Systems.....	9	Method 2: Depth of Recess Greater Than 1/2 the Width of the Recess.....	65
General Instructions.....	9	Product Composition and UV Stability.....	77
Special Considerations.....	9	Design Considerations.....	77
Key Installation Requirements for Drainable Window/Door Installation	12	Safety and Handling.....	77
Fabricating DuPont™ FlexWrap™ Recessed Window Corners	13	Warning.....	77
Alternate Installation Considerations	16	Caution.....	78
Installation Methods for DuPont Self-Adhered Flashing Products Installed AFTER the DuPont™ Tyvek® WRB	17	Hazard Statement.....	78
Integral Flanged Window with Shallow (Up to 4”) Recessed Opening.....	17	For More Information.....	78
Field Preparation of Recessed Window Corner Using DuPont™ FlexWrap™	17		
Method 1: Using DuPont™ FlexWrap™ Recessed Window Corners at the Sill.....	18		
Method 2: Using Single Pieces of DuPont™ FlexWrap™ at the Sill and Head.....	25		

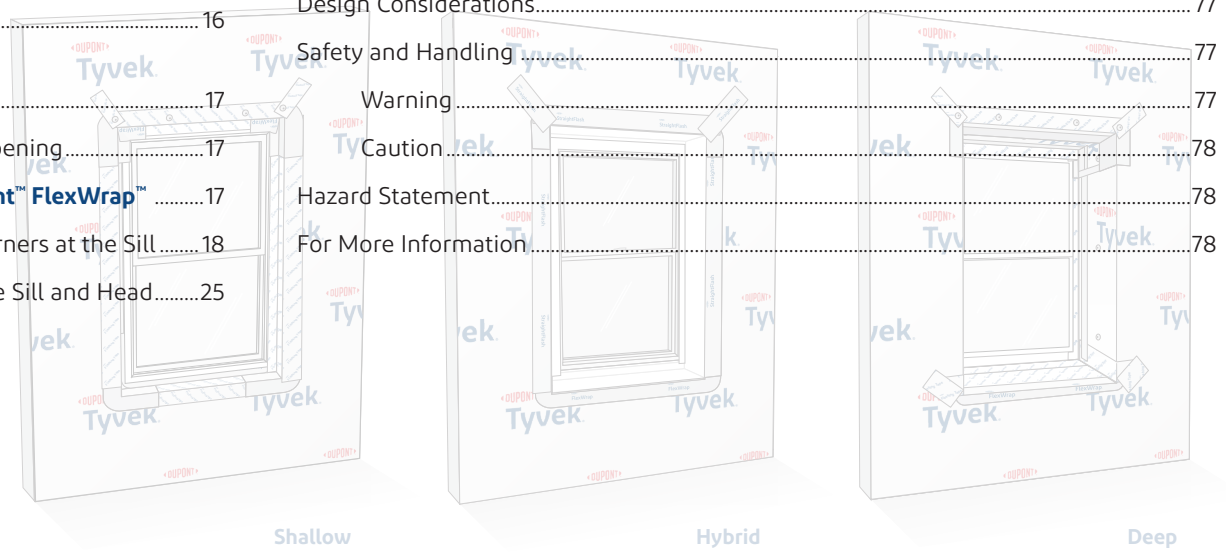

Introduction

This Installation Guideline pertains to wood-framed buildings of any height of Type III and Type V construction, including single-family homes, multi-family buildings and light commercial buildings. See [Applicable Structures and Performance Criteria](#) for more information regarding building types and building envelope performance.

This Installation Guideline outlines recommended installation techniques and details for bump-out conditions with **DuPont Self-Adhered Flashing Products** installed **AFTER** **DuPont™ Tyvek® Water Resistive and Air Barriers**, referred to in this document as **DuPont™ Tyvek® WRBs**. This includes **DuPont™ Tyvek® HomeWrap®**, **Tyvek® StuccoWrap®**, **Tyvek® DrainWrap™**, **Tyvek® CommercialWrap®** and/or **Tyvek® CommercialWrap® D**. Where applicable, **DuPont™ Tyvek® Fluid Applied Products** are shown installed in conjunction with **Tyvek® WRBs** in hybrid conditions. Both **Tyvek® WRBs** and **Tyvek® Fluid Applied Products** meet or exceed the requirements of a water-resistive barrier as defined in the 2018 International Building Code (IBC).

Always check building.dupont.com for the latest versions of DuPont Installation Guidelines and other product literature.

Applicable Products

Water-Resistive and Air Barriers (Tyvek® WRBs)

Product	Dimensions	Area
DuPont™ Tyvek® HomeWrap®	3 ft x 100 ft	300 sq ft
	3 ft x 165 ft	495 sq ft
	5 ft x 200 ft	1,000 sq ft
	9 ft x 100 ft	900 sq ft
	9 ft x 150 ft	1,350 sq ft
	10 ft x 100 ft	1,000 sq ft
DuPont™ Tyvek® StuccoWrap®	10 ft x 150 ft	1,500 sq ft
	5 ft x 200 ft	1,000 sq ft
DuPont™ Tyvek® DrainWrap™	5 ft x 200 ft	1,000 sq ft
	10 ft x 125 ft	1,250 sq ft
DuPont™ Tyvek® CommercialWrap®	9 ft x 125 ft	1,125 sq ft
	10 ft x 125 ft	1,250 sq ft
DuPont™ Tyvek® CommercialWrap® D	5 ft x 200 ft	1,000 sq ft
	10 ft x 125 ft	1,250 sq ft

Fluid Applied Products

Product	Quantity
DuPont™ Tyvek® Fluid Applied WB+™	5 gal, 50 gal
DuPont™ Tyvek® Fluid Applied Flashing and Joint Compound+	28 oz, 3.5 gal

Self-Adhered Flashing Products

Product	Width
DuPont™ FlexWrap™	6 in
	9 in
DuPont™ StraightFlash™	4 in
	9 in
DuPont™ Flashing Tape	4 in
	6 in
	9 in
	12 in

Installation Accessories

Product	Type	Quantity
DuPont™ Tyvek® Tape	2 in Bulk Pack	6 rolls/bulk pack
	3 in Bulk Pack	
DuPont™ Tyvek® Wrap Cap Staples or other cap staples for Stinger® Cap Stapler	7/8 in, 1-1/4 in, and 1-1/2 in lengths	2,000/box
	3/8 in and 5/8 in lengths	2,016/box
DuPont™ Tyvek® Wrap Cap Nails	1 in electro-galvanized ring shank nail	2,000/box
DuPont™ Tyvek® Wrap Cap Screws	2 in dia. plastic cap, 1-3/4 in screw length	1,000/box
Great Stuff Pro™ Window & Door Polyurethane Foam Sealant	Can (reusable dispensing gun sold separately)	20 oz
Great Stuff Pro™ Gaps & Cracks Polyurethane Foam Sealant	Can (reusable dispensing gun sold separately)	20 oz
DuPont™ RainVent™ Battens	5/8 in x 3/8 in x 8 ft	40/pack
DuPont™ Tyvek® DrainVent™ Rainscreen	4 ft x 50 ft roll	
Tower® Residential Sealant (formerly DuPont™ Residential Sealant)		
TRUFAST® Walls Grip-Deck® screws with Thermal-Grip FastCap™ washers (TRUFAST® Walls formerly Rodenhouse)¹		

¹For information regarding installation of TRUFAST® Walls fasteners, refer to the applicable **Tyvek® WRB** Installation Guideline that can be found on building.dupont.com.

Additional Materials Based on Project Requirements, Details, and Specifications¹

- Backer Rod
- Sealant²
- Adhesive/Primer²
- Brushes for Surface Preparation
- J-Roller
- Trowels

Warranty

Please refer to the [*DuPont Building Envelope Solutions Products 10-Year Limited Warranty for Single-Family, Wood-Framed Multi-Family, and Light Commercial Buildings.*](#)

NOTE: In order to make a claim under the DuPont Performance Building Solutions 10-Year Limited Product and Labor Warranty, you must have met all of the terms and conditions of the warranty, including use of the applicable DuPont Installation Guidelines available at the date of original installation. In the event that a specific detail or installation technique is not covered in the DuPont Installation Guidelines at the time of construction, then the Key Installation Requirements outlined in this document must have been followed in order to make a claim under the warranty. It is in the sole discretion of DuPont to determine if full compliance with the Key Installation Requirements exists. Please contact DuPont or a DuPont Representative if you have any questions regarding any DuPont Installation Guideline.

¹Apply per manufacturers' guidelines. **For non DuPont products, DuPont assumes no liability in use of recommended products** — installers need to evaluate suitability of recommended products in their end-use applications.

²For information regarding chemical compatibility of sealants, see technical bulletin [*Chemical Compatibility of Representative Building Sealants and Adhesives/Primers.*](#)

Applicable Structures and Performance Criteria

Applicable Structures

These Installation Guidelines pertain to Single-Family Residential, and Wood-Framed Multi-Family and Light Commercial Buildings as defined below.

DuPont categorizes structures into three primary groups:

- i.) **“Single-Family Residential Buildings”** are defined as fully-detached one or two family structures, as well as townhouse structures not more than three stories above grade plane as defined in the 2018 International Residential Code (IRC) Section R101.2, both to the extent they are exclusively Residential Use building structures.
- ii.) **“Wood-Framed Multi-Family and Light Commercial Buildings”** are defined as the following (must meet **ALL** criteria):
 - a. Constructed of wood-based structural exterior framing of Type III or Type V Construction* (International Building Code (IBC) (Chapter 6)); and
 - b. Does not exceed 2018 IBC max height (Table 504.3) for Type V construction (70 ft.) or Type III construction (85 ft.), including allowances for Automatic Sprinkler height increase (IBC 504.1 and Table 504.4) and ‘podium’ structures outlined in the Special Provisions* (IBC Section 510); and
 - c. Design requirements for the building envelope do not exceed air barrier performance of ASTM E1677 (10.8 psf structural load, 65 mph equivalent wind load), and water infiltration resistance criteria of 6.24 psf (50 mph equivalent wind-driven rain) when tested in accordance with ASTM E331, ASTM E1105, or equivalent.
- iii.) **“Commercial and High-Performance Buildings of Any Height”** can be defined as any of the following:
 - a. Structures constructed of steel-based structural exterior framing and any exterior sheathing, or
 - b. Structures with exterior above grade walls constructed of concrete or concrete masonry units (CMU), or
 - c. Structures of any height and construction type (including any framing type) that are designated as high-performance. “High-performance” is defined as air barrier performance exceeding ASTM E1677 and/or water infiltration resistance criteria exceeding 6.24 psf when tested in accordance with ASTM E331, ASTM E1105, or equivalent.

*Special Provisions (IBC Section 510) allows for a “horizontal building separation”, or ‘podium’, to be built under the wood-framed Type III or Type V building. The podium is typically constructed of steel framing or concrete. Podium-style buildings are included under “Wood-Framed Multi-Family and Light Commercial Buildings”, as long as all other definition criteria (a. through c. above) are met.

NOTE: “Podium” style structures with wood-framed floors built above steel-framed or concrete/CMU floors are covered under “Wood-Framed Multi-Family and Light Commercial Buildings” unless they are “high-performance”.

Water-Resistive Barrier Performance Requirements

These Installation Guidelines pertain to single family residential, wood-framed multi-family and light commercial buildings with air barrier performance not exceeding ASTM E1677 (10.8 psf structural load, 65 mph equivalent wind load), and water infiltration resistance criteria not exceeding 6.24 psf (50 mph equivalent wind-driven rain) when tested in accordance with ASTM E331, ASTM E1105, or equivalent.

Buildings with high-performance air barrier designs are defined by DuPont as those with air barrier performance equivalent to ASTM E2357 (or other exceeding ASTM E1677), and/or water infiltration resistance criteria greater than 6.24 psf when tested in accordance with ASTM E331, ASTM E1105, or equivalent.

Allowable Building Height and Number of Stories

Chapter 5 of the 2018 IBC contains information regarding the maximum height and number of stories for buildings of Group R Occupancy Classification (IBC Section 310). Including increased allowances for automatic sprinklers and a “podium” horizontal building separation (Section 510), Group R buildings of Type III or Type V construction can have the following **maximum heights above grade plane**:

Buildings with Group R (Residential) Occupancy Classification

Type of Construction	Maximum Building Height in Feet Per 2018 IBC Table 504.3
VA	70
VB	60
IIIA	85
IIIB	75

For Wood-Framed Multi-Family and Light Commercial Buildings up to 70 feet in height, any DuPont™ Tyvek® WRB can be used. For buildings between 70 and 85 feet in height, DuPont™ Tyvek® CommercialWrap® or DuPont™ Tyvek® CommercialWrap® D must be used on all above grade wood-framed exterior walls, and 3” Tyvek® Tape must be used.

NOTE: In general, **Tyvek® CommercialWrap®** or **Tyvek® CommercialWrap® D** are recommended for Wood-Framed Multi-Family and Light Commercial Buildings due to their increased durability and UV exposure limit which can help accommodate longer construction times. See [Product Composition and UV Stability](#) section for more information.

Applicable Structures and Performance Criteria

DuPont Building Envelope Solutions Products Installation Considerations for Single-Family Residential Buildings

These Installation Guidelines should be used for buildings which meet the applicable structures definitions and performance criteria on the previous page. The following table provides a summary of typical installation information.

Installation Considerations	Non-Air Barrier Installations (water details only)	Air Barrier Installations
Tyvek® WRB	DuPont™ Tyvek® HomeWrap®, Tyvek® DrainWrap™, Tyvek® StuccoWrap®, Tyvek® CommercialWrap®, and Tyvek® CommercialWrap® D	
DuPont™ Tyvek® Fluid Applied Products	Can be used on any above grade exterior wall where specified in hybrid details in this guide. Recommended for use on above grade exterior CMU and/or concrete walls. Refer to the DuPont™ Tyvek® Fluid Applied WB+™ and DuPont Flashing Products Installation Guidelines for additional information.	
DuPont™ Tyvek® Tape	2" (3" required when using Tyvek® DrainWrap™, Tyvek® StuccoWrap®, or Tyvek® CommercialWrap® D)	
Typical Recommended Fasteners and Spacing¹	1" DuPont™ Tyvek® Wrap Cap Staples or Nails (or equivalent) fastened along stud lines spaced at 6"– 18" vertically	
Tyvek® WRB Top of Wall Termination	Skip-sealing along top of wall using Tower® Residential Sealant, a recommended sealant ² , or Tyvek® Tape	Full seal along top of wall using Tower® Residential Sealant, a recommended sealant ² , or Tyvek® Tape .
Tyvek® WRB Bottom of Wall Termination	Skip-sealing along bottom of wall using Tower® Residential Sealant, a recommended sealant ² , or Tyvek® Tape	Full seal along bottom of wall using Tower® Residential Sealant, a recommended sealant ² , or Tyvek® Tape .
Recommended Window/Door Head Flap Treatment	Skip-sealing along horizontal edge using Tyvek® Tape is acceptable	Full seal along horizontal edge and 45° cuts using Tyvek® Tape .

¹For increased holding power and for higher air and water holdout performance, DuPont recommends fasteners of sufficient length to penetrate securely into the stud. Temporary Fastening methods can be used. For more information, refer to the applicable **Tyvek® WRB** Installation Guideline that can be found on building.dupont.com.

²For information regarding chemical compatibility of sealants, see technical bulletin [Chemical Compatibility of Representative Building Sealants and Adhesives/Primers](#).

Applicable Structures and Performance Criteria

DuPont Building Envelope Solutions Products Installation Considerations for Wood-Framed Multi-Family and Light Commercial Buildings

These Installation Guidelines should be used for buildings which meet the applicable structures definitions and performance criteria on the previous page. The following table provides a summary of typical installation information.

Installation Considerations	Total Building Height Above Grade Plane ¹	
	70 Feet and Under	70 – 85 Feet
Performance Criteria	Building air barrier performance not exceeding ASTM E1677, AND WRB and self-adhered flashing water infiltration resistance criteria not exceeding 6.24 psf when tested in accordance with ASTM E331, ASTM E1105, or equivalent.	
Tyvek® WRB²	DuPont™ Tyvek® HomeWrap®, Tyvek® DrainWrap™, Tyvek® StuccoWrap®, Tyvek® CommercialWrap®, and Tyvek® CommercialWrap® D	Tyvek® CommercialWrap®, Tyvek® CommercialWrap® D (required on all above grade wood-framed exterior walls)
DuPont™ Tyvek® Fluid Applied Products	Can be used on any above grade exterior wall where specified in hybrid details in this guide. Recommended for use on above grade exterior CMU and/or concrete walls. Refer to the DuPont™ Tyvek® Fluid Applied WB+™ and DuPont Flashing Products Installation Guidelines for additional information.	
DuPont™ Tyvek® Tape	2" (3" required when using Tyvek® DrainWrap™, Tyvek® StuccoWrap®, or Tyvek® CommercialWrap® D)	3"
Typical Recommended Fasteners and Spacing³	1" DuPont™ Tyvek® Wrap Cap Staples or Nails (or equivalent) fastened along stud lines spaced at 6" – 18" vertically	2" DuPont™ Tyvek® Wrap Cap Screws or approved TRUFAST® Walls Fasteners (formerly Rodenhouse) 1" plastic cap fasteners are considered temporary fasteners
Air Barrier Details	Required when the designated building envelope performance requirements are equivalent to ASTM E1677	
Tyvek® WRB Terminations to Sheathing	DuPont Self-Adhered Flashing Products	
Self-Adhered Flashing Patches behind Cladding Fasteners	Required when water infiltration resistance criteria for the building envelope exceeds 0.56 psf (15 mph equivalent wind-driven rain), nominal test pressure per ASTM E1677.	
Recommended Window/Door Head Flap Treatment	DuPont™ Tyvek® Tape or DuPont Self-Adhered Flashing Products	DuPont Self-Adhered Flashing Products Install mechanical fasteners through flashing as needed for increased holding power

¹Height above grade plane based on the approved calculation method as defined in architectural plans/construction documents.

²Buildings requiring NFPA 285 compliance must use **Tyvek® CommercialWrap®** or **Tyvek® CommercialWrap® D** in accordance with [DuPont NFPA 285 documentation](#).

³For increased holding power and for higher air and water holdout performance, DuPont recommends fasteners of sufficient length to penetrate securely into the stud. Temporary Fastening methods can be used. For more information, refer to the applicable **Tyvek® WRB** Installation Guideline that can be found on [building.dupont.com](#).

Flashing Products Code Requirements

The 2018 International Residential Code (Section R703.4 Flashing) requires that “approved corrosion-resistant flashing shall be applied shingle-fashion in a manner to prevent entry of water into the wall cavity or penetration of water to the building structural framing components. Self-adhered membrane used as flashing shall comply with **AAMA 711**. Fluid-applied membranes used as flashing in exterior walls shall comply with **AAMA 714**. The flashing shall extend to the surface of the exterior wall finish.

The 2018 International Building Code (Section 1404.4 Flashing) requires that “flashing shall be installed in such a manner so as to prevent moisture from entering the wall or to redirect that moisture to the exterior. Flashing shall be installed at the perimeters of exterior door and window assemblies, penetrations and terminations of exterior wall assemblies, exterior wall intersections with roofs, chimneys, porches, decks, balconies and similar projections and at built-in gutters and similar locations where moisture could enter the wall. Flashing with projecting flanges shall be installed on both sides and the ends of copings, under sills and continuously above projecting trim. Where self-adhered membranes are used as flashings of fenestration in wall assemblies, those self-adhered flashings shall comply with **AAMA 711**. Where fluid applied membranes are used as flashing for exterior wall openings, those fluid applied membrane flashings shall comply with **AAMA 714**.”

DuPont Self-Adhered Flashing Products comply with AAMA 711 (an FGIA Specification) *Specification for Self Adhering Flashing Used for Installation of Exterior Wall Fenestration Products*.

DuPont™ Tyvek® Fluid Applied Flashing and Joint Compound+ complies with AAMA 714, *Voluntary Specification for Liquid Applied Flashing Used to Create a Water-Resistive Seal around Exterior Wall*.

Water-Resistive Barrier (WRB) Code Requirements

The 2018 International Residential Code (Section R703.1.1 Water Resistance) requires that “the exterior wall envelope shall be designed and constructed in a manner that prevents the accumulation of water within the wall assembly by providing a water-resistant barrier behind the exterior cladding as required by Section R703.2 and a means of draining to the exterior water that penetrates the exterior cladding.” Section R703.2 (Water-resistive barrier) states that “one layer of No. 15 asphalt felt, free from holes and breaks, complying with ASTM D 226 for Type 1 felt or other approved water-resistive barrier shall be applied over studs or sheathing of all exterior walls. No. 15 asphalt felt shall be applied horizontally, with the upper layer lapped over the lower layer not less than 2 inches (51 mm). Where joints occur, felt shall be lapped not less than 6 inches (152 mm). Other approved materials shall be installed in accordance with the water-resistive barrier manufacturer’s installation instructions. The No. 15 asphalt felt or other approved water-resistive barrier shall be continuous to the top of walls and terminated at penetrations and building appendages in a manner to meet the requirements of the exterior wall envelope as described in Section R703.1.”

The 2018 International Building Code (Section 1402.2 Weather Protection) requires that “exterior walls shall provide the building with a weather-resistant exterior wall envelope. The exterior wall envelope shall be designed and constructed in such a manner as to prevent the accumulation of water within the wall assembly by providing a water-resistive barrier behind the exterior veneer, as described in Section 1403.2, and a means for draining water that enters the assembly to the exterior. The exterior wall envelope shall include flashing, as described in Section 1404.4. Section 1403.2 (Water-resistive barrier) states that “not fewer than one layer of No. 15 asphalt felt, complying with ASTM D226 for Type 1 felt or other approved materials, shall be attached to the studs or sheathing, with flashing as described in Section 1404.4 in such a manner as to provide a continuous water-resistive barrier behind the exterior veneer.”

The **DuPont™ Tyvek® WRBs** listed below qualify as approved water-resistive barriers based on ICC-ES AC38 Acceptance Criteria according to the associated Evaluation Reports:

- ICC-ES Evaluation Report ESR 2375
 - **DuPont™ Tyvek® HomeWrap®**
 - **DuPont™ Tyvek® StuccoWrap®**
 - **DuPont™ Tyvek® DrainWrap™**
 - **DuPont™ Tyvek® CommercialWrap®**
 - **DuPont™ Tyvek® CommercialWrap® D**

All **DuPont™ Tyvek® WRBs** have been tested to the following standards:

- ASTM E2556 *Type II Standard Specification for Vapor Permeable Flexible Sheet Water-Resistive Barriers Intended for Mechanical Attachment*
- ASTM E1677 *Standard Specification for an Air Retarder (AR) Material or System for Low-Rise Framed Building Walls*

- ASTM E2178 *Standard Test Method for Air Permeance of Building Materials*
- ASTM E96 *Standard Test Methods for Water Vapor Transmission of Materials*
- AATCC 127 *Test Method for Water Resistance: Hydrostatic Pressure*
- ASTM E84 *Standard Test Method for Surface Burning Characteristics of Building Materials*
- ASTM E2273 *Standard Test Method for Determining the Drainage Efficiency of Exterior Insulation and Finish Systems (EIFS) Clad Wall Assemblies* (excludes **DuPont™ Tyvek® Fluid Applied WB+™**)

The application of **DuPont™ Tyvek® WRBs** is governed by the code adopted and enforced by the local jurisdiction. Consult your jurisdiction to assure compliance with the local building code.

Additional Codes and Standards Information for DuPont™ Tyvek® Commercial Air and Water Barrier Systems

DuPont™ Tyvek® CommercialWrap®, Tyvek® CommercialWrap® D, DuPont™ StraightFlash™, DuPont™ FlexWrap™, and DuPont™ Tyvek® Fluid Applied Products were designed for the rigors of heavy commercial construction. These commercial products have been tested to the following standards:

- ABAA Evaluated
- ASTM E2357 *Standard Test Method for Determining Air Leakage of Air Barrier Assemblies*
- ASTM E331 *Standard Test Method for Water Penetration of Exterior Windows, Skylights, Doors, and Curtain Walls by Uniform Static Pressure*
- ASTM E1105 *Standard Test Method for Field Determination of Water Penetration of Installed Exterior Windows, Skylights, Door, and Curtain Walls, by Uniform or Cyclic Static Air Pressure Difference*
- ASTM E283 *Standard Test Method for Determining Rate of Air Leakage Through Exterior Windows, Curtain Walls and Doors Under Specified Pressure Differences Across the Specimen*
- AAMA 501.5 *Test Method for Thermal Cycling of Exterior Walls*
- NFPA 285 *Standard Fire Test Method for Evaluation of Fire Propagation Characteristics of Exterior Non-Load-Bearing Wall Assemblies Containing Combustible Components*

Energy Conservation Codes for commercial buildings are being adopted in many regions across the U.S. **DuPont™ Tyvek® Water-Resistive and Air Barriers (WRBs)** currently meet the following codes and guidelines.

- ASHRAE 90.1 Model Energy Code air barrier requirements
- 2018 International Energy Conservation Code® (IECC)
- 2018 International Green Construction Code® (IgCC)

General Instructions

The best time to install **Tyvek® WRBs** is:

- **AFTER** the roof sheathing is installed
- **AFTER** the step flashings and kickout flashings have been installed
- **BEFORE** the windows and doors are installed.

DuPont Self-Adhered Flashing Products and Tyvek® Fluid Applied Products are not intended for through-wall flashing applications.

Special Considerations

1. These Installation Guidelines, including the allowable use of DuPont Products, are based on building air barrier performance not exceeding ASTM E1677, and **Tyvek® WRBs** and self-adhered flashing water infiltration resistance criteria not exceeding 6.24 psf when tested in accordance with ASTM E331, ASTM E1105, or equivalent.
2. Buildings requiring NFPA 285 compliance must use **Tyvek® CommercialWrap®** or **Tyvek® CommercialWrap® D** in accordance with DuPont NFPA 285 documentation. See [NFPA 285 Compliant Wall Assemblies with DuPont™ Tyvek® Commercial Air and Water Barrier Systems](#) and building.dupont.com for more information.
3. **DuPont Self-Adhered Flashing Products** should be installed on clean, dry surfaces that are free of frost. Wipe surfaces to remove moisture, dirt, grease and other debris that could interfere with adhesion.
4. **DuPont Self-Adhered Flashing Products** perform best when installed at temperatures above 25°F (-4°C).
5. Adverse weather conditions or cold temperatures may require use of a primer to promote adhesion of **DuPont Self-Adhered Flashing Products** to most common building materials. **Concrete, masonry, and fiber-faced exterior gypsum board require the use of a recommended primer.** Do not apply the recommended primer, to exterior continuous insulation due to potential sheathing degradation.
6. Remove all wrinkles and bubbles that may allow for water intrusion by smoothing surface and repositioning as necessary during installation of **DuPont Self-Adhered Flashing Products**. Apply pressure along entire surface of flashing for a good bond using firm hand pressure, J-roller, or alternate tool without sharp edges (such as a plastic carpet tuck tool) to assist with application of uniform pressure.
7. Building envelope design requirements exceeding 0.56 psf (15 mph equivalent wind-driven rain) water infiltration resistance per ASTM E1677 require **DuPont™ StraightFlash™, DuPont™ Flashing Tape** or recommended alternate patches behind fastening plates (brick tie base plates, metal fastening clips, metal channels, etc.). When used behind the cladding fasteners and/or fastening plates, the flashing patch must be adhered to the **Tyvek® WRB**.
8. **DuPont Self-Adhered Flashing Products** are not intended for through-wall flashing applications.
9. When using mechanically fastened through-wall flashing, DuPont recommends sealing top edge with **DuPont™ Flashing Tape** or **StraightFlash™**.

10. When flashing the sill area for windows and doors, DuPont recommends the use of 6" wide **DuPont™ FlexWrap™** for 2" x 4" framing and 9" wide FlexWrap™ for 2" x 6" framing. When rigid back dams are required or desired, an option would be to use a 3/4" corner guard (back dam) cut to the length of the sill and nail into place on the interior edge of the sill prior to installation of 9" wide **FlexWrap™**. Then install 9" wide **FlexWrap™** over sill and corner guard back dam.
11. Use **DuPont Self-Adhered Flashing Products** with roll widths sufficient to achieve a minimum of 1" adhesion **BEYOND** where the back of the window or door frame will be located to allow for the creation of the interior perimeter seal.
12. **DO NOT STRETCH FlexWrap™** when installing along sills or jambs. **FlexWrap™** is only intended to be stretched when covering corners or curved sections.
13. When installing **DuPont™ FlexWrap™ EZ** and **FlexWrap™** on penetrations or other wall conditions, ensure the flashing will not be exposed after completion of cladding.
14. **DuPont Self-Adhered Flashing Products** can be used to bridge non-movement gaps up to 1" unsupported. Flashing must maintain a 2" adhesive lap on the wall substrate.
15. **DO NOT APPLY DuPont™ Tyvek® Tape** or **DuPont Self-Adhered Flashing Products** over **DuPont™ Tyvek® Wrap Cap Fasteners**, or recommended fasteners however, fasteners can be installed over the flashing.
16. When installing the **DuPont™ Tyvek® WRB**, **DO NOT INSTALL** fasteners within 6" of the sills and jambs of the openings and within 9" of the head of the openings.
17. **Great Stuff Pro™ Window and Door Polyurethane Foam Sealant** can be used in lieu of sealant to create a continuous seal around the interior perimeter of the window openings. When using **Great Stuff Pro™ Window and Door Polyurethane Foam Sealant** in perimeter openings less than 1/2", apply using the plastic extension tip for the **Great Stuff™ Dispenser Gun** during installation.
18. For additional wind load resistance, the use of **DuPont™ Flashing Tape** or **DuPont™ StraightFlash™** with **Tyvek® Wrap Cap Fasteners**, or recommended fasteners can be installed to secure the head flap of the windows.
19. **DuPont™ Tyvek® Tape** is a seam tape primarily designed to seal **Tyvek® WRB** seams. **Tyvek® Tape** is **NOT** a flashing product, and should not be used in applications where a flashing product is required.
20. Before applying **Tyvek® Tape**, surfaces should be dry and clean. During installation apply firm, even pressure with hand or "J" roller.
21. In lieu of temporarily taping, **Tyvek® WRB** flaps at window head and jambs can be tucked under the installed **Tyvek® WRB**.
22. Door and window rough sill framing must be level or slightly sloped to the exterior to ensure proper drainage to the exterior. This best practice ensures continuous support with positive slope to the exterior.
23. For window or door openings greater than 6 feet wide, **DuPont™ Flashing Tape** or **StraightFlash™** can be used with **FlexWrap™** in 3-piece sill applications. **DuPont™ Flashing Tape** or **StraightFlash™** should be applied the length of the sill prior to placing the **FlexWrap™** corners. The **FlexWrap™** corners should be at least 12" long allowing for 6" up the jamb and 6" of overlap on the **FlexWrap™** sill flashing. When applying the 3-piece flashing detail to the head of the opening, the **DuPont™ Flashing Tape** or **StraightFlash™** head piece should be applied prior to installing the **FlexWrap™** corner flashing. Minimum overlapping of the **FlexWrap™** head flashing and jamb flashing should be a minimum of 6".
24. **DuPont™ Tyvek® DrainWrap™**, **DuPont™ Tyvek® StuccoWrap®**, and **DuPont™ Tyvek® CommercialWrap® D** must be installed with the grooves going up and down.
25. **DuPont™ Tyvek® HomeWrap®** and **DuPont™ Tyvek® CommercialWrap®** provide >90% drainage efficiency, and **Tyvek® DrainWrap™**, **Tyvek® StuccoWrap®**, and **Tyvek® CommercialWrap® D** provide >98% drainage efficiency when tested in accordance with ASTM E2273.
26. No surface preparation is needed for the installation of **Tyvek® WRBs**.
27. Suitable substrates for **DuPont™ Tyvek® Fluid Applied Products** include concrete masonry unit (CMU), concrete (48 hr. cure for green concrete), exterior gypsum, OSB, plywood, wood, and metal. Contact your local DuPont Representative for use with pressure treated or fire retardant treated wood (FRT).
28. DuPont recommends the use of the **DuPont™ Tyvek® Fluid Applied Air Barrier System** for CMU walls with embedded brick ties. Please refer to the [DuPont™ Tyvek® Fluid Applied WB+™ and DuPont Flashing Products Installation Guidelines](#) for specific installation instructions.
29. **Tyvek® Fluid Applied Products** should only be used for wall systems that include a continuous path for drainage allowing moisture that penetrates the facade to exit to the exterior. The drainage path should be continuous throughout the wall assembly, including but not limited to areas such as eyebrows, band boards, penetrations, or other locations where transitions and changes of plane occur. For membrane drainage wall systems, ensure that the drainage path is not blocked or disrupted to prevent excess moisture buildup in the wall cavity.
30. When **Tyvek® Fluid Applied Products** are used as the air and water barrier, **Tyvek® WRBs** may be installed as an "intervening layer" over **Tyvek® Fluid Applied Products** after 48 hours of curing at 70°F (20°C) and 50% RH. For additional information about the use of "intervening layers" see the Stucco section under *Facade Considerations* in the applicable **Tyvek® WRB** Installation Guideline.
31. Uncured **Tyvek® Fluid Applied Products** must not come in contact with building wraps due to potential impact on performance properties.
32. **Tyvek® CommercialWrap®** and **Tyvek® CommercialWrap® D** may be installed over **Tyvek® Fluid Applied Products** after 48 hours of curing at 70°F (20°C) and 50% RH.
33. **Tyvek® HomeWrap®**, **Tyvek® StuccoWrap®**, and/or **Tyvek® DrainWrap™** should not come in direct contact with cured or uncured **Tyvek® Fluid Applied Products**.
34. **Tyvek® Fluid Applied Products** can be applied to damp surfaces. A surface is considered damp if there is no visible water on the surface and no transfer of water to the skin when touched.
35. **DuPont™ Tyvek® Fluid Applied Flashing and Joint Compound+** can be troweled or brushed to the required thickness in any application outlined in the guide.
36. **Tyvek® Fluid Applied Products** should be applied when air and surface temperatures are above 25°F. Do not install once the ambient temperature exceeds 95°F (35°C), unless the application surface is shaded. The maximum surface temperature for application is 140°F (60°C).
37. **Tyvek® Fluid Applied Products** may be overcoated once a tack-free skin has formed. Exterior insulation and/or exterior facade may be installed after **Tyvek® Fluid Applied Products** have cured for 48 hours. Please refer to *Drying/Curing* information in the [DuPont™ Tyvek® Fluid Applied WB+™ and DuPont Flashing Products Installation Guidelines](#).

38. Performance testing, included but not limited to peel adhesion, pull strength analysis, field or third-party testing of air and/or water barrier properties, should be conducted after **DuPont™ Tyvek® Fluid Applied Products** are fully cured (~14 days).
39. **DuPont™ Tyvek® WRBs** must not come in direct contact with other manufacturers' cured or uncured fluid-applied and/or deck coating waterproofing products due to potential impact on performance properties. **DuPont™ StraightFlash™** can be used as transitional membrane.
40. DuPont requires **DuPont™ Tyvek® HomeWrap®**, **DuPont™ Tyvek® StuccoWrap®**, and **DuPont™ Tyvek® DrainWrap™** be covered within 4 months (120 days) of installation. DuPont requires **DuPont™ Tyvek® CommercialWrap®** and **DuPont™ Tyvek® CommercialWrap® D** and **Tyvek® Fluid Applied Products** be covered within 9 months (270 days) of installation.
41. DuPont requires that **DuPont™ FlexWrap™**, **DuPont™ FlexWrap™ EZ**, and **StraightFlash™** be covered within 9 months (270 days) of installation. DuPont requires that **DuPont™ Flashing Tape** be covered within four months (120 days) of installation.
42. The maximum in-service temperature for **Tyvek® WRBs**, **DuPont Self-Adhered Flashing Products**, and **Tyvek® Fluid Applied Products** is 180°F.
43. Tower® Residential Sealant (formerly DuPont™ Residential Sealant) is designed for use with DuPont products and can be used where sealant is outlined in this guide. This change represents a branding change only—chemical composition and performance characteristics of the sealant are unchanged.
44. For details regarding flashing garage door openings, refer to [*Installation Instructions for Garage Doors Installed AFTER the DuPont™ Tyvek® Water-Resistive and Air Barrier \(WRB\) is Installed.*](#)
45. When applying Tower® Residential Sealant or recommended sealant during window installation, DuPont recommends minimizing or removing excess sealant that may interfere with adhesion of **DuPont Self-Adhered Flashing Products**.

For additional guidance, please call 1-833-338-7668, visit our website at building.dupont.com, or consult your local DuPont Representative.

Key Installation Requirements for Drainable Window/Door Installation

When flashing windows or doors, the following principles must be followed:

- An integral flanged window/door is defined as a window/door unit with a nailing fin or flange that is continuous around the perimeter of the window and that is a direct extrusion of the window frame.
- Any window/door that has a nailing fin or flange that is **not continuous around the perimeter** of the window/door or the fin/flange is **not a direct extrusion of the frame** (e.g. field-applied flanges) is considered a **non-integral flanged unit**.
- When installed properly, **DuPont™ StraightFlash™**, **DuPont™ FlexWrap™**, and **DuPont™ Flashing Tape** provide nail sealability at window/door openings to help protect critical window-wall interfaces. Metal sill pan flashing may be used, but must not replace flexible sill flashing that provides nail sealability.
- Ensure that sill flashing does not slope to the interior. An exterior slope is recommended, but not required.
- Direct water onto an acceptable air and water barrier drainage plane with an unobstructed path to the exterior of the wall. Provide a drainage path for any water intrusion through the window/door attachment system that collects at the sill.
- Properly integrate flashing with acceptable **DuPont™ Tyvek® WRB**. **DuPont Self-Adhered Flashing Products** must be applied with a minimum 2" lap onto the WRB.
- When applying recommended sealant during window installation, DuPont recommends minimizing or removing excess sealant that may interfere with adhesion of **DuPont Self-Adhered Flashing Products**.
- DuPont requires that **FlexWrap™**, **FlexWrap™ EZ**, and **StraightFlash™** be covered within 9 months (270 days) of installation. DuPont requires that **DuPont™ Flashing Tape** be covered within 4 months (120 days) of installation.
- Properly prepare all surfaces (remove dirt, dust, or moisture, etc.) per manufacturer's recommendations.
- Barrier installations (full perimeter seal on exterior) are acceptable only in the following instances:
 - Slab on grade doors, store front windows, or other systems with built-in drainage mechanisms that have potential for exposure to standing water
 - Surface barrier wall systems with non-water sensitive framing material (i.e., CMU walls)
 - Very low wind/rain exposure regions (southwest/desert) that follow AAMA 2400 installation guideline
- Ensure that window/door and flashing system design takes into account common factors that will impact performance, such as:
 - Climate considerations: Rainfall, Wind, Temperature (hot/cold cycles), Humidity
 - Building design: Window/Wall Design (overhangs, recessed openings, bump-outs), Wall Assembly (wood frame or masonry), Window System (wood or vinyl), New Construction or Replacement Window drainage path
 - UV exposure prior to the construction of the exterior facade
 - Compliance with fire resistance code requirements. For more information about NFPA 285 compliant wall assemblies utilizing **Tyvek® WRBs** visit building.dupont.com.
- Field testing the window/door and wall installation as a complete system is a recommended best practice.
- DuPont recommends DuPont Building Envelope Solutions Products be installed by a DuPont Certified Installer. Contact your local Building Envelope Specialist for more information about the DuPont Certified Installer program.

Sealants and Adhesives/Primers

Review the manufacturers' literature or label to confirm that the product(s) used have the chemical and adhesive properties necessary for use with **Tyvek® WRBs**, **DuPont Self-Adhered Flashing Products**, and **DuPont™ Tyvek® Fluid Applied Products**. Ensure the sealant materials meet the installation temperature requirements of the sealant manufacturer. Refer to [Chemical Compatibility of Representative Building Sealants and Adhesives/Primers](#) for more information about chemical compatibility.

Fabricating DuPont™ FlexWrap™ Recessed Window Corners



STEP 1. **Cut Four 12" Pieces of 6" FlexWrap™ Per Window.**



STEP 2. **Create Horizontal CREASE A.** Fold **FlexWrap™** at release paper to break perforations and create crease.

NOTE: The narrow release paper will be used to guide corner fold in Step 5.



STEP 3. **Create Vertical CREASE B.** Fold **FlexWrap™** in half, lengthwise, and create sharp crease at the fold.



STEP 4. **Set Corner Fold Width.** Place index finger on the top side of the **FlexWrap™** at the intersection of CREASE A and CREASE B.

NOTE: This will put pressure on the opposite side of release paper at the crease, and set the corner fold width.



STEP 5. **Create Corner Fold.** On the reverse side of the **FlexWrap™**, starting at the intersection of CREASE A and CREASE B, fold along CREASE B going out towards edge of narrow release paper.

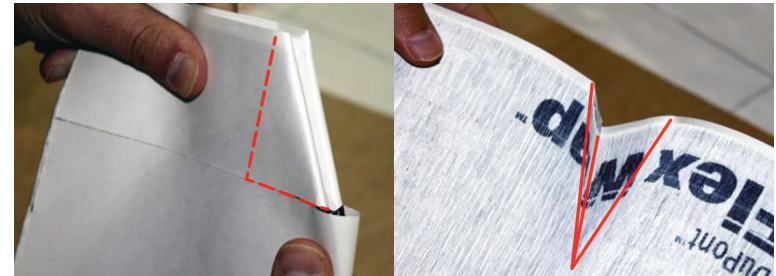

STEP 6. **Crease Center Fold.** Press firmly to create sharp crease in center and edges of fold. Sharp creases are necessary so the folds remain in the top sheet of the **FlexWrap™** after release paper is removed.

Fabricating DuPont™ FlexWrap™ Recessed Window Corners

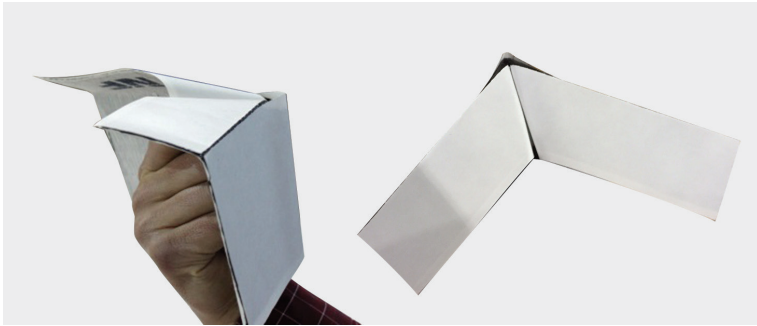

NOTE: Center crease should be sharp enough to assist in creating a ~90° fold between the two release papers at a right angle with vertical crease (Crease B), as shown below:



STEP 7. Form Recessed Window Corner. Remove narrow-width release paper and, using the creases made in Step 6, carefully press together the exposed butyl within the corner fold to create a recessed window corner. Repeat with the 3 remaining 12"–long pieces of **FlexWrap™**.

Alternative Method: Use the guide on [page 15](#) of this document to create a reusable template using a piece of hard/rigid plastic. Once created, the template can be used to aid in removal of the release paper from the corner section only as indicated below. The template will be placed over the 12"–long piece of **FlexWrap™** (release paper facing up) and aligned according to the applicable marks on the template. The release paper can then be torn along the edge of the template to expose the butyl. Alternatively, the template can be used to mark the release paper for removal. In this case a straight edge can be used to assist in tearing the release paper. **DO NOT CUT the release paper with a knife or other sharp object** as this could result in damage to the butyl and compromise protection provided by the **FlexWrap™** recessed window corners.

Once the release paper is removed to create a triangular area of expose butyl, fold the **FlexWrap™** according to [STEP 6](#) to create the 90° corner and press exposed butyl together. Once the remaining narrow release paper is removed, the recessed window corner is ready to install.

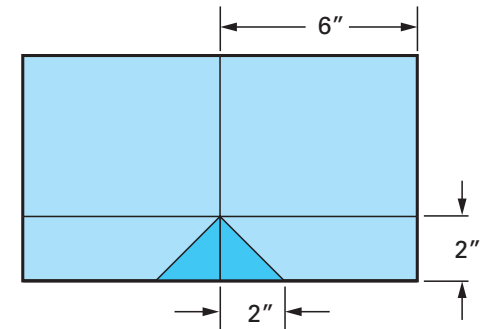

6" **FlexWrap™** (for greater than 4" recesses, single stud framing)

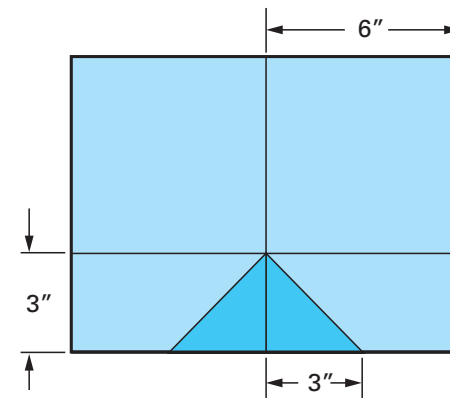

9" **FlexWrap™** (for greater than 4" recess, double stud framing)

Fabricating DuPont™ FlexWrap™ Recessed Window Corners

Corner Release Paper Removal Guide for Alternative Method Described on [Page 14](#)

When [Fabricating Recessed Window Corners](#), use the following guide to create a template to aid in removal of the release paper from the corner section only. This will assist in creating the 90° fold between the two release papers.

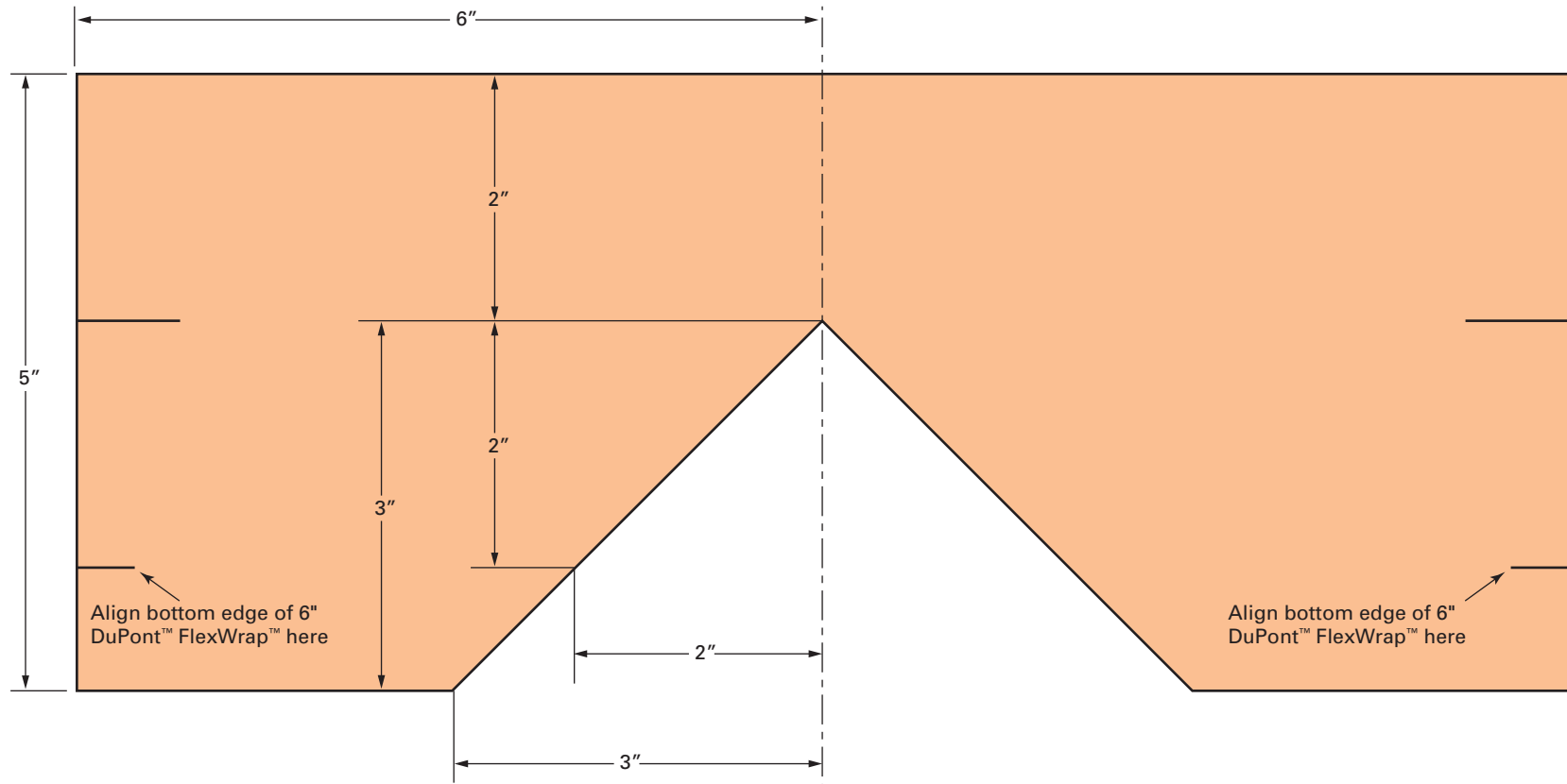

Align the bottom edge of 6" **FlexWrap™** with the the 2" marks (for up to 2" recess).
Align the bottom edge of 9" **FlexWrap™** with the lower edge of the template (for recesses greater than 2").

For best results, create a reusable template using a piece of heavy/rigid plastic. The template can also be used as a guide when tearing the release paper. Otherwise, use the template to mark the release paper and then use a metal straight edge to assist in tearing the release paper. **DO NOT CUT the release paper with a knife or other sharp object** as this could result in damage to the butyl and compromise protection provided by the **FlexWrap™** recessed window corners.

Alternate Installation Considerations

Alternate Tyvek® WRB Head Flap Preparation Method

This optional method of creating the Tyvek® WRB head flap involves trimming the flap prior to the window installation. This installation method can be used in lieu of the standard head flap preparation shown throughout this guide.

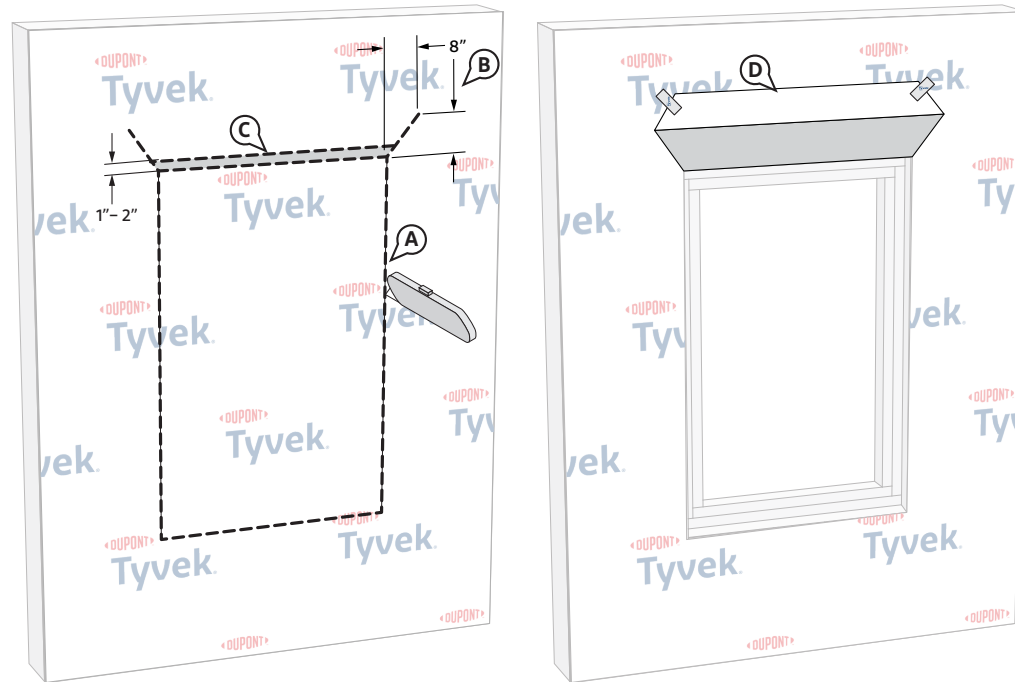

Prepare the Tyvek® WRB for Window or Door Installation

A. Make appropriate cut in the Tyvek® WRB based on the recessed window condition being addressed. Follow the steps in the applicable section within this guide.

NOTE: A shallow (up to 4") recessed window opening is shown.

B. Cut two 45 degree slits a minimum of 8" extending from the corner of the window head, up and away from the rough opening. This will create a flap above the rough opening to expose sheathing or framing members to allow head flashing installation.

NOTE: Some flashing widths may require longer slits.

C. Create another horizontal cut 1"–2" above the lower horizontal edge of the head flap.

D. Flip head flap up and temporarily secure with DuPont™ Tyvek® Tape.

ALTERNATE METHOD TO SECURE HEAD FLAP: In lieu of temporarily taping, the head flap can be tucked under the Tyvek® WRB.

Installation Methods for DuPont Self-Adhered Flashing Products Installed AFTER the DuPont™ Tyvek® WRB Integral Flanged Window with Shallow (Up to 4") Recessed Opening

Field Preparation of Recessed Window Corner Using DuPont™ FlexWrap™

The method illustrated below uses a 12"-long piece of 6" FlexWrap™ to fabricate a recessed window corner for a recess that is up to 2" deep with double stud framing. The same method can be used for recesses greater than 2" and up to 4" deep, requiring the use of a 12"-long piece of 9" FlexWrap™.

This installation guideline also applies to single stud framing, which is limited to the use of 6" FlexWrap™ for fabrication of recessed window corners. See summary of FlexWrap™ dimensions below.

Single Stud Framing

The pictures below show the 6" FlexWrap™ recessed window corner installed on a single stud window. Note that the FlexWrap™ recessed window corner extending slightly beyond the face of the stud (left) can be fully adhered into framing (right). See [STEP 2](#) for additional information.

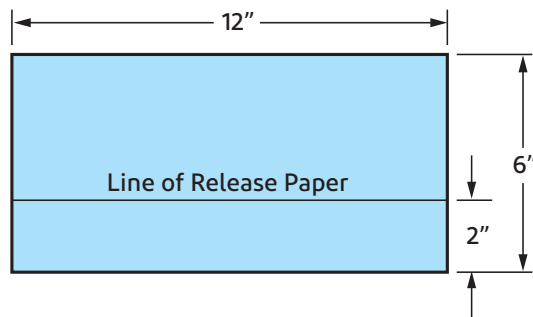
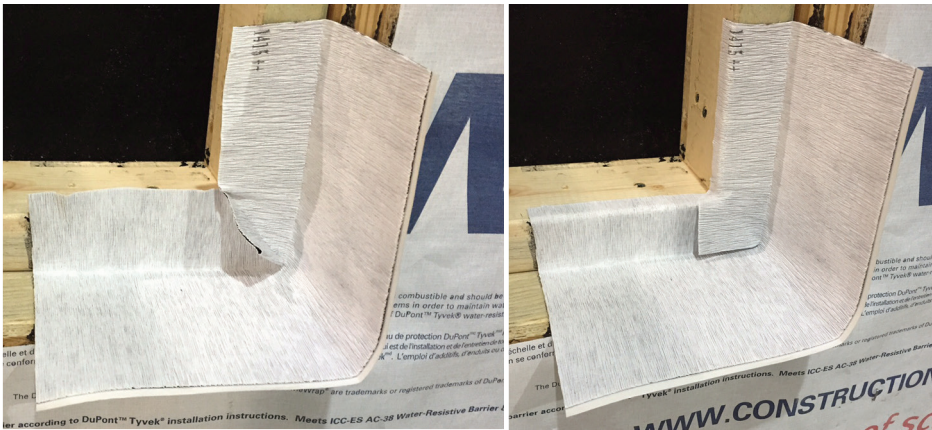

6" FlexWrap™ (for up to 2" recess, single and double stud framing)

Double Stud Framing

The following photos show the fabricated recessed window corner for a recess that is up to 2" deep with double stud window framing using 6" FlexWrap™ (left) and a recess that is 4" deep with double stud window framing using 9" FlexWrap™ (right).

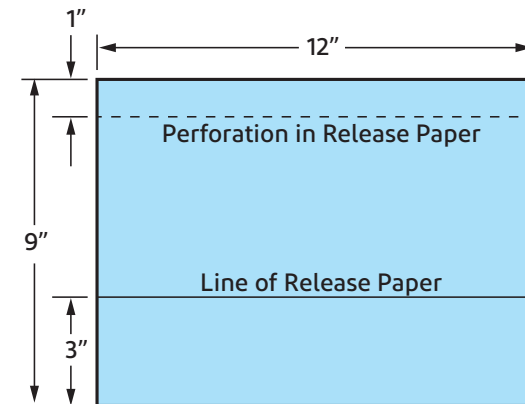

9" FlexWrap™ (for greater than 2" recess, double stud framing)

Installation Methods for DuPont Self-Adhered Flashing Products Installed AFTER the DuPont™ Tyvek® WRB Integral Flanged Window with Shallow (Up to 4") Recessed Opening

Method 1: Using DuPont™ FlexWrap™ Recessed Window Corners at the Sill

This method applies to the following products: DuPont™ Flashing Tape, DuPont™ StraightFlash™, and FlexWrap™

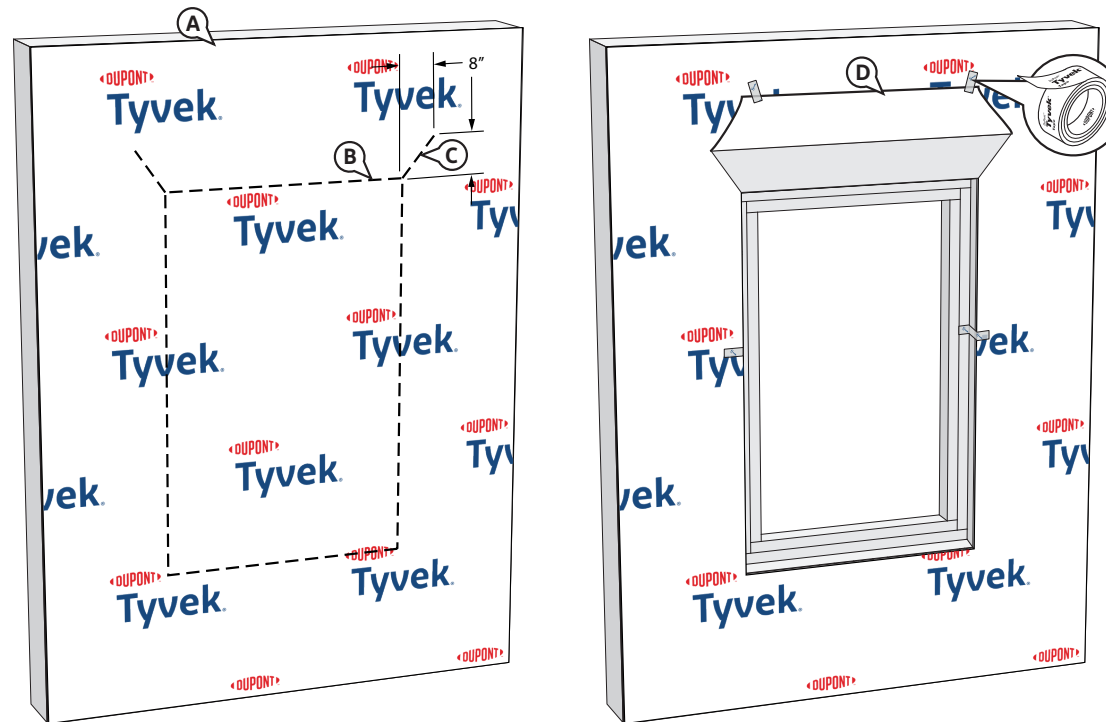

STEP 1

Prepare DuPont™ Tyvek® WRB for Window Installation

OPTIONAL: Refer to the [Alternative Installation Considerations](#) section for guidance regarding trimming the head flap while preparing the **Tyvek® WRB** if desired instead.

- Wrap wall as shown in the applicable **Tyvek® WRB** Installation Guideline that can be found at building.dupont.com. Do not install fasteners within 9" from the perimeter of the rough opening.
- Make a cut in the **Tyvek® WRB** along the perimeter of the rough opening. Ensure that the **Tyvek® WRB** is cut flush with the sheathing and is not wrapped into the rough opening.
- Cut two 45 degree slits extending a minimum of 8" from the corner of the window head, up and away from the window opening. This will create a flap above the rough opening to expose sheathing or framing members to allow head flashing installation.
- Flip head flap up and temporarily secure with **DuPont™ Tyvek® Tape**.

ALTERNATE METHOD TO SECURE HEAD FLAP: In lieu of temporarily taping, the head flap can be tucked under the **Tyvek® WRB**.

Installation Methods for DuPont Self-Adhered Flashing Products Installed AFTER the DuPont™ Tyvek® WRB

Integral Flanged Window with Shallow (Up to 4") Recessed Opening

Method 1: Using DuPont™ FlexWrap™ Recessed Window Corners at the Sill

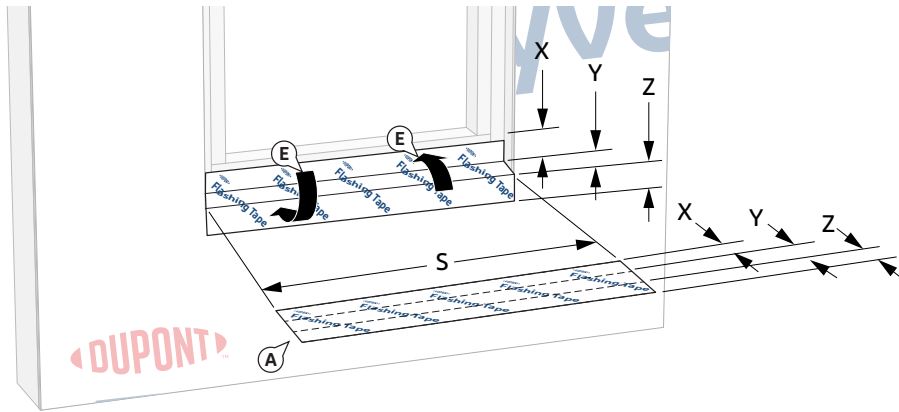

Table 1: Sill/Head Flashing for Shallow Recessed Flanged Window Condition

	X	Y	Z
6" DuPont™ Flashing Tape (single stud)	2"	1"	3"
6" DuPont™ Flashing Tape (single stud)	2"	2"	2"
6" DuPont™ Flashing Tape (double stud)	2"	2"	2"
9" DuPont™ Flashing Tape (double stud)	3"	3"	3"
9" DuPont™ Flashing Tape (double stud)	3"	4"	2"

STEP 2

Install DuPont™ Flashing Tape at Sill

- Cut the **DuPont™ Flashing Tape** the length of the outer sill (S). Refer to Table 1 above to determine which width of **DuPont™ Flashing Tape** to use.
- Fold the **DuPont™ Flashing Tape** lengthwise using the measurements (X, Y and Z) shown in Table 1, creating sharp creases to help achieve sharp corners when release paper is removed.
- Remove the center piece of release paper by carefully tearing along the creases. **DO NOT CUT** release paper with sharp object as this could result in damage to butyl and compromise protection provided by the **DuPont™ Flashing Tape**.
- Adhere exposed butyl to sill.
- Unfold unadhered flashing, remove remaining pieces of release paper and adhere butyl adhesive onto the face of the recessed window frame and onto the **DuPont™ Tyvek® WRB**.

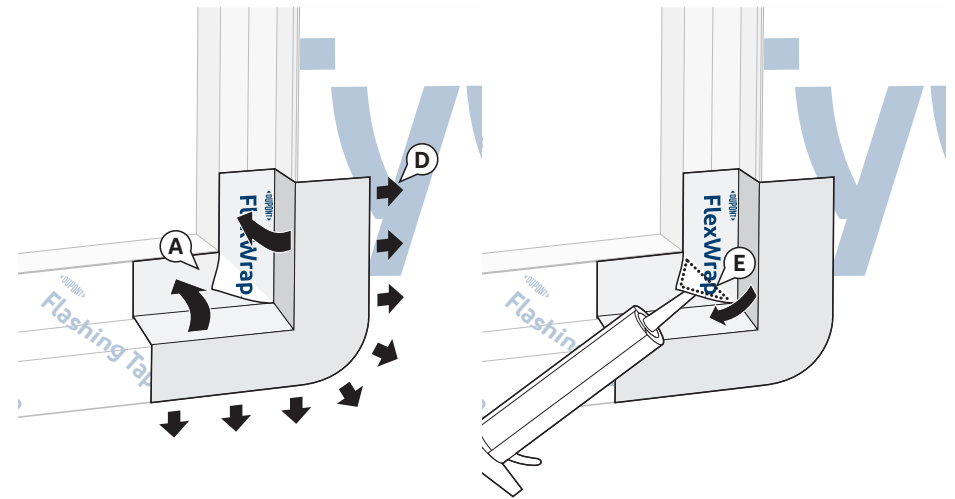

STEP 3

Install FlexWrap™ Recessed Window Corner at Sill

- Place **FlexWrap™** recessed window corner into corner of recess so exposed butyl is against face of recessed window frame and adhere.

NOTE: For double stud window frames, the **FlexWrap™** recessed window corner should extend a minimum of 2" onto the face of the recessed window frame and cover the seams between the studs. For single stud window frames, the **FlexWrap™** recessed window corner extending slightly beyond the face of the stud can be fully adhered into framing.

- Remove remaining release paper.
- Adhere exposed butyl to sill and jamb surfaces of recess.
- Fan **FlexWrap™** at bottom corners onto **Tyvek® WRB** on face of wall. Coverage of **FlexWrap™** should be 2" to 3" onto the face of the wall.
- OPTIONAL:** Apply a bead of Tower® Residential Sealant or recommended sealant inside the corner flap behind the loose triangular flap of the corner piece. Press the loose triangular flap onto the sealant in the corner piece.
- Repeat Steps A – E for opposite corner.

Installation Methods for DuPont Self-Adhered Flashing Products Installed AFTER the DuPont™ Tyvek® WRB Integral Flanged Window with Shallow (Up to 4") Recessed Opening

Method 1: Using DuPont™ FlexWrap™ Recessed Window Corners at the Sill

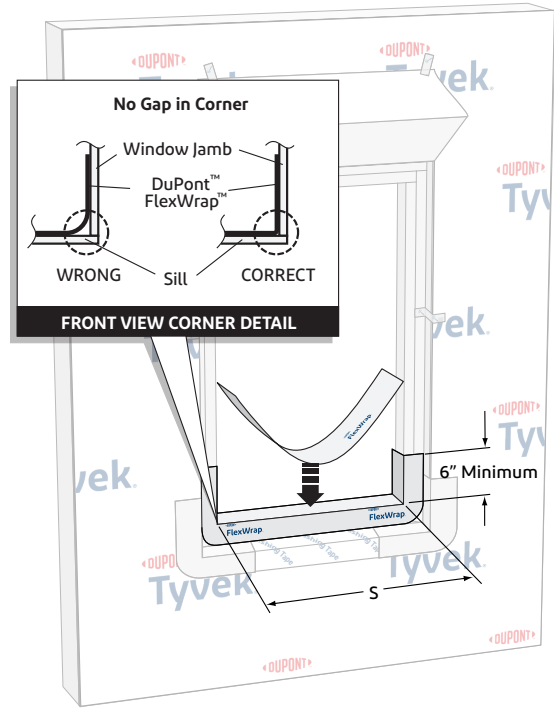

STEP 4

Install DuPont™ FlexWrap™ in Rough Opening at Sill

- Cut **FlexWrap™** at least 12" **LONGER** than width of inner/recessed sill (S). Use roll widths sufficient to achieve a minimum of 1" adhesion **BEYOND** where the window frame will be located, ensuring 2"– 3" adhesion onto the face of the framing.
- Remove wide piece of release paper. Position on horizontal surface of inner/recessed sill by aligning the inside edge of the narrow release paper with the face of the framing to ensure 2"– 3" of the **FlexWrap™** will be adhered to the face of the framing. Adhere into rough opening along sill and a minimum of 6" up each jamb.
- Remove narrow release paper.
- Fan out **FlexWrap™** at bottom corners onto face of recessed stud framing. Coverage of **FlexWrap™** should be a minimum of 2"– 3" onto the face of the recessed stud framing, extending into the recess if necessary.

Installation Methods for DuPont Self-Adhered Flashing Products Installed AFTER the DuPont™ Tyvek® WRB

Integral Flanged Window with Shallow (Up to 4") Recessed Opening

Method 1: Using DuPont™ FlexWrap™ Recessed Window Corners at the Sill

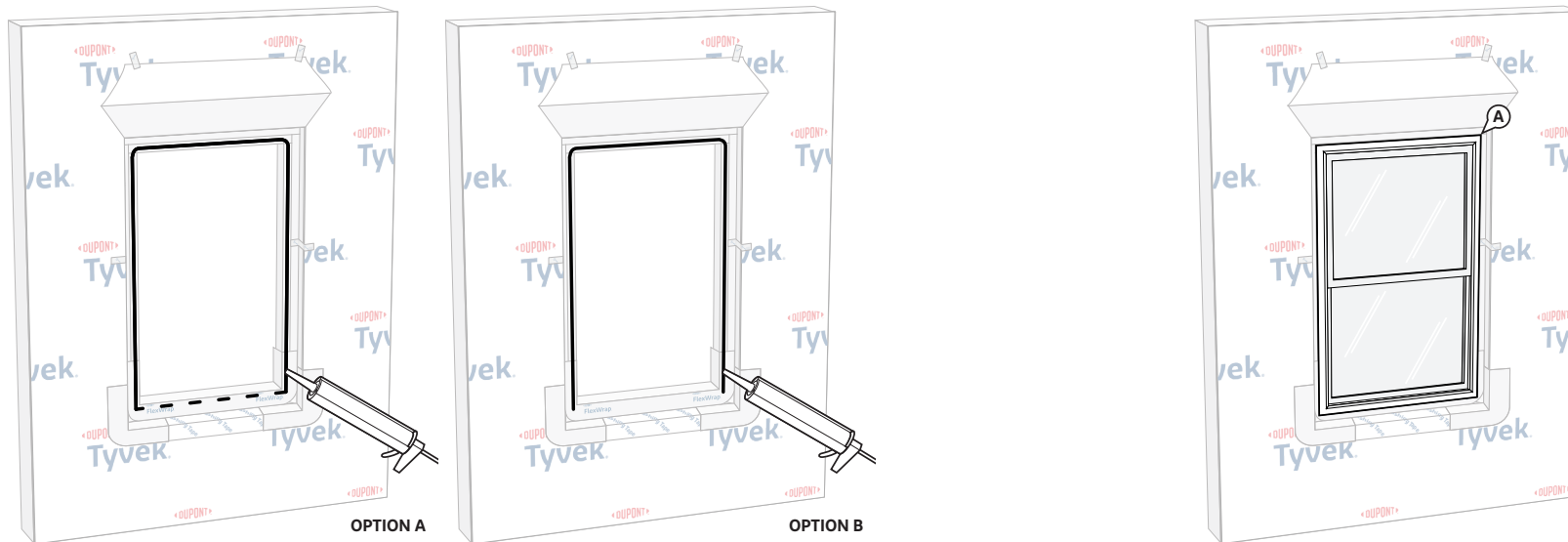

STEP 5

OPTION A: Apply a continuous bead of Tower® Residential Sealant, or recommended sealant, at window head and jambs to wall or back side of window mounting flange. To allow for drainage, do not apply continuous sealant bead along sill. Ensure a minimum 2" wide drainage gap in the sealant bead within 4" from each corner of the jamb-sill interface. Continue applying sealant along the sill with additional 2" wide (min.) drainage gaps for every 6"– 12" (on center) of sill width.

OPTION B: Apply a continuous bead of Tower® Residential Sealant, or recommended sealant, at window head and jambs to wall or back side of window mounting flange. To allow for drainage, do not apply sealant bead along sill.

STEP 6

Install Window

A. Install window per window manufacturer's instructions.

Installation Methods for DuPont Self-Adhered Flashing Products Installed AFTER the DuPont™ Tyvek® WRB

Integral Flanged Window with Shallow (Up to 4") Recessed Opening

Method 1: Using DuPont™ FlexWrap™ Recessed Window Corners at the Sill

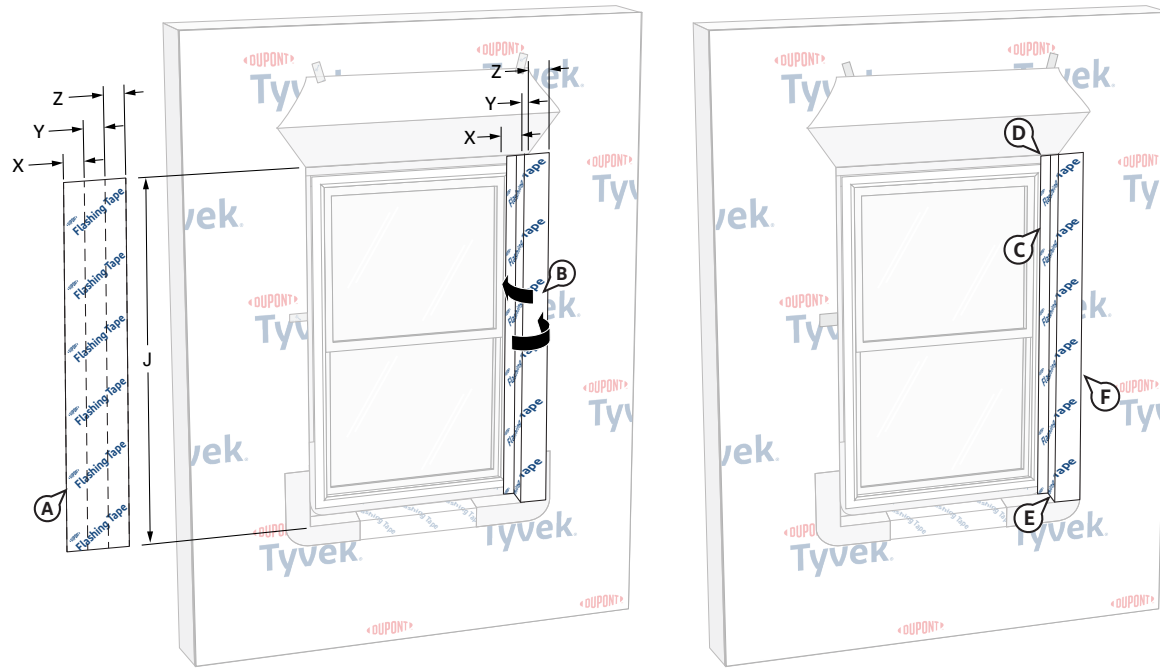

STEP 7

Install DuPont™ Flashing Tape at Jamb

A. Cut a piece of **DuPont™ Flashing Tape** the length of the outer jamb (J).

NOTE: This dimension will need to be adjusted accordingly to accommodate the slope in the sill. Use appropriate width of **DuPont™ Flashing Tape** to overlap window flange, adhere onto face of stud frame, and extend a minimum of 2" onto jamb wall of recess.

B. Fold the **DuPont™ Flashing Tape** lengthwise using the measurements (X, Y and Z) shown in Table 2 below, creating sharp creases to help achieve sharp corners when release paper is removed.

Table 2: Jamb Flashing for Shallow Recessed Flanged Window Condition

	X	Y	Z
6" DuPont™ Flashing Tape (single stud)	2"	1"	3"
6" DuPont™ Flashing Tape (single stud)	2"	2"	2"
6" DuPont™ Flashing Tape (double stud)	2"	2"	2"
9" DuPont™ Flashing Tape (double stud)	3"	3"	3"
9" DuPont™ Flashing Tape (double stud)	3"	4"	2"

C. Remove the first piece of release paper to expose the butyl that will be installed onto the window flange by tearing along the crease. **DO NOT CUT** release paper with sharp object as this could result in damage to butyl and compromise protection provided by the **DuPont™ Flashing Tape**.

NOTE: Keeping the remaining release papers intact will make the flashing more rigid to help maneuver the flashing into the corners.

D. Starting at top of window, adhere exposed butyl adhesive onto window flange.

E. Once the butyl is adhered to the window flange, remove the center release paper. The flashing can now be adhered to the inside edge of the rough opening.

F. Remove the remaining release paper and adhere the **DuPont™ Flashing Tape** onto the face of the wall and onto the **Tyvek® WRB**.

G. Repeat Steps A – F for opposite jamb.

Installation Methods for DuPont Self-Adhered Flashing Products Installed AFTER the DuPont™ Tyvek® WRB

Integral Flanged Window with Shallow (Up to 4") Recessed Opening

Method 1: Using DuPont™ FlexWrap™ Recessed Window Corners at the Sill

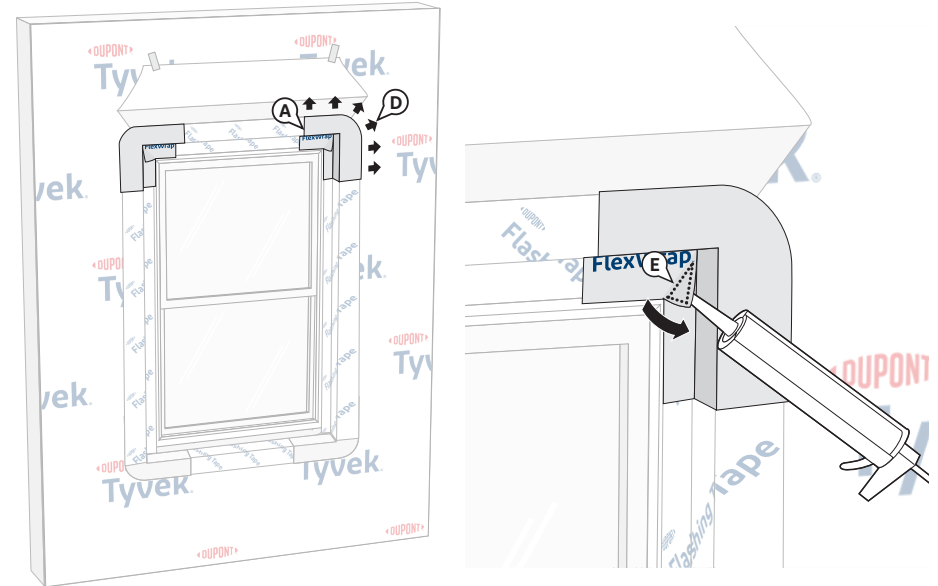
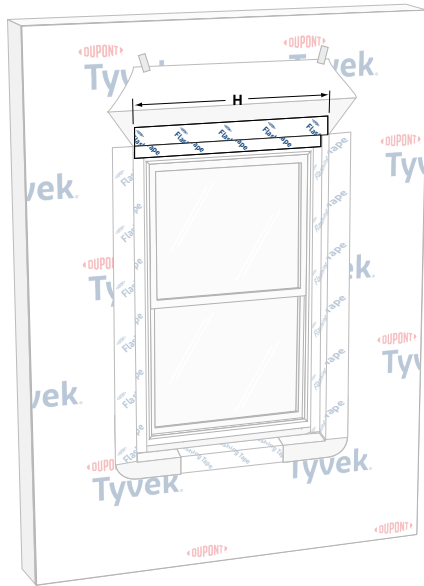

STEP 8

Install DuPont™ Flashing Tape at Head

- Cut a piece of **DuPont™ Flashing Tape** the length of the head rough opening "H".
- Fold the **DuPont™ Flashing Tape** lengthwise using the measurements (X, Y and Z) described in [STEP 3](#), creating sharp creases to help achieve sharp corners when release paper is removed.
- Remove the center release paper. The center piece of the release paper can be carefully removed by tearing along the creases, but **DO NOT CUT** release paper with sharp object as this could result in damage to butyl and compromise protection provided by the **DuPont™ Flashing Tape**.
- Adhere exposed butyl to recessed surface above window.
- Remove the outer pieces of release paper.
- Adhere exposed butyl over window head flange.
- Adhere last section of exposed butyl onto exterior sheathing.

STEP 9

Install DuPont™ FlexWrap™ Recessed Window Corners at Head

- Install **FlexWrap™** recessed window corner into the upper corner of the window rough opening with exposed butyl adhered onto the window flanges in a similar manner used for lower corner pieces ([STEP 3](#)).
- Remove remaining release paper.
- Adhere exposed butyl to head and jamb surfaces of recess.
- Fan **FlexWrap™** recessed window corner at the upper corner onto face of wall. Coverage of **FlexWrap™** recessed window corner should be 2" to 3" onto the face of the wall.
- OPTIONAL:** Apply a bead of Tower® Residential Sealant or recommended sealant inside the corner flap behind the loose triangular flap of the corner piece. Press the loose triangular flap onto the sealant in the corner piece.
- Repeat Steps A – E for opposite corner.

Installation Methods for DuPont Self-Adhered Flashing Products Installed AFTER the DuPont™ Tyvek® WRB

Integral Flanged Window with Shallow (Up to 4") Recessed Opening

Method 1: Using DuPont™ FlexWrap™ Recessed Window Corners at the Sill

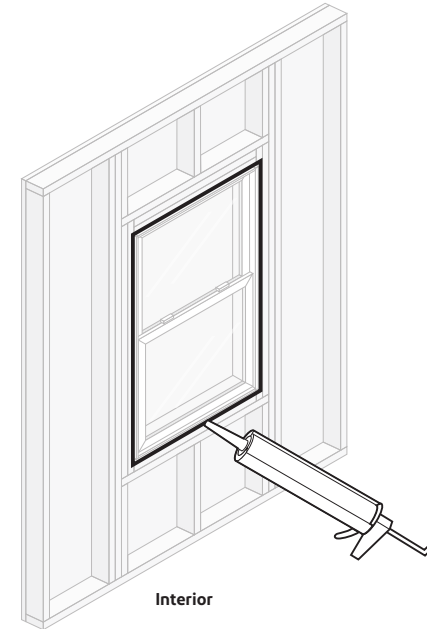
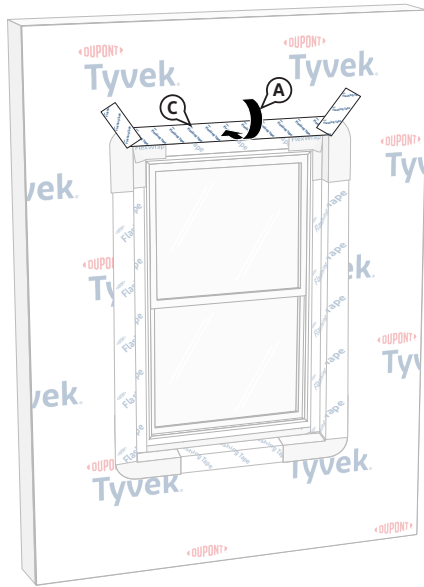

STEP 10

Secure Upper Flap

- Flip down upper flap of **DuPont™ Tyvek® WRB** so it lays flat across head flashing.
- Cut ~1" strip of the **Tyvek® WRB** at lower horizontal edge of head flap.
NOTE: Skip this step if the head flap was trimmed while preparing the **Tyvek® WRB** per the [Alternative Installation Considerations](#) section.
- Terminate head flap by continuously sealing the horizontal then diagonal seams with **DuPont™ Flashing Tape** or **DuPont™ StraightFlash™**. If additional drainage is desired and **an air barrier is not required**, skip-taping head flap with a maximum of two (2) 2" gaps for every 3' of window is acceptable.

NOTE: Install mechanical fasteners through flashing as needed for increased holding power. See the table in the [Applicable Structures and Performance Criteria](#) section for more information on air barrier requirements and head flap terminations.

STEP 11

Install Interior Perimeter Seal

Apply a continuous bead of Tower® Residential Sealant or recommended sealant (and backer rod as necessary) around the window opening at the interior. It is also acceptable to use **Great Stuff Pro™ Window & Door Polyurethane Foam Sealant**, or recommended foam. When using Tower® Residential Sealant, tool sealant bead flat to allow the natural curing process to create a concave shape. Be sure that the sealant penetrates the grooves of the **DuPont™ FlexWrap™** around the sill. When using **Great Stuff Pro™ Window & Door Polyurethane Foam Sealant** in perimeter openings less than 1/2", apply using the plastic extension tip for the **Great Stuff Pro™ Dispensing Gun** during installation.

Installation Methods for DuPont Self-Adhered Flashing Products Installed AFTER the DuPont™ Tyvek® WRB

Integral Flanged Window with Shallow (Up to 4") Recessed Opening

Method 2: Using Single Pieces of DuPont™ FlexWrap™ at the Sill and Head

This method applies to the following products: DuPont™ Flashing Tape, DuPont™ StraightFlash™, and DuPont™ FlexWrap™

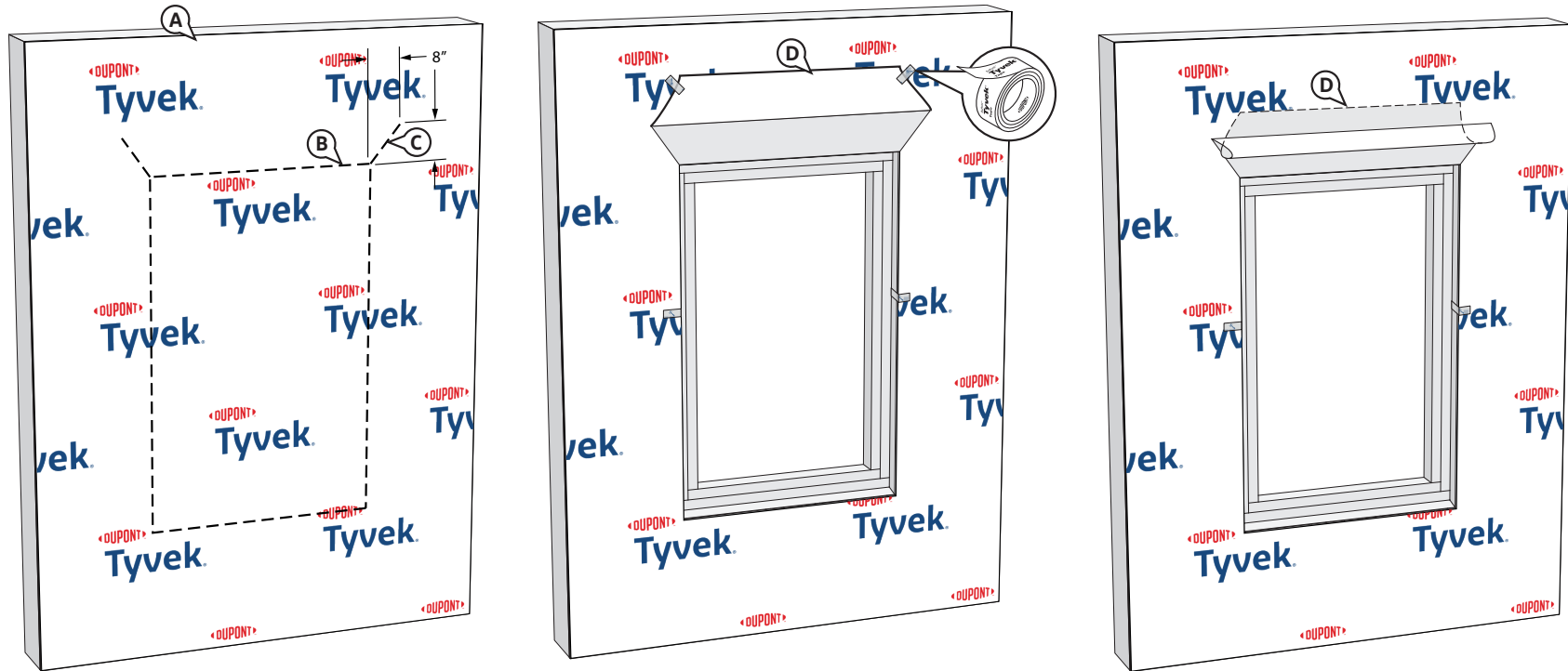

STEP 1

Prepare the Tyvek® WRB for Window Installation

OPTIONAL: Refer to the [Alternative Installation Considerations](#) section for guidance regarding trimming the head flap while preparing the Tyvek® WRB if desired instead.

- Wrap wall as shown in the applicable Tyvek® WRB Installation Guideline that can be found at building.dupont.com. Do not install fasteners within 9" from the perimeter of the rough opening.
- Make a cut in the Tyvek® WRB along the perimeter of the rough opening. Ensure that the Tyvek® WRB is cut flush with the sheathing and is not wrapped into the rough opening.
- Cut two 45 degree slits extending a minimum of 8" from the corner of the window head, up and away from the window opening. This will create a flap above the rough opening to expose sheathing or framing members to allow head flashing installation.
- Flip head flap up and temporarily secure with DuPont™ Tyvek® Tape.

ALTERNATE METHOD TO SECURE HEAD FLAP: In lieu of temporarily taping, the head flap can be tucked under the Tyvek® WRB.

Installation Methods for DuPont Self-Adhered Flashing Products Installed AFTER the DuPont™ Tyvek® WRB

Integral Flanged Window with Shallow (Up to 4") Recessed Opening

Method 2: Using Single Pieces of DuPont™ FlexWrap™ at the Sill and Head

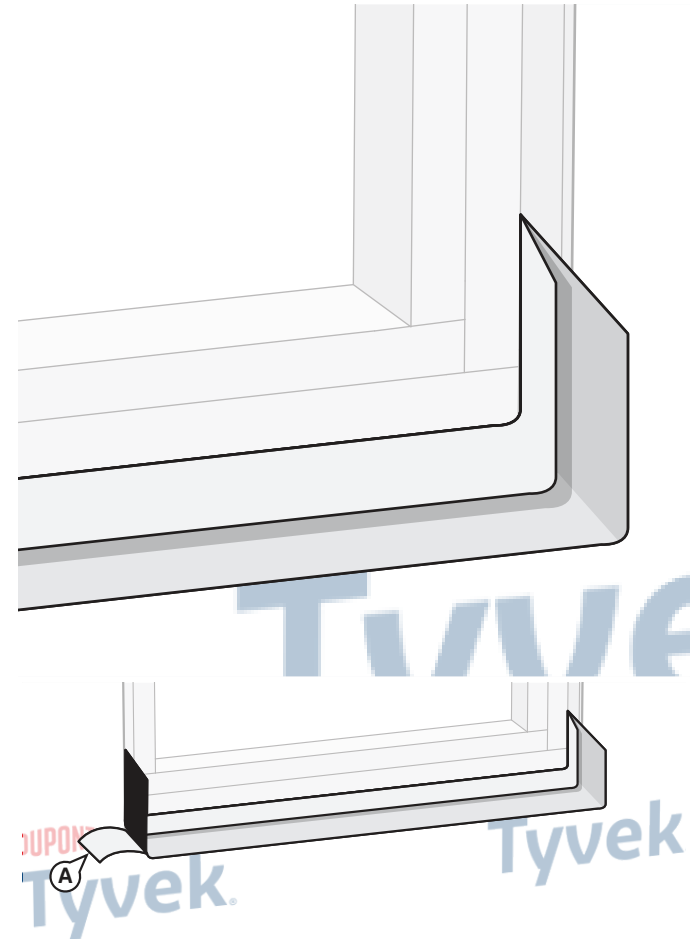
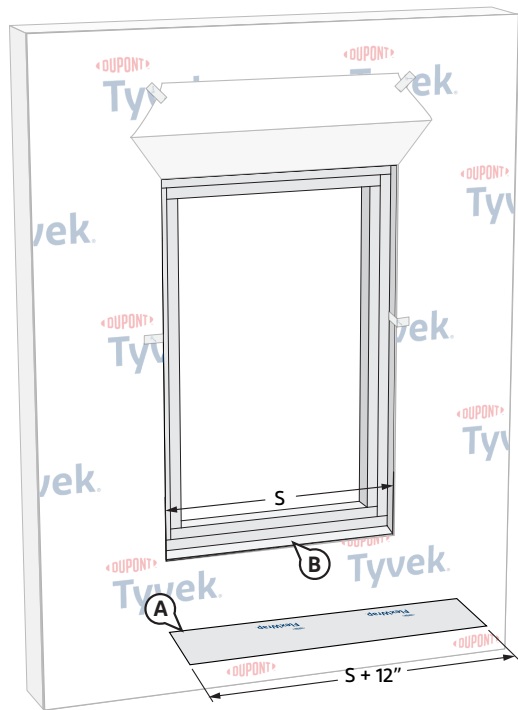

STEP 2

Prepare FlexWrap™ for Installation

- Cut **FlexWrap™** at least 12" **LONGER** than width of recessed sill (S) plane. Use roll widths sufficient to achieve adhesion to the face of stud framing, ensuring 2"– 3" adhesion onto the face of the wall.
- Inspect installation surface to ensure surface is free of dirt or substances that could interfere with adhesion as well as any sharp protrusions.

STEP 3

Install FlexWrap™ at Sill and Jamb

- Remove widest piece of release paper. Position on horizontal sill at the inside corner with a 6" minimum up each jamb. Adhere to recessed plane.

Installation Methods for DuPont Self-Adhered Flashing Products Installed AFTER the DuPont™ Tyvek® WRB

Integral Flanged Window with Shallow (Up to 4") Recessed Opening

Method 2: Using Single Pieces of DuPont™ FlexWrap™ at the Sill and Head

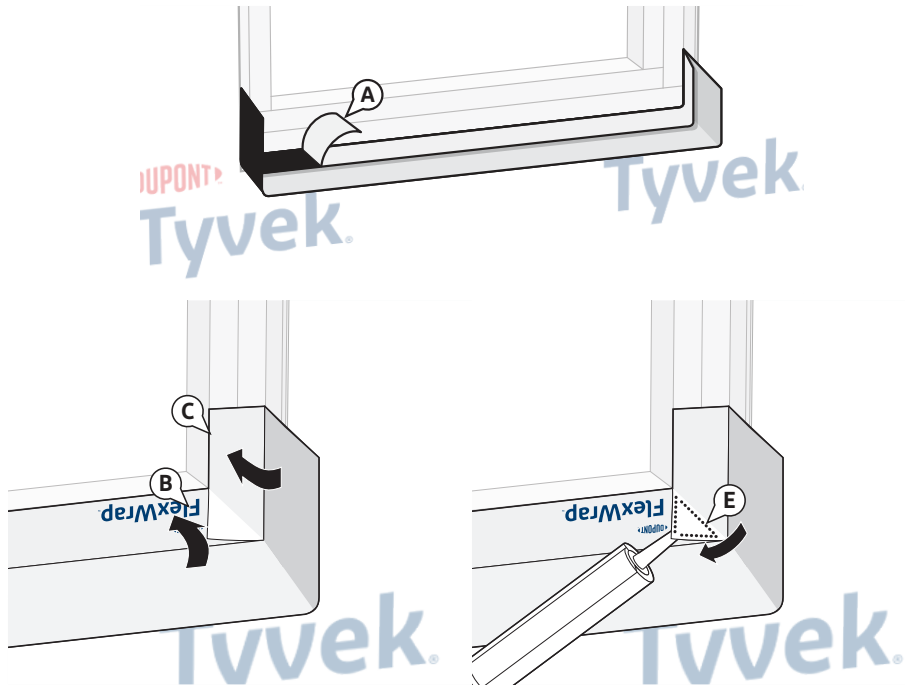

STEP 4

Install FlexWrap™ on the Face of the Rough Opening at Sill

- Remove remaining release paper and create FlexWrap™ recessed window corner.
- Adhere exposed butyl to the face of the stud framing and DuPont Self-Adhered Flashing Products. Fold the exposed butyl along the horizontal portion onto the stud framing towards sill of rough opening.
- Fold the jamb portion of the exposed butyl onto the stud framing and create a butyl-to-butyl seal, resulting in a triangular flap at the corner.
- Repeat Step C for opposite corner.
- OPTIONAL:** Apply a bead of Tower® Residential Sealant or recommended sealant inside the corner flap behind the loose triangular flap of the corner piece. Press the loose triangular onto the sealant in the corner piece.

NOTE: For double stud window frames, the FlexWrap™ recessed window corners should extend a minimum of 3" onto the face of the recessed window frame and cover the seams between the studs. For single stud window frames, the FlexWrap™ recessed window corner should extend and cover face of the stud framing.

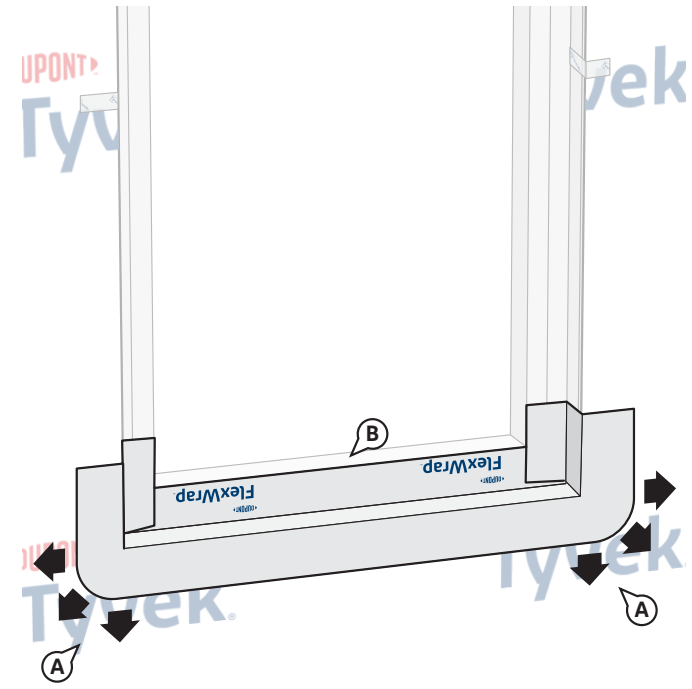

STEP 5

Install FlexWrap™ on Face of Wall

- Fan out the FlexWrap™ at corners and adhere onto Tyvek® WRB. Continue adhering onto face of wall along sill. Coverage of FlexWrap™ should be 2"– 3" onto the face of the wall.
- Firmly press sill flashing to ensure full adhesion on all surfaces. Eliminate wrinkles and bubbles by smoothing surface and repositioning as necessary.

Installation Methods for DuPont Self-Adhered Flashing Products Installed AFTER the DuPont™ Tyvek® WRB Integral Flanged Window with Shallow (Up to 4") Recessed Opening

Method 2: Using Single Pieces of DuPont™ FlexWrap™ at the Sill and Head

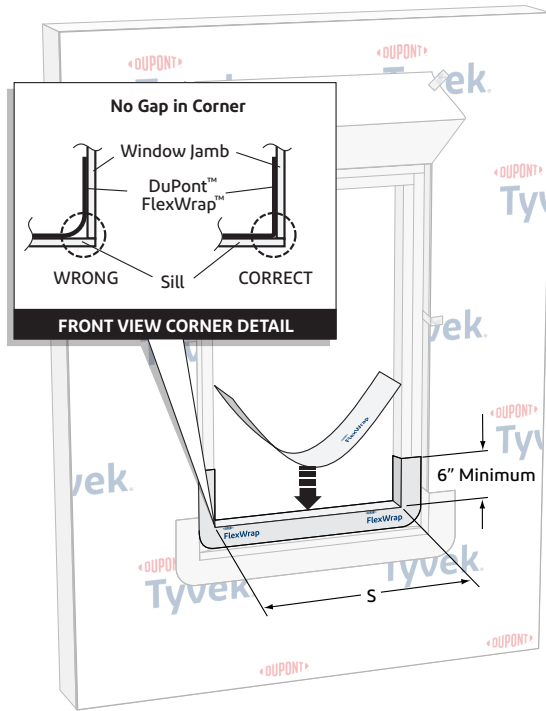

STEP 6

Install FlexWrap™ in Rough Opening at Sill

- Cut **FlexWrap™** at least 12" **LONGER** than width of inner/recessed sill (S). Use roll widths sufficient to achieve a minimum of 1" adhesion **BEYOND** where the window frame will be located, ensuring 2"– 3" adhesion onto the face of the framing.
- Remove wide piece of release paper. Position on horizontal surface of inner/recessed sill by aligning the inside edge of the narrow release paper with the face of the framing to ensure 2"– 3" of the **FlexWrap™** will be adhered to the face of the framing. Adhere into rough opening along sill and a minimum of 6" up each jamb.
- Remove narrow release paper.
- Fan out **FlexWrap™** at bottom corners onto face of recessed stud framing. Coverage of **FlexWrap™** should be a minimum of 2"– 3" onto the face of the recessed stud framing, extending into the recess if necessary.

Installation Methods for DuPont Self-Adhered Flashing Products Installed AFTER the DuPont™ Tyvek® WRB

Integral Flanged Window with Shallow (Up to 4") Recessed Opening

Method 2: Using Single Pieces of DuPont™ FlexWrap™ at the Sill and Head

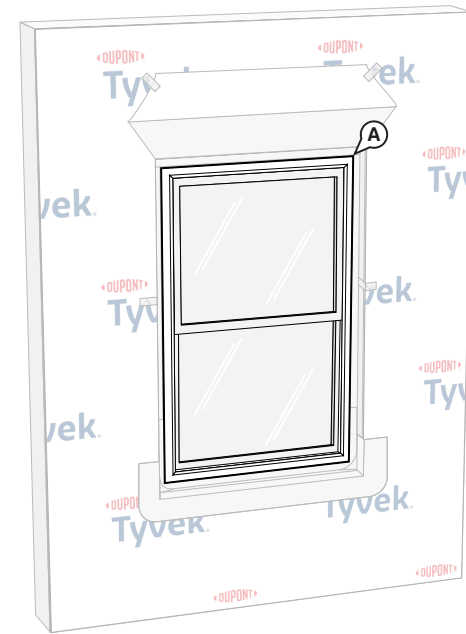
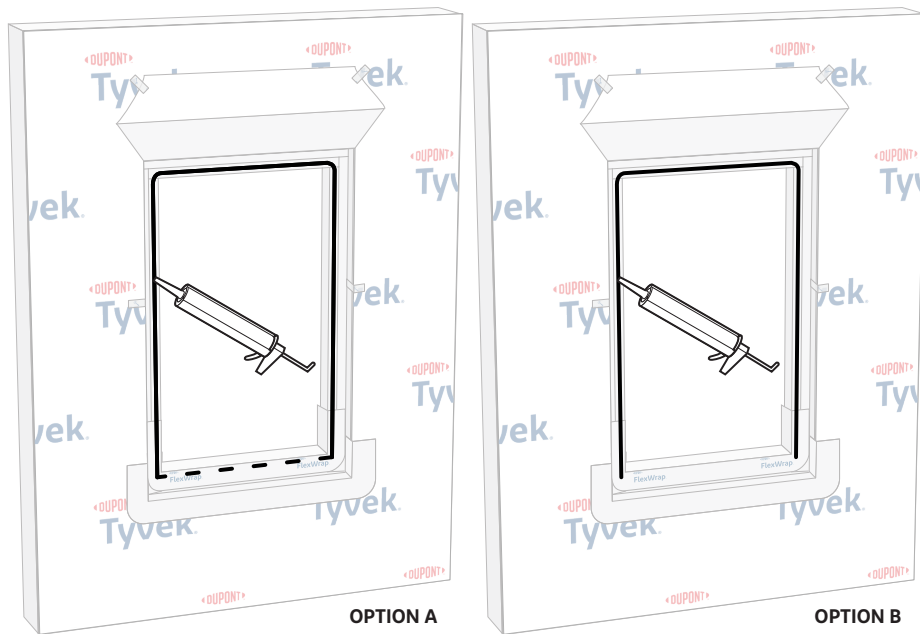

STEP 7

OPTION A: Apply a continuous bead of Tower® Residential Sealant, or recommended sealant, at window head and jambs to wall or back side of window mounting flange. To allow for drainage, do not apply continuous sealant bead along sill. Ensure a minimum 2" wide drainage gap in the sealant bead within 4" from each corner of the jamb-sill interface. Continue applying sealant along the sill with additional 2" wide (min.) drainage gaps for every 6"– 12" (on center) of sill width.

OPTION B: Apply a continuous bead of Tower® Residential Sealant, or recommended sealant, at window head and jambs to wall or back side of window mounting flange. To allow for drainage, do not apply sealant bead along sill.

STEP 8

Install Window

A. Install integral flanged window per manufacturer's instructions

Installation Methods for DuPont Self-Adhered Flashing Products Installed AFTER the DuPont™ Tyvek® WRB Integral Flanged Window with Shallow (Up to 4") Recessed Opening

Method 2: Using Single Pieces of DuPont™ FlexWrap™ at the Sill and Head

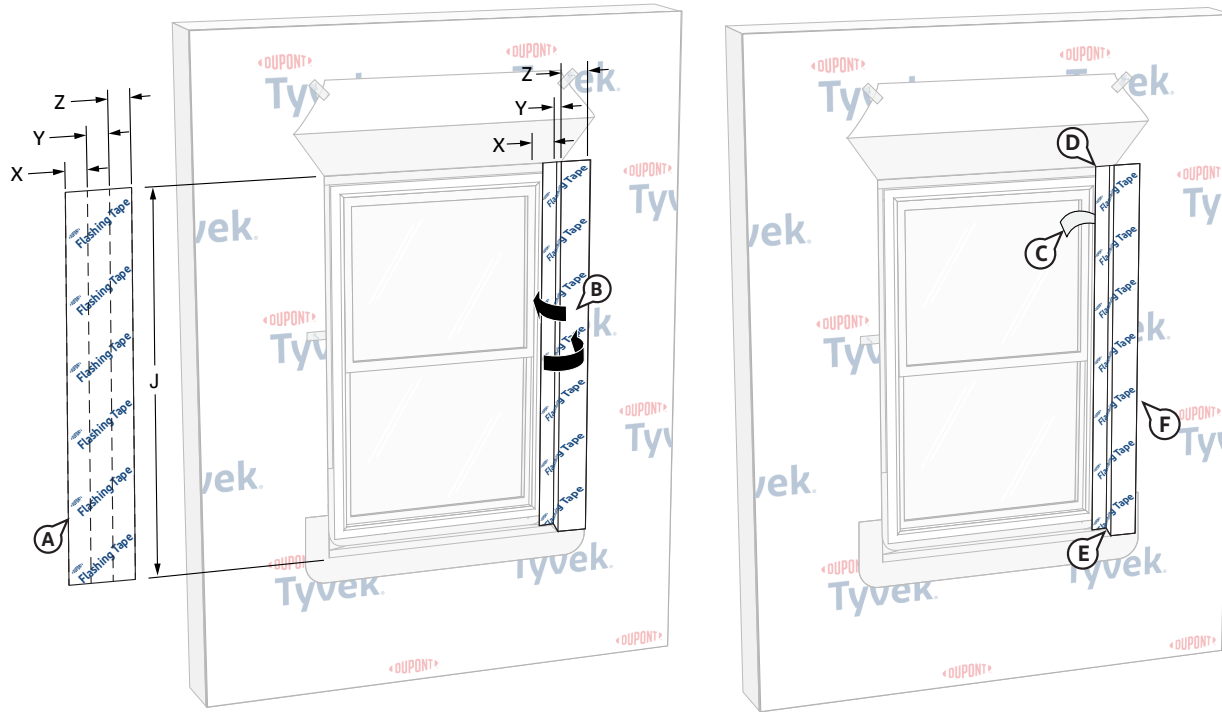

STEP 9

Install* DuPont™ Flashing Tape at Jamb

- A. Cut a piece of **DuPont™ Flashing Tape** or **DuPont™ StraightFlash™** that is the length of the outer jamb (J).
- B. Fold the **DuPont™ Flashing Tape** or **StraightFlash™** lengthwise using the measurements (X, Y and Z) shown in Table 1 below, creating sharp creases to help achieve sharp corners when release paper is removed.

Table 1: Jamb Flashing for Shallow Recessed Flanged Window Condition

	X	Y	Z
6" DuPont™ Flashing Tape (single stud)	2"	1"	3"
6" DuPont™ Flashing Tape (single stud)	2"	2"	2"
6" DuPont™ Flashing Tape (double stud)	2"	2"	2"
9" DuPont™ Flashing Tape (double stud)	3"	3"	3"
9" DuPont™ Flashing Tape (double stud)	3"	4"	2"

- C. Remove release liner.
- D. Position and install window jamb flashing.
- E. Roll flashing into the corner and along the recessed plane
- F. Extend remaining flashing to face of wall. Coverage of **DuPont™ Flashing Tape** should be 2"– 3" onto the face of the wall.
- G. Firmly press sill flashing to ensure full adhesion on all surfaces. Eliminate wrinkles and bubbles by smoothing surface and repositioning as necessary.

Installation Methods for DuPont Self-Adhered Flashing Products Installed AFTER the DuPont™ Tyvek® WRB

Integral Flanged Window with Shallow (Up to 4") Recessed Opening

Method 2: Using Single Pieces of DuPont™ FlexWrap™ at the Sill and Head

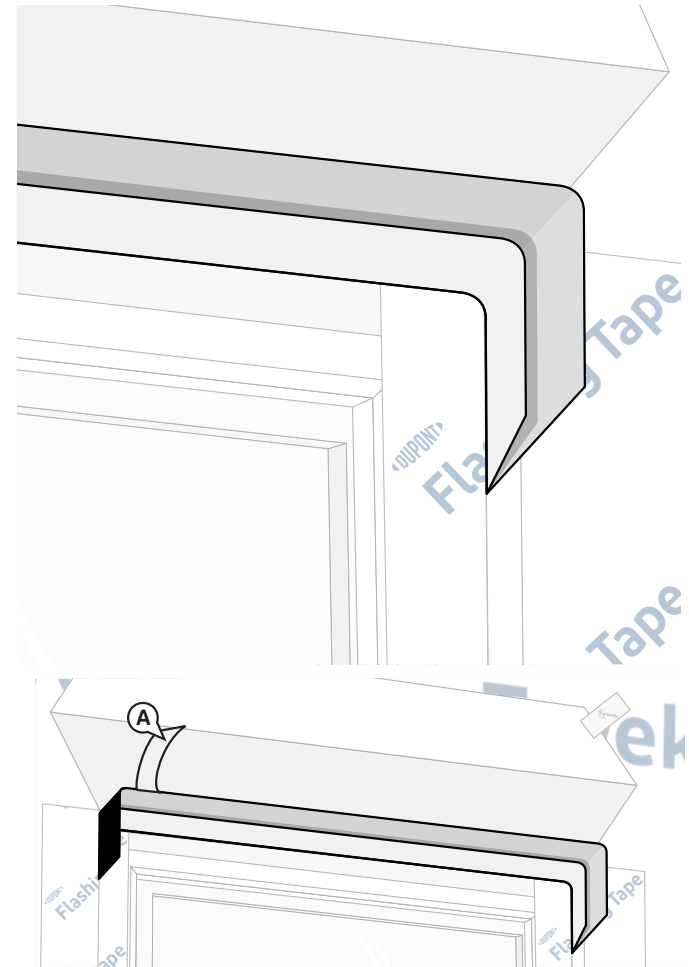
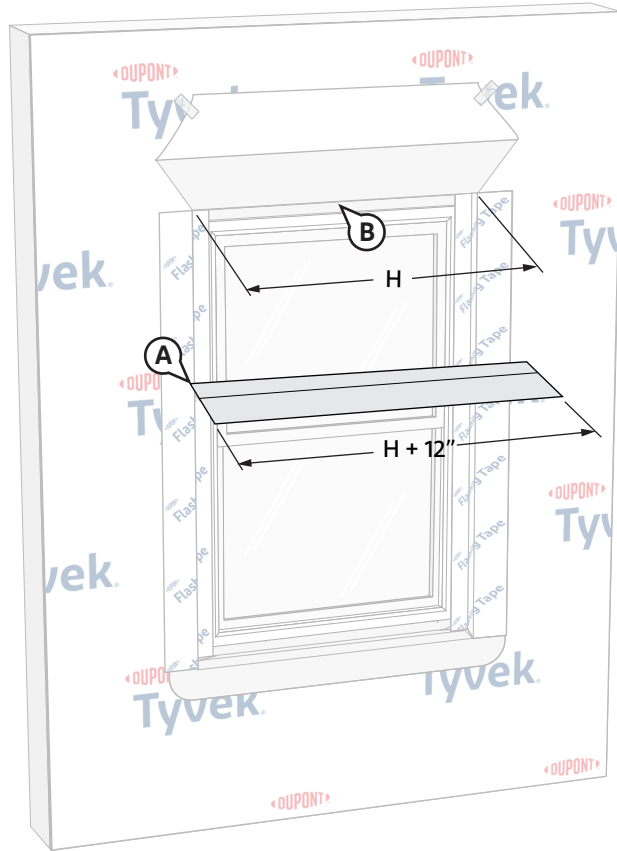

STEP 10

Prepare FlexWrap™ for Installation

- Cut **FlexWrap™** at least 12" **LONGER** than width of recessed head (H) plane. Use roll widths sufficient to achieve adhesion to the face of stud framing, ensuring 2"– 3" adhesion onto the face of the wall.
- Inspect installation surface to ensure surface is free of dirt or substances that could interfere with adhesion as well as any sharp protrusions.

STEP 11

Install FlexWrap™ at Head and Jamb

- Remove widest piece of release paper. Position on horizontal head at the inside corner with a 6" minimum down each jamb. Adhere to recessed plane.

Installation Methods for DuPont Self-Adhered Flashing Products Installed AFTER the DuPont™ Tyvek® WRB

Integral Flanged Window with Shallow (Up to 4") Recessed Opening

Method 2: Using Single Pieces of DuPont™ FlexWrap™ at the Sill and Head

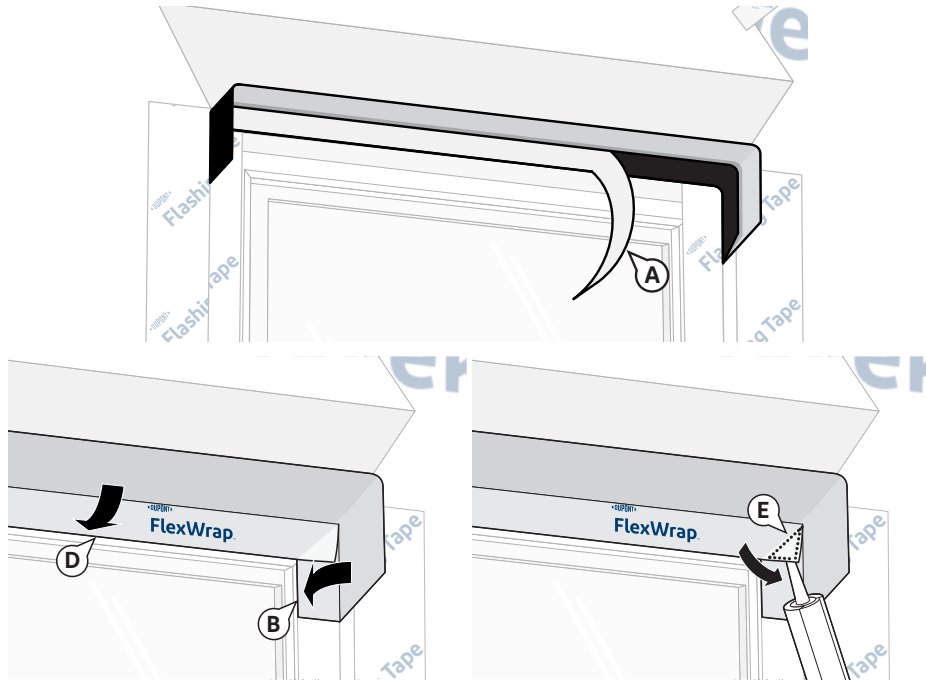

STEP 12

Install FlexWrap™ on the Face of the Rough Opening at Head

- Remove remaining release paper and create **FlexWrap™** recessed window corner.
- Adhere exposed butyl to the face of the stud framing and **DuPont Self-Adhered Flashing Products**. Fold the exposed butyl along the jamb portion onto the stud framing.
- Fold the exposed butyl along the head portion onto the stud framing and create a butyl-to-butyl seal, resulting in a triangular flap at the corner.
- Repeat Step C for opposite corner.
- OPTIONAL:** Apply a bead of Tower® Residential Sealant or recommended sealant inside the corner flap behind the loose triangular flap of the corner piece. Press the loose triangular onto the sealant in the corner piece.

NOTE: For double stud window frames, the **FlexWrap™** recessed window corners should extend a minimum of 3" onto the face of the recessed window frame and cover the seams between the studs. For single stud window frames, the **FlexWrap™** recessed window corner should extend and cover face of the stud framing.

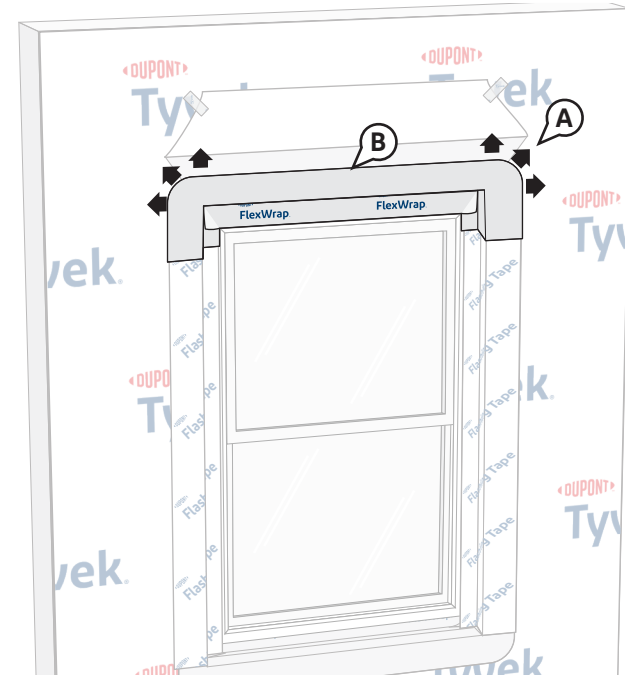

STEP 13

Install FlexWrap™ at Window Head

- Fan out the **FlexWrap™** at corners and adhere onto **Tyvek® WRB**. Continue adhering onto face of wall along sill. Coverage of **FlexWrap™** should be 2"–3" onto the face of the wall.
- Firmly press sill flashing to ensure full adhesion on all surfaces. Eliminate wrinkles and bubbles by smoothing surface and repositioning as necessary.

NOTE: For exterior gypsum sheathing, apply a recommended adhesive/primer to the exposed sheathing. An adhesive/primer is not required for wood-based sheathing, except when applying flashing during adverse weather conditions.

Installation Methods for DuPont Self-Adhered Flashing Products Installed AFTER the DuPont™ Tyvek® WRB Integral Flanged Window with Shallow (Up to 4") Recessed Opening

Method 2: Using Single Pieces of DuPont™ FlexWrap™ at the Sill and Head

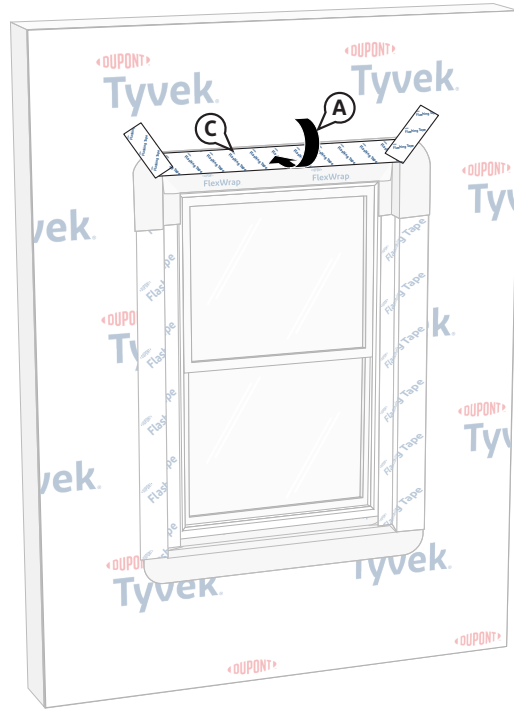

more information on air barrier requirements and head flap terminations.

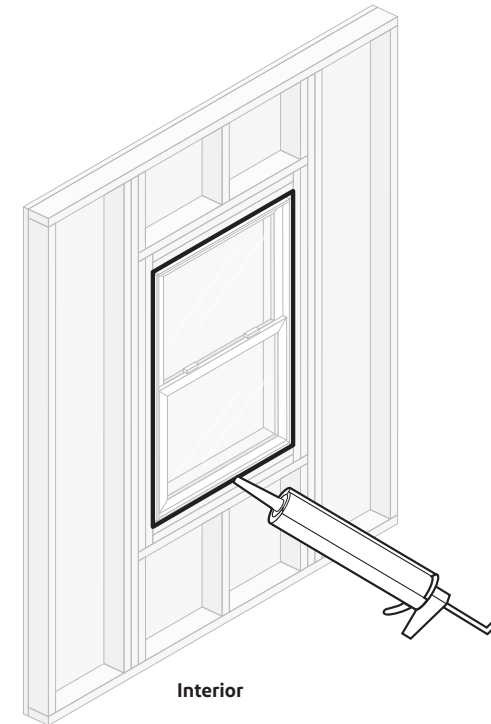

STEP 14

Secure Upper Flap

- Flip down upper flap of **Tyvek® WRB** so it lays flat across head flashing.
- Cut ~1" strip of the **Tyvek® WRB** at lower horizontal edge of head flap.

NOTE: Skip this step if the head flap was trimmed while preparing the **Tyvek® WRB** per the [Alternative Installation Considerations](#) section.

- Terminate head flap by continuously sealing the horizontal then diagonal seams with **DuPont™ Flashing Tape** or **DuPont™ StraightFlash™**. If additional drainage is desired and **an air barrier is not required**, skip-taping head flap with a maximum of two (2) 2" gaps for every 3' of window is acceptable.

NOTE: Install mechanical fasteners through flashing as needed for increased holding power. See the table in the [Applicable Structures and Performance Criteria](#) section for

STEP 15

Install Interior Perimeter Seal

Apply a continuous bead of Tower® Residential Sealant or recommended sealant (and backer rod as necessary) around the window opening at the interior. It is also acceptable to use **Great Stuff Pro™ Window & Door Polyurethane Foam Sealant**, or recommended foam. When using Tower® Residential Sealant, tool sealant bead flat to allow the natural curing process to create a concave shape. Be sure that the sealant penetrates the grooves of the **DuPont™ FlexWrap™** around the sill. When using **Great Stuff Pro™ Window & Door Polyurethane Foam Sealant** in perimeter openings less than 1/2", apply using the plastic extension tip for the **Great Stuff Pro™ Dispensing Gun** during installation.

Hybrid Installation Methods for DuPont Self-Adhered Flashing Products and DuPont™ Tyvek® Fluid Applied Products Installed AFTER the DuPont™ Tyvek® WRB

Integral Flanged Window with Shallow (Up to 4”) Recessed Opening

Method 1: Using “Wrap the Cavity” Method along Edge of Rough Opening with DuPont Self-Adhered Flashing Products and DuPont™ Tyvek® Fluid Applied Flashing and Joint Compound+
This method applies to the following products: DuPont™ StraightFlash™, DuPont™ FlexWrap™, and DuPont™ Tyvek® Fluid Applied Flashing and Joint Compound+

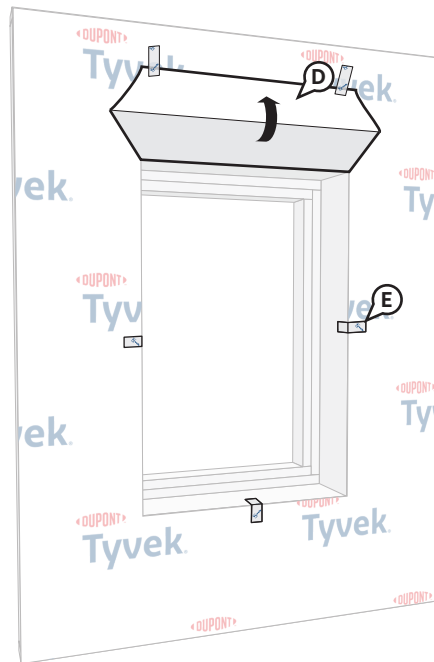
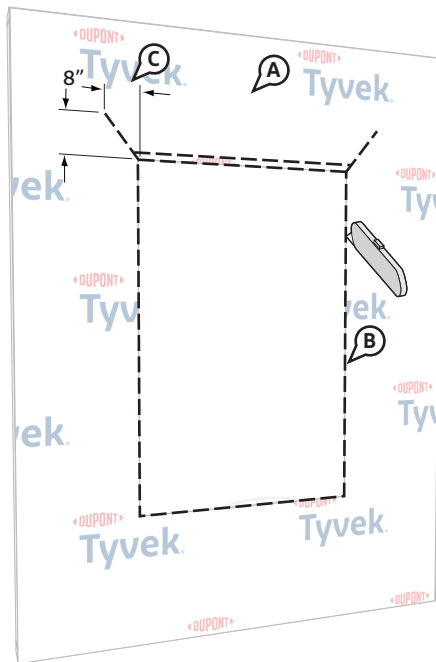

Alternate Method to Secure Head Flap

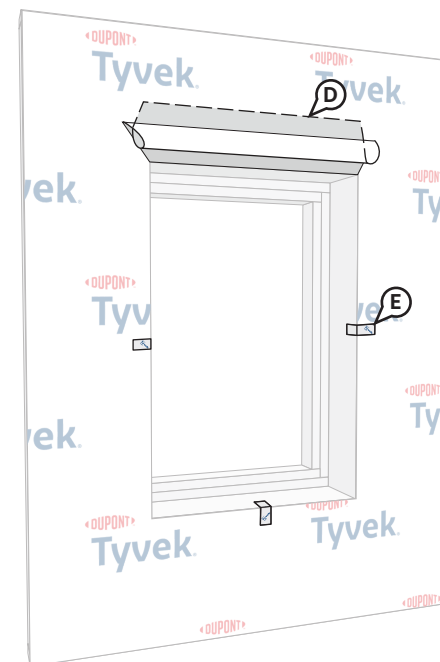

STEP 1

Prepare Tyvek® WRB Frame for Window Installation

OPTIONAL: Refer to the [Alternative Installation Considerations](#) section for guidance regarding trimming the head flap while preparing the Tyvek® WRB if desired instead.

- A. Wrap wall as shown in the applicable Tyvek® WRB Installation Guideline that can be found at building.dupont.com. Do not install fasteners within 6” of the sill and jambs of the openings and within 9” of the head of the openings.
- B. Make a cut in the Tyvek® WRB along the perimeter of the rough opening. Ensure that the Tyvek® WRB is cut flush with the sheathing and is not wrapped into the rough opening.
- C. Cut two 45 degree slits extending a minimum of 8” up and away from the top corners of the rough opening. This will create a flap to expose sheathing or framing members to allow head flashing installation.

- D. Flip the head flap up to expose the sheathing and temporarily secure with DuPont™ Tyvek® Tape.

Alternative Method to Secure Head Flap: In lieu of temporarily taping, the head flap can be tucked under the Tyvek® WRB.

- E. Temporarily secure the Tyvek® WRB frame with Tyvek® Tape around rough opening before flashing is installed to help facilitate flashing installation.

Hybrid Installation Methods for DuPont Self-Adhered Flashing Products and DuPont™ Tyvek® Fluid Applied Products Installed AFTER the DuPont™ Tyvek® WRB

Integral Flanged Window with Shallow (Up to 4") Recessed Opening

Method 1: Using "Wrap the Cavity" Method along Edge of Rough Opening with DuPont Self-Adhered Flashing Products and DuPont™ Tyvek® Fluid Applied Flashing and Joint Compound+

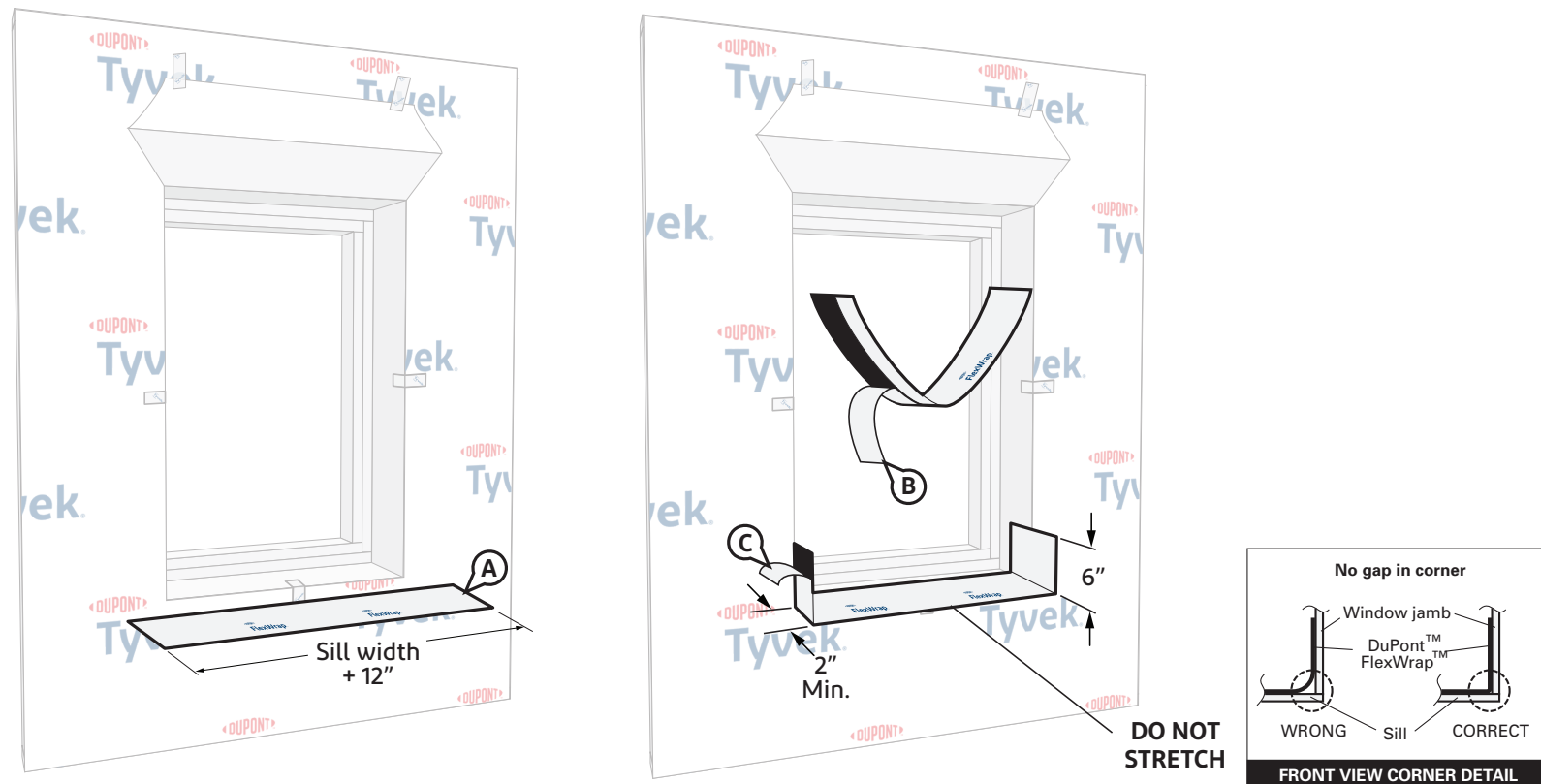

STEP 2

Install* DuPont™ FlexWrap™ at Outer Sill of Recessed Opening

A. Prepare the sill flashing by cutting a piece of **FlexWrap™** that is at least 12" **LONGER** than outer sill width.

B. Remove wide piece of release paper. Position on outer horizontal sill by aligning the inside edge of the narrow release paper with the face of the wall to ensure 2"–3" of the **FlexWrap™** will be adhered to the face of the wall with a minimum of 6" up each jamb. Adhere into rough opening.

C. Remove narrow release paper.

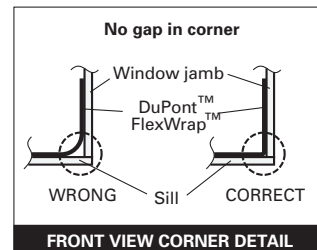

*Use **DuPont Self-Adhered Flashing Products** with a recommended adhesive/primer as applicable to seal directly to exterior gypsum sheathing, concrete, masonry, or other rough surfaces. An adhesive/primer is not required for wood-based sheathing except when applying flashing during adverse weather conditions.

Hybrid Installation Methods for DuPont Self-Adhered Flashing Products and DuPont™ Tyvek® Fluid Applied Products Installed AFTER the DuPont™ Tyvek® WRB

Integral Flanged Window with Shallow (Up to 4") Recessed Opening

Method 1: Using "Wrap the Cavity" Method along Edge of Rough Opening with DuPont Self-Adhered Flashing Products and DuPont™ Tyvek® Fluid Applied Flashing and Joint Compound+

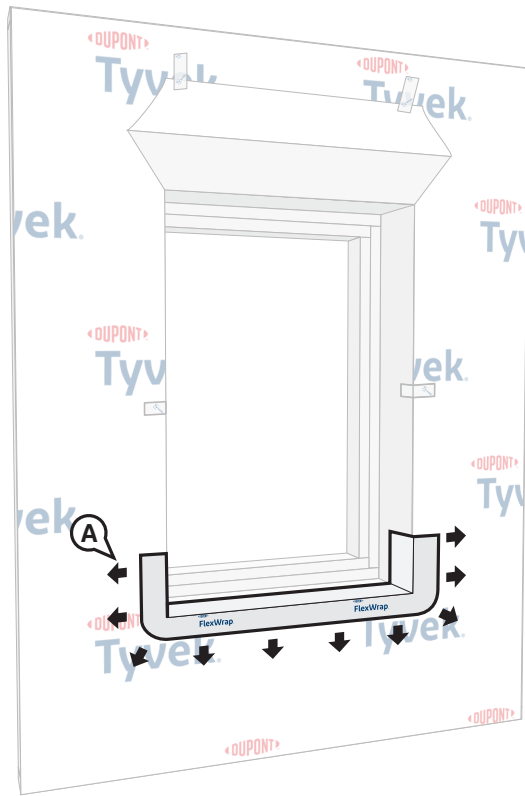

STEP 3

- Fan out the **DuPont™ FlexWrap™** at corners and adhere onto face of wall. Continue adhering onto face of wall along sill.
- Firmly press sill flashing to ensure full adhesion on all surfaces. Eliminate wrinkles and bubbles by smoothing surface.

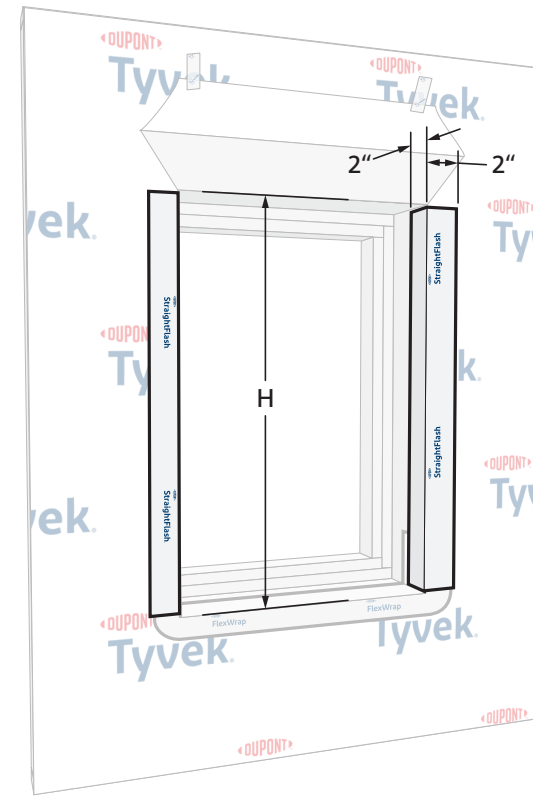

STEP 4

Install* DuPont™ StraightFlash™ at Jambs

- Cut two pieces of **StraightFlash™** the height of the outer rough opening (H).
- Adhere **StraightFlash™** into the recessed rough opening at each jamb and onto wall face. The flashing should extend a minimum of 2" onto both surfaces.

*Use **DuPont Self-Adhered Flashing Products** with a recommended adhesive/primer as applicable to seal directly to exterior gypsum sheathing, concrete, masonry, or other rough surfaces. An adhesive/primer is not required for wood-based sheathing except when applying flashing during adverse weather conditions.

Hybrid Installation Methods for DuPont Self-Adhered Flashing Products and DuPont™ Tyvek® Fluid Applied Products Installed AFTER the DuPont™ Tyvek® WRB

Integral Flanged Window with Shallow (Up to 4") Recessed Opening

Method 1: Using "Wrap the Cavity" Method along Edge of Rough Opening with DuPont Self-Adhered Flashing Products and DuPont™ Tyvek® Fluid Applied Flashing and Joint Compound*

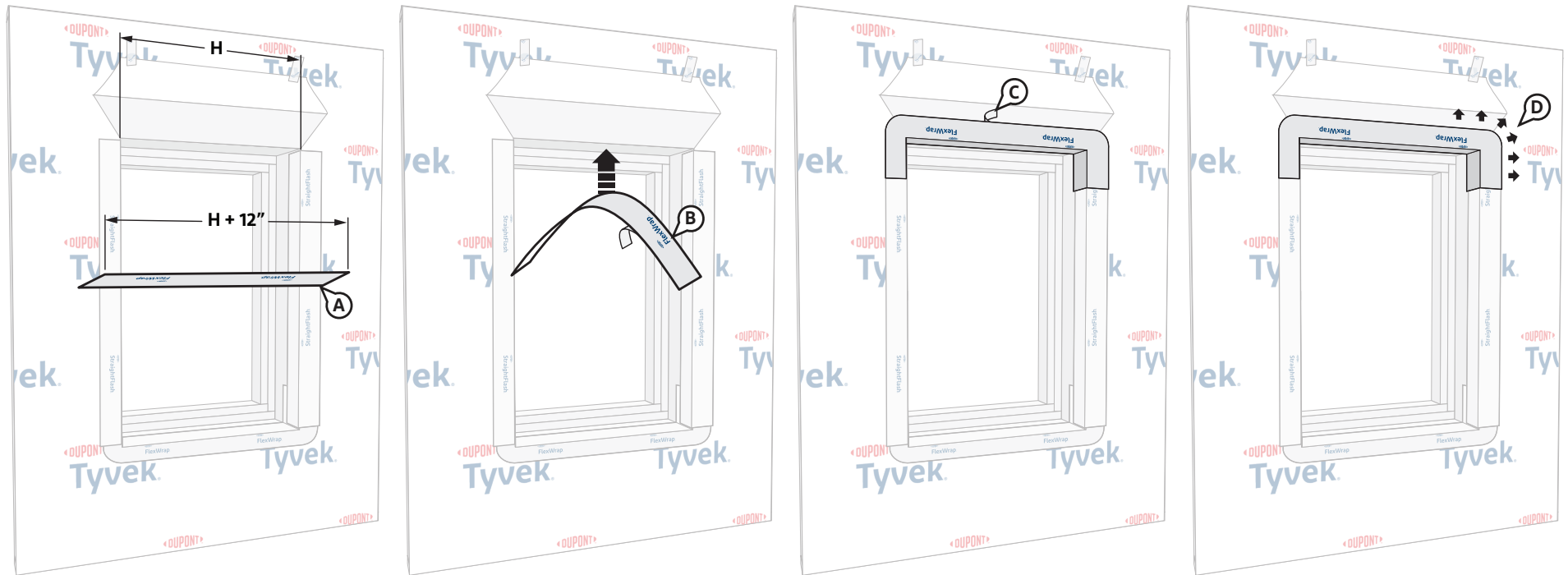

STEP 5

Install* DuPont™ FlexWrap™ Head of Outer Recess

- Cut **FlexWrap™** at least 12" **LONGER** than width of rough opening head (H). Use roll widths sufficient to achieve a minimum of 1" adhesion **BEYOND** where the window frame will be located, ensuring 2"- 3" adhesion onto the face of the wall.
- Fold the **FlexWrap™** in half lengthwise to create a slight crease at the center. Remove the wide piece of release paper on one side of the fold. Align the inside edge of the narrow release paper with the face of the wall to ensure 2"- 3" of the **FlexWrap™** will be adhered to the face of the wall. Starting at the crease, adhere the **FlexWrap™** at the center of the horizontal portion of the head framing to ensure a minimum of 6" down each jamb. Adhere into rough opening at one corner and down the jamb. Remove the remaining release paper, and repeat at opposite corner.
- Remove narrow release paper.
- Fan out the **FlexWrap™** at corners and adhere onto face of wall. Continue adhering onto face of wall along the head.

*Use **DuPont Self-Adhered Flashing Products** with a recommended adhesive/primer as applicable to seal directly to exterior gypsum sheathing, concrete, masonry, or other rough surfaces. An adhesive/primer is not required for wood-based sheathing except when applying flashing during adverse weather conditions.

Hybrid Installation Methods for DuPont Self-Adhered Flashing Products and DuPont™ Tyvek® Fluid Applied Products Installed AFTER the DuPont™ Tyvek® WRB

Integral Flanged Window with Shallow (Up to 4”) Recessed Opening

Method 1: Using “Wrap the Cavity” Method along Edge of Rough Opening with DuPont Self-Adhered Flashing Products and DuPont™ Tyvek® Fluid Applied Flashing and Joint Compound+

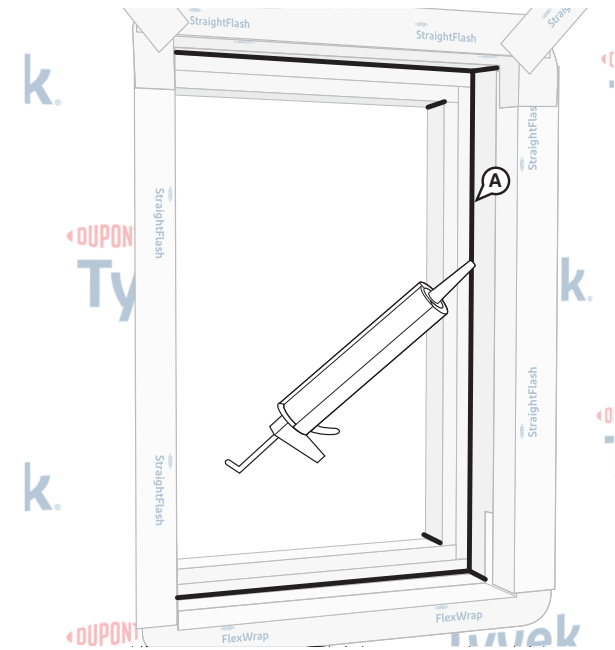
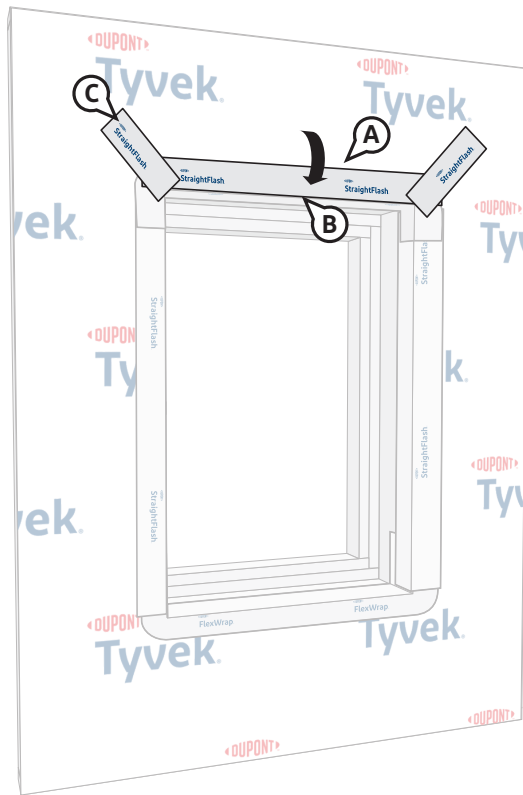

STEP 6

Secure Upper Flap

- Flip down the upper flap of the **DuPont™ Tyvek® WRB** so it lays flat across head flashing.
- Cut 1”– 2” strip of the **Tyvek® WRB** at lower horizontal edge of the head flap.
NOTE: Skip this step if the head flap was trimmed while preparing the **Tyvek® WRB** per the [Alternative Installation Considerations](#) section.
- Terminate head flap as shown by continuously sealing the horizontal and then the diagonal seams with **DuPont™ StraightFlash™** or **DuPont™ Flashing Tape**.

NOTE: For a more robust head flap termination, seal with **DuPont™ Flashing Tape** or **StraightFlash™**. Install mechanical fasteners through flashing as needed for increased holding power. See the table in the [Applicable Structures and Performance Criteria](#) section for more information on air barrier requirements and head flap terminations.

STEP 7

Prepare Rough Opening

After the outside portion of the recessed opening has been integrated with the **Tyvek® WRB** using **DuPont™ FlexWrap™** and **StraightFlash™**, coat the remaining rough opening using **DuPont™ Tyvek® Fluid Applied Flashing and Joint Compound+** according to STEPS 7 and 8.

- Pretreat all inside corners, nail holes and small gaps by applying a bead of **Tyvek® Fluid Applied Flashing and Joint Compound+** or recommended sealant to the surface. If gaps in framing are over 1/4” wide, apply self-adhered fiberglass mesh tape over the gap or into corner before applying sealant. Primer may be needed to promote adhesion of the mesh tape.

Hybrid Installation Methods for DuPont Self-Adhered Flashing Products and DuPont™ Tyvek® Fluid Applied Products Installed AFTER the DuPont™ Tyvek® WRB

Integral Flanged Window with Shallow (Up to 4”) Recessed Opening

Method 1: Using “Wrap the Cavity” Method along Edge of Rough Opening with DuPont Self-Adhered Flashing Products and DuPont™ Tyvek® Fluid Applied Flashing and Joint Compound+

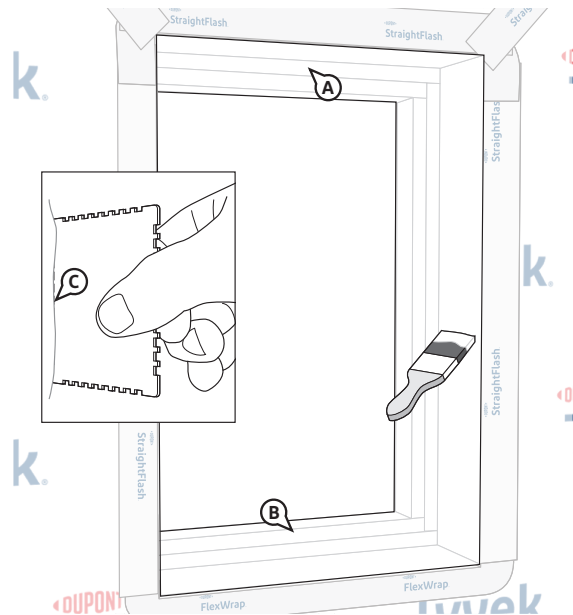

STEP 8

Apply Tyvek® Fluid Applied Flashing and Joint Compound+

After the **Tyvek® Fluid Applied Flashing and Joint Compound+** or recommend sealant pretreatment has skinned over, begin applying **Tyvek® Fluid Applied Flashing and Joint Compound+**. DuPont recommends using a stiff disposable brush or trowel to apply.

- Begin applying **Tyvek® Fluid Applied Flashing and Joint Compound+** at the head of the opening and work down to the jambs and then sill.
- Continue to apply the **Tyvek® Fluid Applied Flashing and Joint Compound+** over the entire inside portion of the rough opening, overlapping the **DuPont™ FlexWrap™** and **DuPont™ StraightFlash™** up to the outer edge of the rough opening at the face of the wall. Be sure to work the **Tyvek® Fluid Applied Flashing and Joint Compound+** into any small cracks, holes, and edges of the **FlexWrap™** and **StraightFlash™**.
- Tyvek® Fluid Applied Flashing and Joint Compound+** should be applied at 25 mils thick. Use a wet mil thickness gauge to check application thickness. Upon completion, inspect surface to ensure that **Tyvek® Fluid Applied Flashing and Joint Compound+** is continuous and **free of any voids or pinholes**.

Hybrid Installation Methods for DuPont Self-Adhered Flashing Products and DuPont™ Tyvek® Fluid Applied Products Installed AFTER the DuPont™ Tyvek® WRB

Integral Flanged Window with Shallow (Up to 4") Recessed Opening

Method 1: Using "Wrap the Cavity" Method along Edge of Rough Opening with DuPont Self-Adhered Flashing Products and DuPont™ Tyvek® Fluid Applied Flashing and Joint Compound+

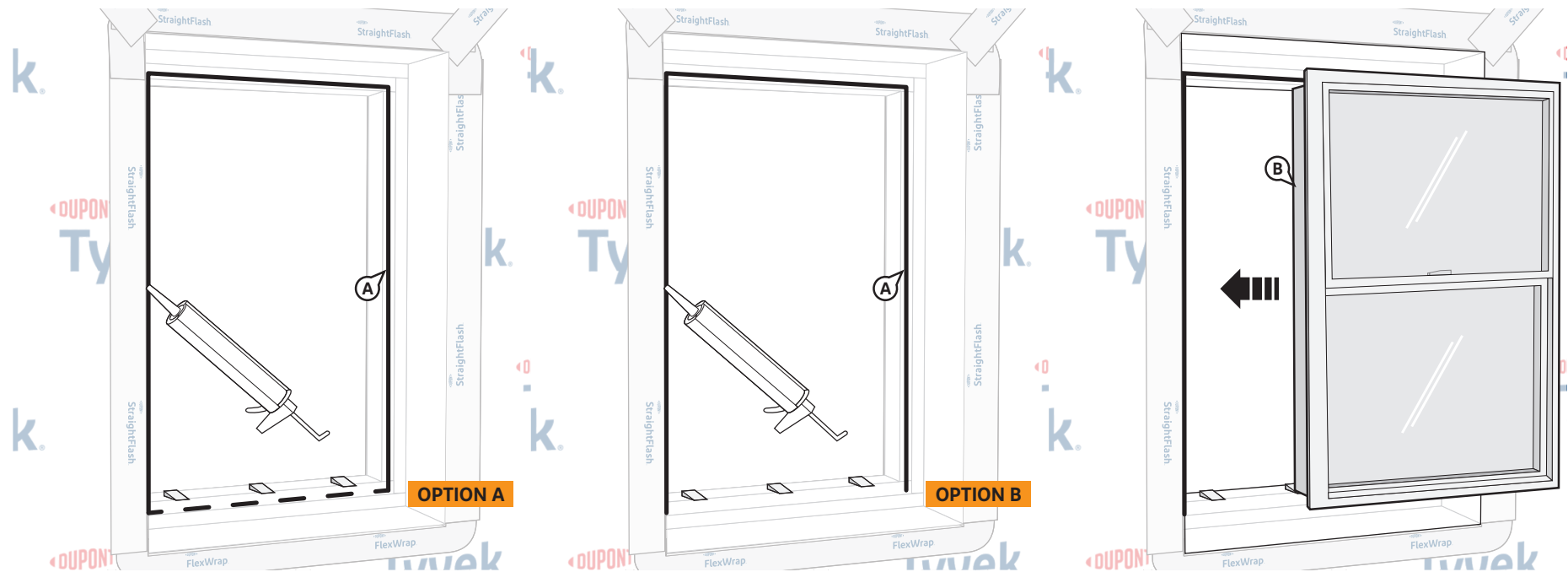

STEP 9

Install Window

A. After the **Tyvek® Fluid Applied Flashing and Joint Compound+** has skinned over, apply Tower® Residential Sealant or recommended sealant using of the options captured below:

OPTION A: Apply a continuous bead of Tower® Residential Sealant, or recommended sealant, at window head and jambs to wall or back side of window mounting flange. To allow for drainage, do not apply continuous sealant bead along sill. Ensure a minimum 2" wide drainage gap in the sealant bead within 4" from each corner of the jamb-sill interface. Continue applying sealant along the sill with additional 2" wide (min.) drainage gaps for every 6"- 12" (on center) of sill width.

OPTION B: Apply a continuous bead of Tower® Residential Sealant, or recommended sealant, at window head and jambs to wall or back side of window mounting flange. To allow for drainage, do not apply sealant bead along sill.

B. Install window per manufacturer's instructions.

Hybrid Installation Methods for DuPont Self-Adhered Flashing Products and DuPont™ Tyvek® Fluid Applied Products Installed AFTER the DuPont™ Tyvek® WRB

Integral Flanged Window with Shallow (Up to 4") Recessed Opening

Method 1: Using "Wrap the Cavity" Method along Edge of Rough Opening with DuPont Self-Adhered Flashing Products and DuPont™ Tyvek® Fluid Applied Flashing and Joint Compound+

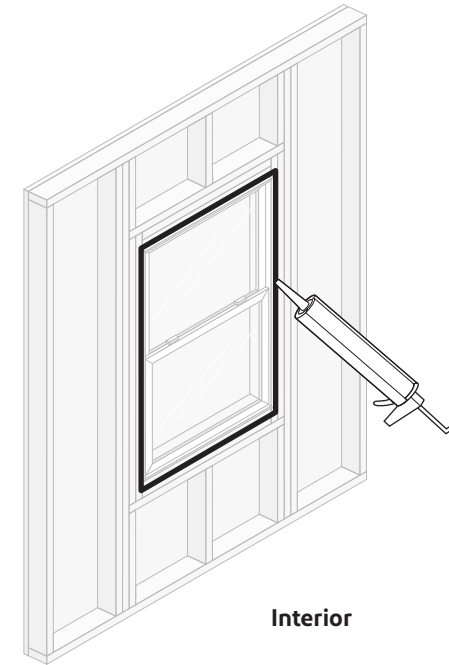
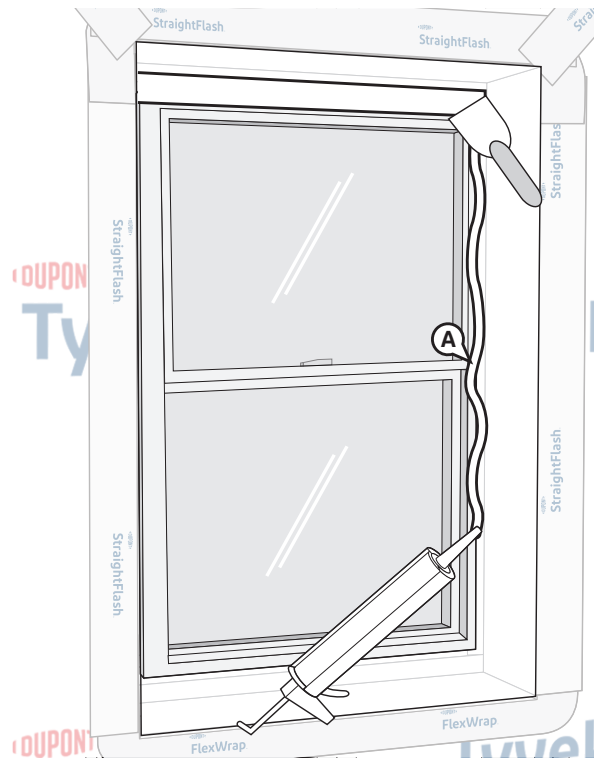

STEP 10

- Apply a continuous bead of **DuPont™ Tyvek® Fluid Applied Flashing and Joint Compound+** over the head and jamb flanges, and along the interface between the flange and the wall. **Do not apply across bottom sill flange to allow for drainage.**
- Use a small trowel to smooth **Tyvek® Fluid Applied Flashing and Joint Compound+** to approximately 2" wide x 60 mils thick, extending 1" on either side of flange/wall interface, and covering all holes and screws in the flange.
- Upon completion, inspect surfaces to ensure that **Tyvek® Fluid Applied Flashing and Joint Compound+** is continuous and free of any voids or pinholes.

OPTIONAL: If installing a drip cap as part of the window installation, see [Drip Cap Installation](#) on the next page.

STEP 11

Final Step

Apply a continuous bead of Tower® Residential Sealant or recommended sealant (and backer rod as necessary) around the window opening at the interior. It is also acceptable to use **Great Stuff Pro™ Window & Door Polyurethane Foam Sealant**, or recommended foam. When using Tower® Residential Sealant, tool sealant bead flat to allow the natural curing process to create a concave shape. Be sure that the sealant penetrates the grooves of the DuPont™ FlexWrap™ around the sill. When using **Great Stuff Pro™ Window & Door Polyurethane Foam Sealant** in perimeter openings less than 1/2", apply using the plastic extension tip for the **Great Stuff Pro™ Dispensing Gun** during installation.

Hybrid Installation Methods for DuPont Self-Adhered Flashing Products and DuPont™ Tyvek® Fluid Applied Products Installed AFTER the DuPont™ Tyvek® WRB

Integral Flanged Window with Shallow (Up to 4") Recessed Opening

Method 1: Using "Wrap the Cavity" Method along Edge of Rough Opening with DuPont Self-Adhered Flashing Products and DuPont™ Tyvek® Fluid Applied Flashing and Joint Compound+

Drip Cap Installation

After the window is installed and the **DuPont™ Tyvek® Fluid Applied Flashing and Joint Compound+** has cured, a drip cap can be installed at the window head flange and integrated with the **Tyvek® Fluid Applied Flashing and Joint Compound+** installed at the head of the window.

NOTE: When using this method, the vertical leg of the drip cap must not be taller than the window head flange when installed.

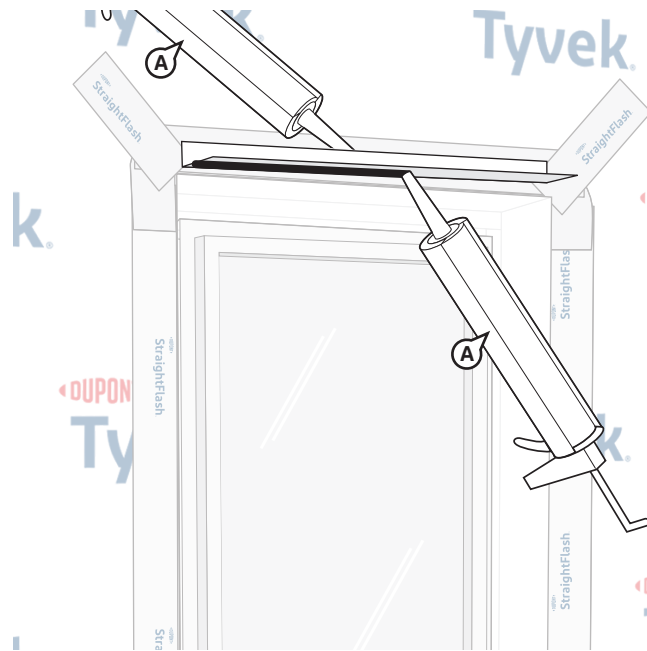

A. Apply a continuous bead of Tower® Residential Sealant or recommended sealant, on the rear side of the vertical leg and a bead on the rear side of the bottom horizontal leg. Install the drip cap tight against the window head flange per the drip cap manufacturer's instructions.

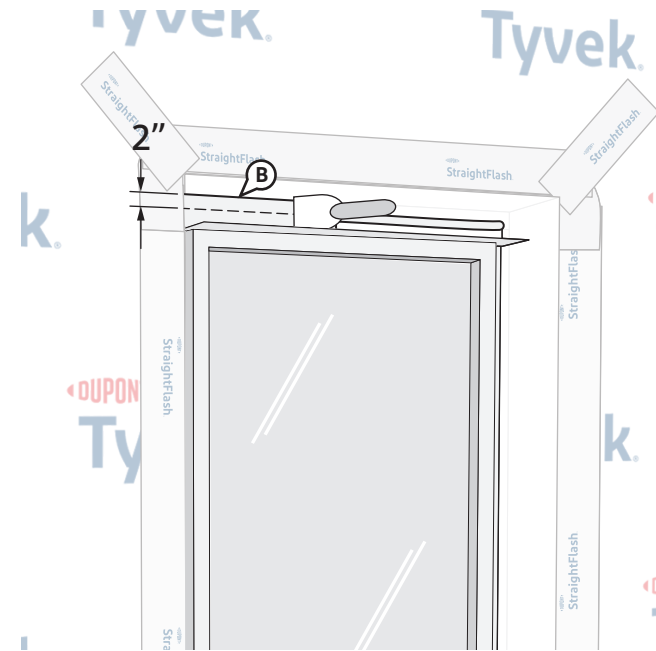

B. Apply a bead of **Tyvek® Fluid Applied Flashing and Joint Compound+** along the top edge of the drip cap and trowel or brush to cover the vertical leg, extending 2" onto the recessed wall surface if possible.

Hybrid Installation Methods for DuPont Self-Adhered Flashing Products and DuPont™ Tyvek® Fluid Applied Products Installed AFTER the DuPont™ Tyvek® WRB

Integral Flanged Window with Shallow (Up to 4") Recessed Opening

Method 2: Using Single Pieces of DuPont™ FlexWrap™ at the Sill and Head with DuPont™ Tyvek® Fluid Applied Flashing and Joint Compound+

This method applies to the following products: DuPont™ StraightFlash™, DuPont™ FlexWrap™, and Tyvek® Fluid Applied Flashing and Joint Compound+

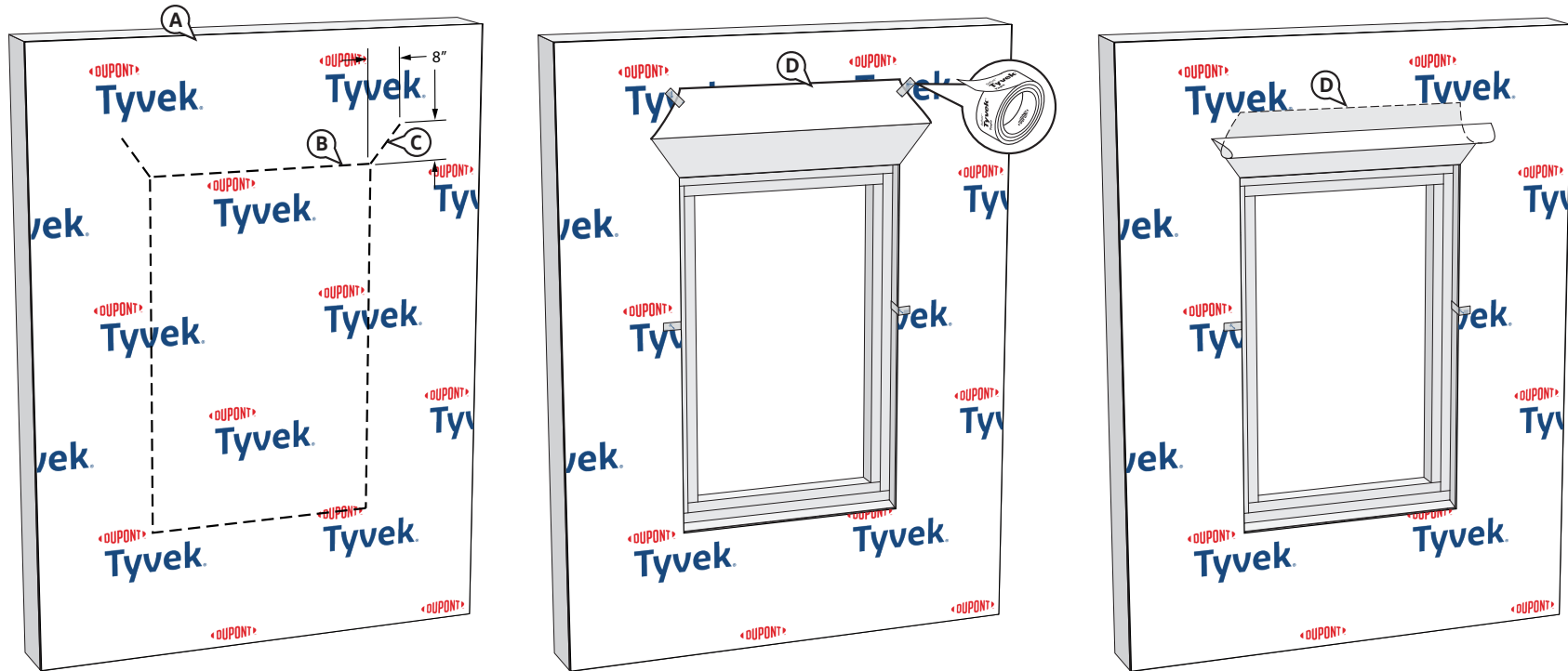

STEP 1

Prepare the Tyvek® WRB for Window Installation

OPTIONAL: Refer to the [Alternative Installation Considerations](#) section for guidance regarding trimming the head flap while preparing the Tyvek® WRB if desired instead.

- Wrap wall as shown in the applicable Tyvek® WRB Installation Guideline that can be found at building.dupont.com. Do not install fasteners within 9" from the perimeter of the rough opening.
- Make a cut in the Tyvek® WRB along the perimeter of the rough opening. Ensure that the Tyvek® WRB is cut flush with the sheathing and is not wrapped into the rough opening.

- Cut two 45 degree slits extending a minimum of 8" from the corner of the window head, up and away from the window opening. This will create a flap above the rough opening to expose sheathing or framing members to allow head flashing installation.

- Flip head flap up and temporarily secure with DuPont™ Tyvek® Tape.

ALTERNATE METHOD TO SECURE HEAD FLAP: In lieu of temporarily taping, the head flap can be tucked under the Tyvek® WRB.

Hybrid Installation Methods for DuPont Self-Adhered Flashing Products and DuPont™ Tyvek® Fluid Applied Products Installed AFTER the DuPont™ Tyvek® WRB

Integral Flanged Window with Shallow (Up to 4") Recessed Opening

Method 2: Using Single Pieces of DuPont™ FlexWrap™ at the Sill and Head with DuPont™ Tyvek® Fluid Applied Flashing and Joint Compound+

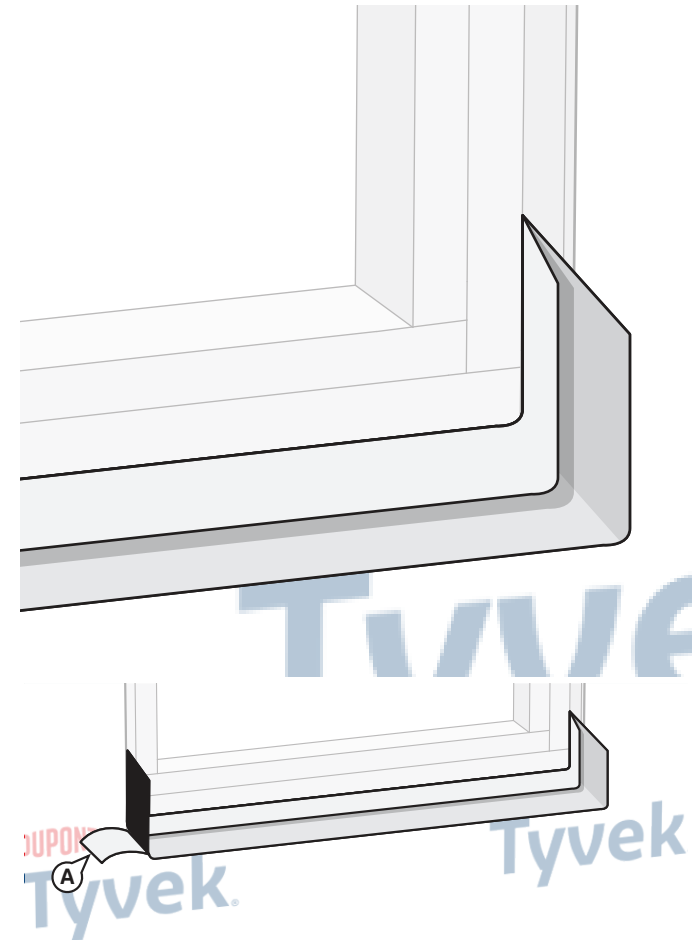
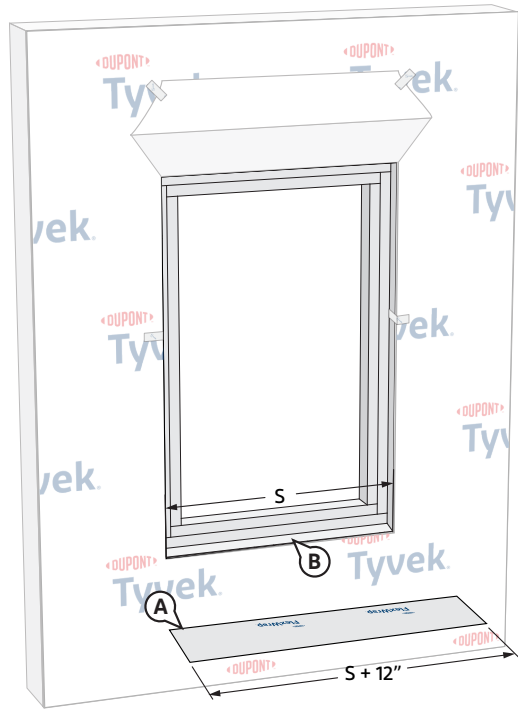

STEP 2

Prepare FlexWrap™ for Installation

- Cut **FlexWrap™** at least 12" **LONGER** than width of recessed sill (S) plane. Use roll widths sufficient to achieve adhesion to the face of stud framing, ensuring 2"- 3" adhesion onto the face of the wall.
- Inspect installation surface to ensure surface is free of dirt or substances that could interfere with adhesion as well as any sharp protrusions.

STEP 3

Install FlexWrap™ at Sill and Jambs

- Remove widest piece of release paper. Position on horizontal sill at the inside corner with a 6" minimum up each jamb. Adhere to recessed plane.

Hybrid Installation Methods for DuPont Self-Adhered Flashing Products and DuPont™ Tyvek® Fluid Applied Products Installed AFTER the DuPont™ Tyvek® WRB

Integral Flanged Window with Shallow (Up to 4”) Recessed Opening

Method 2: Using Single Pieces of DuPont™ FlexWrap™ at the Sill and Head with DuPont™ Tyvek® Fluid Applied Flashing and Joint Compound+

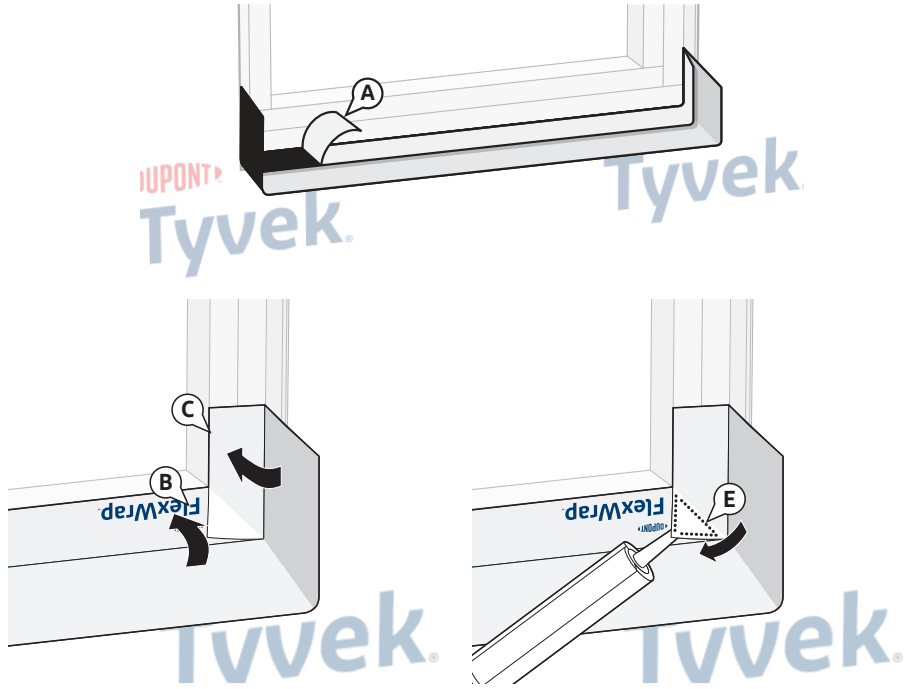

STEP 4

Install FlexWrap™ on the Face of the Rough Opening at Sill

- Remove remaining release paper and create **FlexWrap™** recessed window corner.
- Adhere exposed butyl to the face of the stud framing and **DuPont Self-Adhered Flashing Products**. Fold the exposed butyl along the horizontal portion onto the stud framing towards sill of rough opening.
- Fold the jamb portion of the exposed butyl onto the stud framing and create a butyl-to-butyl seal, resulting in a triangular flap at the corner.
- Repeat Step C for opposite corner.
- OPTIONAL:** Apply a bead of Tower® Residential Sealant or recommended sealant inside the corner flap behind the loose triangular flap of the corner piece. Press the loose triangular onto the sealant in the corner piece.

NOTE: For double stud framing, the **FlexWrap™** recessed window corners should extend a minimum of 3” onto the face of the recessed window frame and cover the seams between the studs. For single stud window frames, the **FlexWrap™** recessed window corner should extend and cover face of the stud framing.

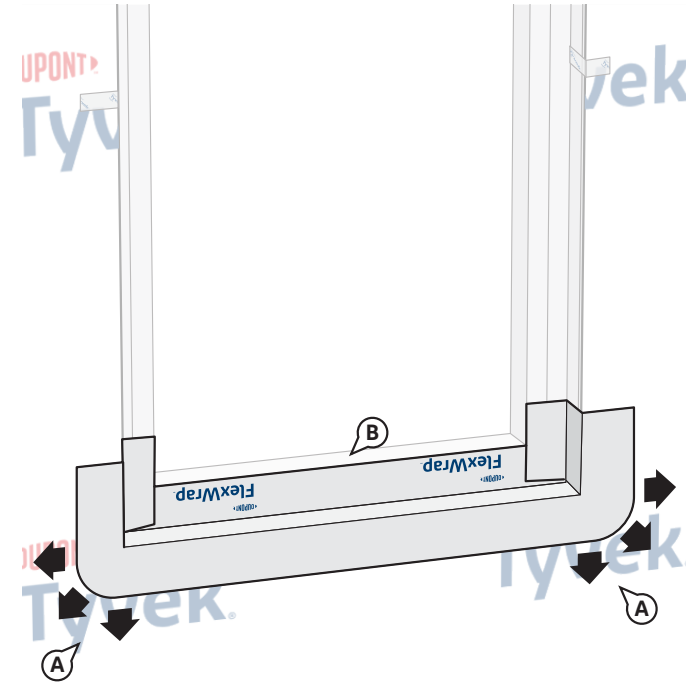

STEP 5

Install FlexWrap™ on Face of Wall

- Fan out the **FlexWrap™** at corners and adhere onto **Tyvek® WRB**. Continue adhering onto face of wall along sill. Coverage of **FlexWrap™** should be 2”-3” onto the face of the wall.
- Firmly press sill flashing to ensure full adhesion on all surfaces. Eliminate wrinkles and bubbles by smoothing surface and repositioning as necessary.

Hybrid Installation Methods for DuPont Self-Adhered Flashing Products and DuPont™ Tyvek® Fluid Applied Products Installed AFTER the DuPont™ Tyvek® WRB

Integral Flanged Window with Shallow (Up to 4") Recessed Opening

Method 2: Using Single Pieces of DuPont™ FlexWrap™ at the Sill and Head with DuPont™ Tyvek® Fluid Applied Flashing and Joint Compound+

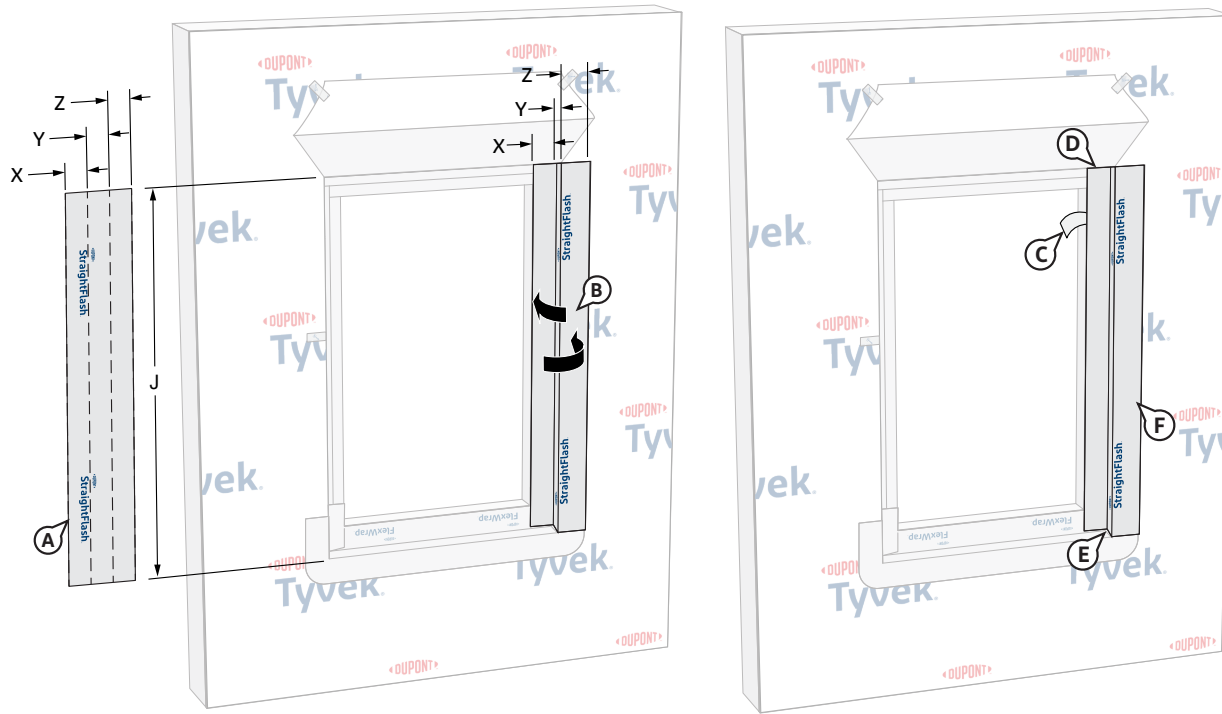

STEP 6

Install* DuPont™ StraightFlash™ at Jamb

- A. Cut a piece of **StraightFlash™** that is the length of the outer jamb (J).
- B. Fold the **StraightFlash™** lengthwise using the measurements (X, Y and Z) shown in Table 1 below, creating sharp creases to help achieve sharp corners when release paper is removed.

Table 1: Jamb Flashing for Shallow Recessed Flanged Window Condition

	X	Y	Z
9" StraightFlash™ (single stud)	2"	4"	3"
9" StraightFlash™ (single stud)	2"	5"	2"
9" StraightFlash™ (double stud)	3"	3"	3"
9" StraightFlash™ (double stud)	3"	4"	2"

- C. Remove release liner.
- D. Position and install jamb flashing.
- E. Roll flashing into the corner and along the recessed plane
- F. Extend remaining flashing to face of wall. Coverage of **StraightFlash™** should be 2"–3" onto the face of the wall.
- G. Firmly press sill flashing to ensure full adhesion on all surfaces. Eliminate wrinkles and bubbles by smoothing surface and repositioning as necessary.

Hybrid Installation Methods for DuPont Self-Adhered Flashing Products and DuPont™ Tyvek® Fluid Applied Products Installed AFTER the DuPont™ Tyvek® WRB

Integral Flanged Window with Shallow (Up to 4") Recessed Opening

Method 2: Using Single Pieces of DuPont™ FlexWrap™ at the Sill and Head with DuPont™ Tyvek® Fluid Applied Flashing and Joint Compound+

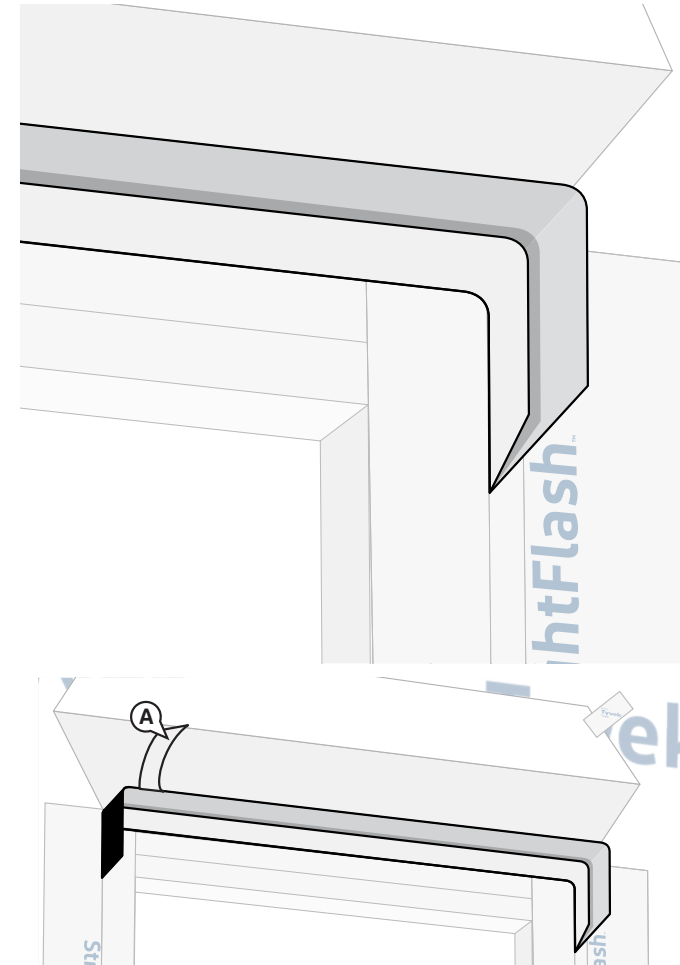
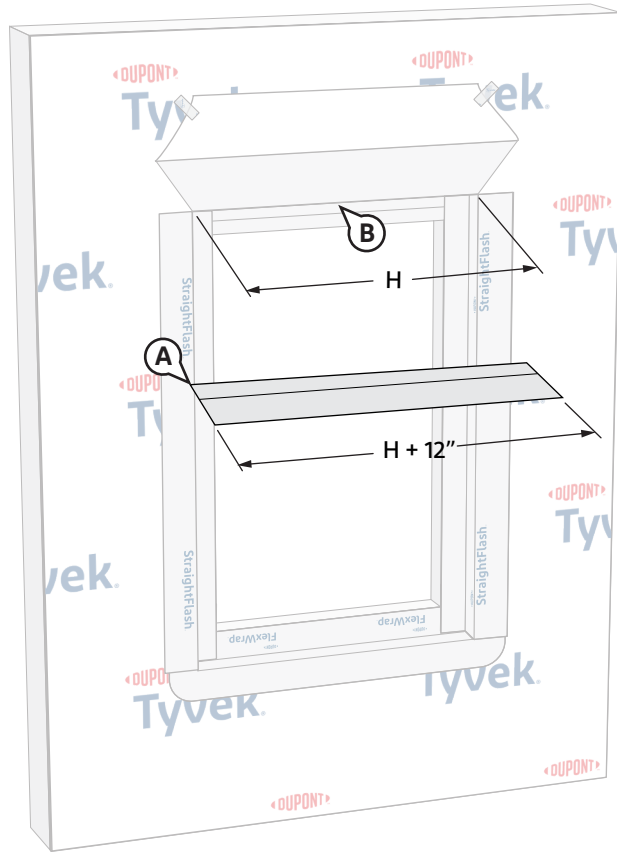

STEP 7

Prepare FlexWrap™ for Installation

- Cut **FlexWrap™** at least 12" **LONGER** than width of recessed head (H) plane. Use roll widths sufficient to achieve adhesion to the face of stud framing, ensuring 2"– 3" adhesion onto the face of the wall.
- Inspect installation surface to ensure surface is free of dirt or substances that could interfere with adhesion as well as any sharp protrusions.

STEP 8

Install FlexWrap™ at Head and Jambs

- Remove widest piece of release paper. Position on horizontal head at the inside corner with a 6" minimum down each jamb. Adhere to recessed plane.

Hybrid Installation Methods for DuPont Self-Adhered Flashing Products and DuPont™ Tyvek® Fluid Applied Products Installed AFTER the DuPont™ Tyvek® WRB

Integral Flanged Window with Shallow (Up to 4") Recessed Opening

Method 2: Using Single Pieces of DuPont™ FlexWrap™ at the Sill and Head with DuPont™ Tyvek® Fluid Applied Flashing and Joint Compound+

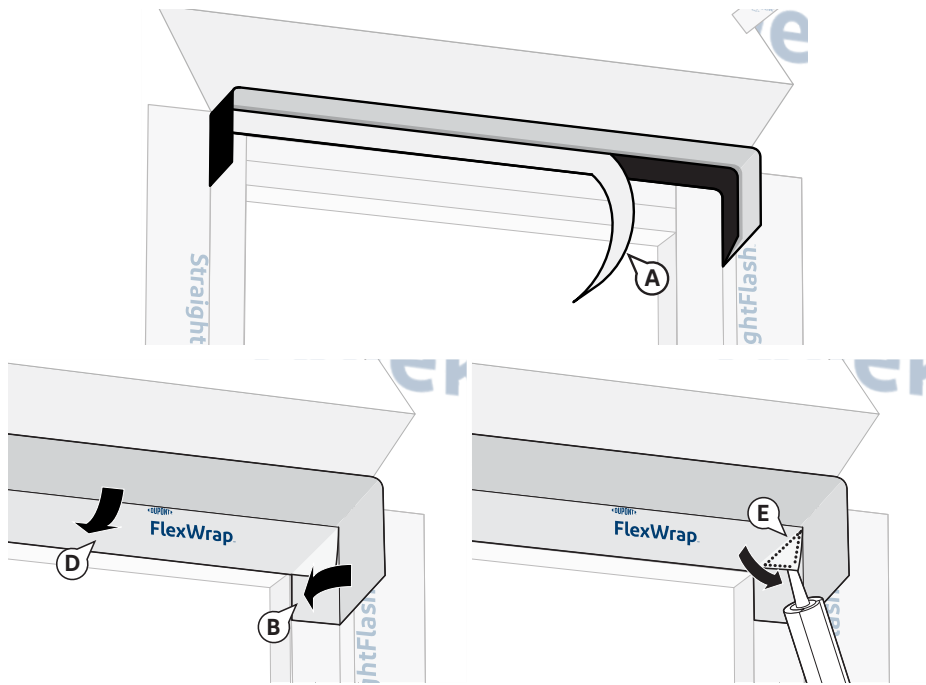

STEP 9

Install FlexWrap™ on the Face of the Rough Opening at Head

- Remove remaining release paper and create **FlexWrap™** recessed window corner.
- Adhere exposed butyl to the face of the stud framing and **DuPont Self-Adhered Flashing Products**. Fold the exposed butyl along the jamb portion onto the stud framing.
- Fold the exposed butyl along the head portion onto the stud framing and create a butyl-to-butyl seal, resulting in a triangular flap at the corner.
- Repeat Step C for opposite corner.
- OPTIONAL:** Apply a bead of Tower® Residential Sealant or recommended sealant inside the corner flap behind the loose triangular flap of the corner piece. Press the loose triangular onto the sealant in the corner piece.

NOTE: For double stud framing, the **FlexWrap™** recessed window corners should extend a minimum of 3" onto the face of the recessed window frame and cover the seams between the studs. For single stud window frames, the **FlexWrap™** recessed window corner should extend and cover face of the stud framing.

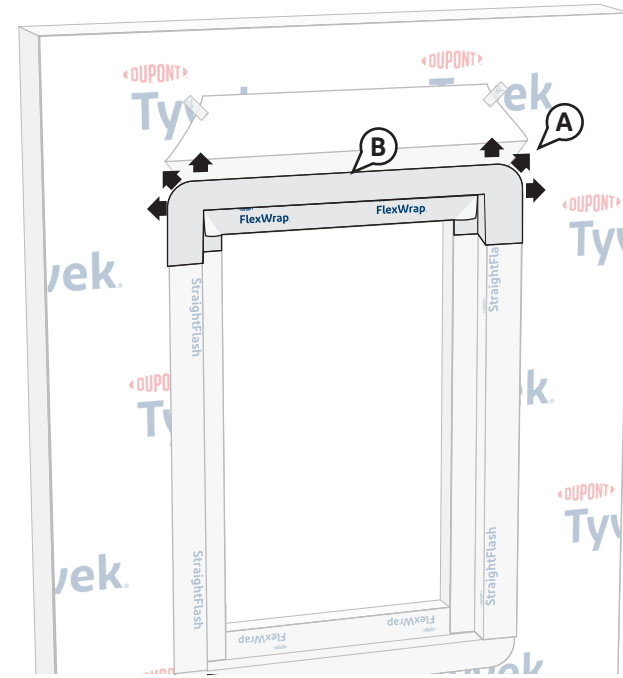

STEP 10

Install FlexWrap™ at Window Head

- Fan out the **FlexWrap™** at corners and adhere onto **Tyvek® WRB**. Continue adhering onto face of wall along sill. Coverage of **FlexWrap™** should be 2"– 3" onto the face of the wall.
- Firmly press sill flashing to ensure full adhesion on all surfaces. Eliminate wrinkles and bubbles by smoothing surface and repositioning as necessary.

NOTE: For exterior gypsum sheathing, apply a recommended adhesive/primer to the exposed sheathing. An adhesive/primer is not required for wood-based sheathing, except when applying flashing during adverse weather conditions.

Hybrid Installation Methods for DuPont Self-Adhered Flashing Products and DuPont™ Tyvek® Fluid Applied Products Installed AFTER the DuPont™ Tyvek® WRB

Integral Flanged Window with Shallow (Up to 4”) Recessed Opening

Method 2: Using Single Pieces of DuPont™ FlexWrap™ at the Sill and Head with DuPont™ Tyvek® Fluid Applied Flashing and Joint Compound+

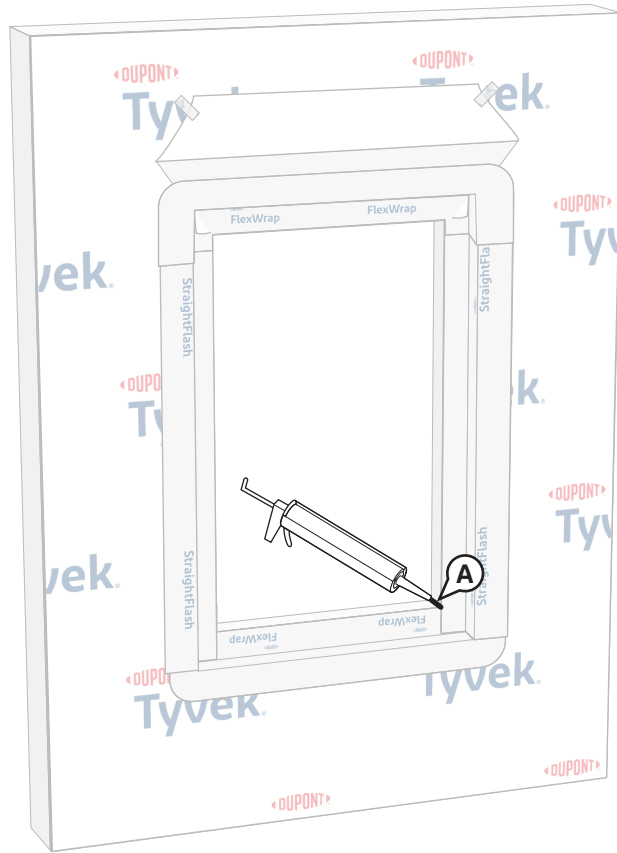

STEP 11

Prepare Rough Opening

- A. Pretreat all inside corners, nail holes and small gaps by applying a bead of **Tyvek® Fluid Applied Flashing and Joint Compound+** or recommended sealant to the surface. If gaps in framing are over 1/4” wide, apply self-adhered fiberglass mesh tape over the gap or into corner before applying sealant. Primer may be needed to promote adhesion of the mesh tape.

Hybrid Installation Methods for DuPont Self-Adhered Flashing Products and DuPont™ Tyvek® Fluid Applied Products Installed AFTER the DuPont™ Tyvek® WRB

Integral Flanged Window with Shallow (Up to 4") Recessed Opening

Method 2: Using Single Pieces of DuPont™ FlexWrap™ at the Sill and Head with DuPont™ Tyvek® Fluid Applied Flashing and Joint Compound+

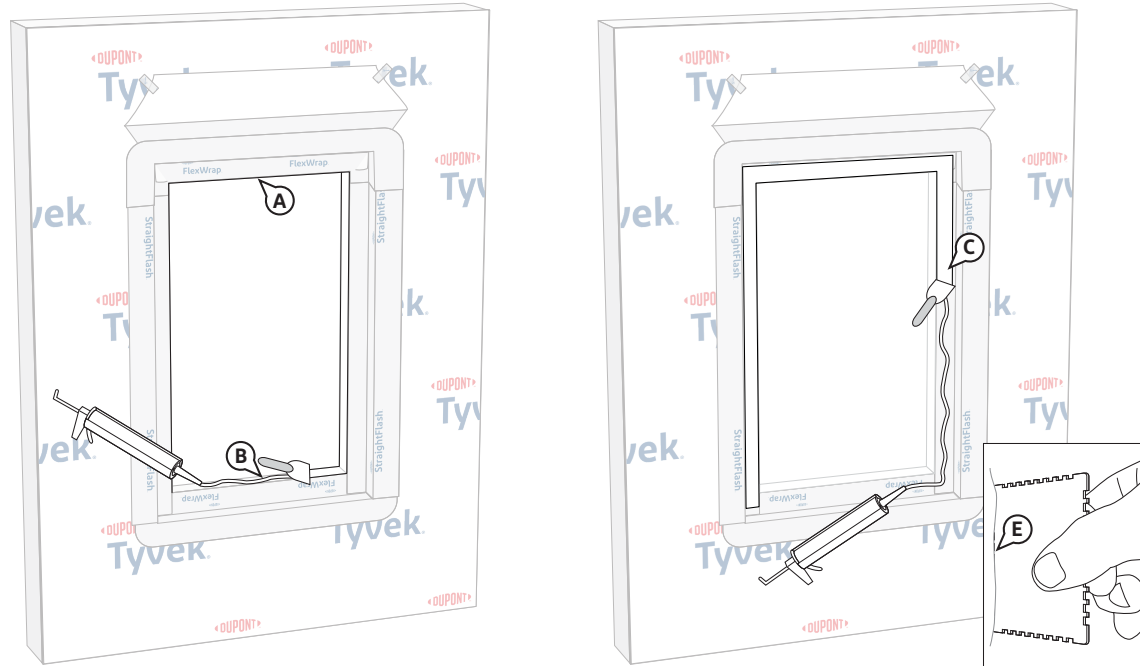

STEP 12

Apply Tyvek® Fluid Applied Flashing and Joint Compound+

After the **Tyvek® Fluid Applied Flashing and Joint Compound+** or recommend sealant pretreatment has skinned over, begin applying **Tyvek® Fluid Applied Flashing and Joint Compound+**. DuPont recommends using a stiff disposable brush or trowel to apply.

- Begin applying **Tyvek® Fluid Applied Flashing and Joint Compound+** at the head of the opening and work down to the jambs and then sill.
- Continue to apply the **Tyvek® Fluid Applied Flashing and Joint Compound+** over the entire inside portion of the rough opening.
- Extend product application to face of window framing overlapping the **DuPont™ FlexWrap™** and **DuPont™ StraightFlash™** by 2"– 3".

- Be sure to work the **Tyvek® Fluid Applied Flashing and Joint Compound+** into any small cracks, holes, and edges of the **FlexWrap™** and **StraighFlash™**.
- Tyvek® Fluid Applied Flashing and Joint Compound+** should be applied at 25 mils thick. Use a wet mil thickness gauge to check application thickness. Upon completion, inspect surface to ensure that **Tyvek® Fluid Applied Flashing and Joint Compound+** is continuous and **free of any voids or pinholes**.

Hybrid Installation Methods for DuPont Self-Adhered Flashing Products and DuPont™ Tyvek® Fluid Applied Products Installed AFTER the DuPont™ Tyvek® WRB

Integral Flanged Window with Shallow (Up to 4") Recessed Opening

Method 2: Using Single Pieces of DuPont™ FlexWrap™ at the Sill and Head with DuPont™ Tyvek® Fluid Applied Flashing and Joint Compound+

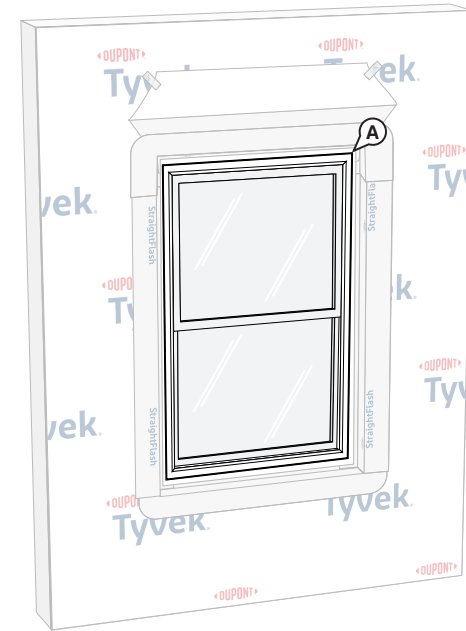
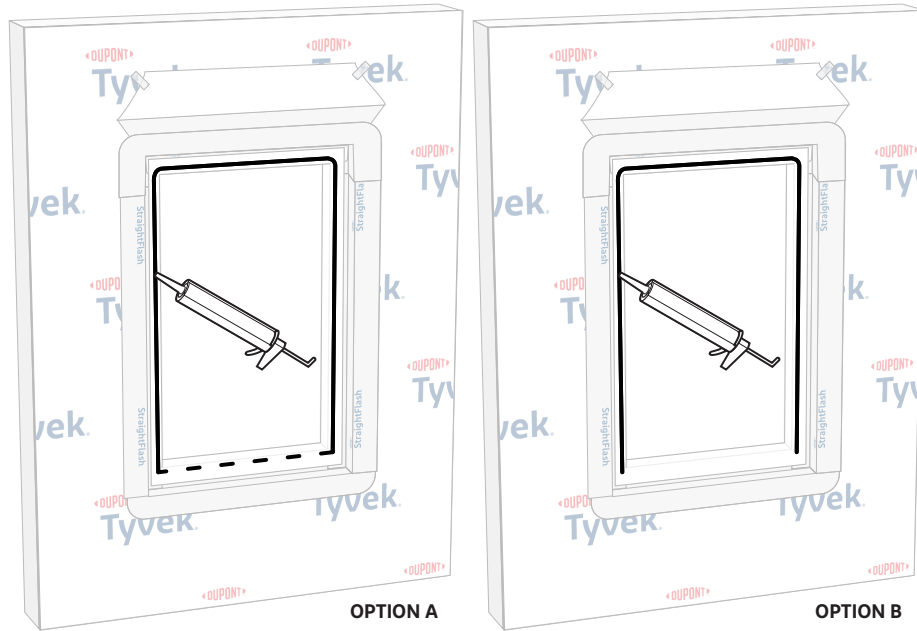

STEP 13

OPTION A: Apply a continuous bead of Tower® Residential Sealant, or recommended sealant, at window head and jambs to wall or back side of window mounting flange. To allow for drainage, do not apply continuous sealant bead along sill. Ensure a minimum 2" wide drainage gap in the sealant bead within 4" from each corner of the jamb-sill interface. Continue applying sealant along the sill with additional 2" wide (min.) drainage gaps for every 6"– 12" (on center) of sill width.

OPTION B: Apply a continuous bead of Tower® Residential Sealant, or recommended sealant, at window head and jambs to wall or back side of window mounting flange. To allow for drainage, do not apply sealant bead along sill.

STEP 14

Install Window

A. Install integral flanged window per manufacturer's instructions

Hybrid Installation Methods for DuPont Self-Adhered Flashing Products and DuPont™ Tyvek® Fluid Applied Products Installed AFTER the DuPont™ Tyvek® WRB

Integral Flanged Window with Shallow (Up to 4”) Recessed Opening

Method 2: Using Single Pieces of DuPont™ FlexWrap™ at the Sill and Head with DuPont™ Tyvek® Fluid Applied Flashing and Joint Compound+

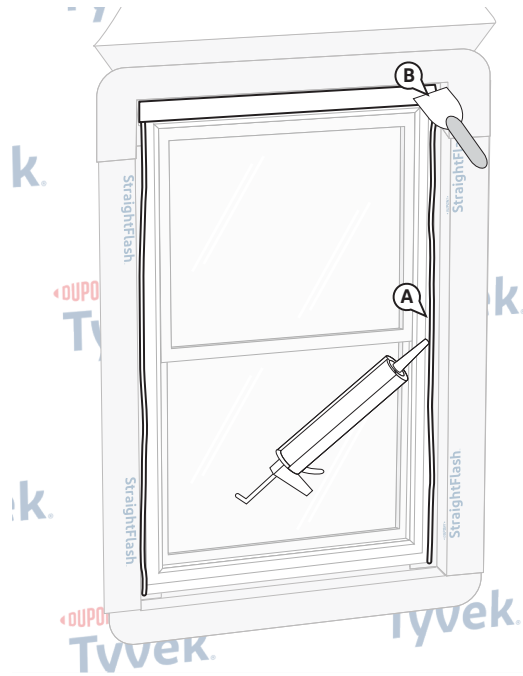

STEP 15

- Apply a continuous bead of **DuPont™ Tyvek® Fluid Applied Flashing and Joint Compound+** over the head and jamb flanges, and along the interface between the flange and the wall. **Do not apply across bottom sill flange to allow for drainage.**
- Use a small trowel to smooth **Tyvek® Fluid Applied Flashing and Joint Compound+** to approximately 2” wide x 60 mils thick, extending 1” on either side of flange/wall interface, and covering all holes and screws in the flange.
- Upon completion, inspect surfaces to ensure that **Tyvek® Fluid Applied Flashing and Joint Compound+** is continuous and free of any voids or pinholes.

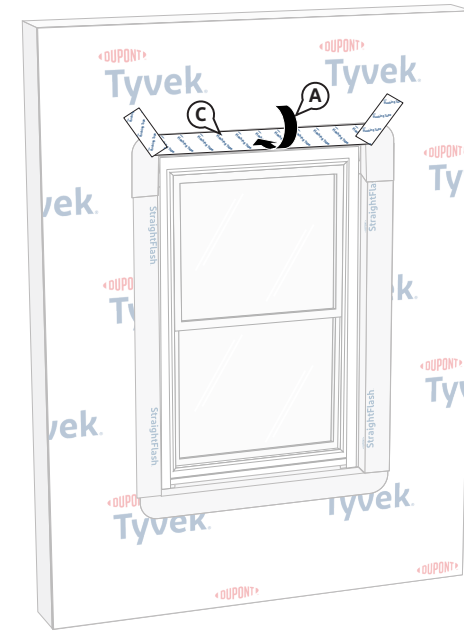

STEP 16

Secure Upper Flap

- Flip down upper flap of **Tyvek® WRB** so it lays flat across head flashing.
- Cut ~1” strip of the **Tyvek® WRB** at lower horizontal edge of head flap.

NOTE: Skip this step if the head flap was trimmed while preparing the **Tyvek® WRB** per the [Alternative Installation Considerations](#) section.

- Terminate head flap by continuously sealing the horizontal then diagonal seams with **DuPont™ Flashing Tape** or **DuPont™ StraightFlash™**. If additional drainage is desired and **an air barrier is not required**, skip-taping head flap with a maximum of two (2) 2” gaps for every 3’ of window is acceptable.

NOTE: Install mechanical fasteners through flashing as needed for increased holding power. See the table in the [Applicable Structures and Performance Criteria](#) section for more information on air barrier requirements and head flap terminations.

Hybrid Installation Methods for DuPont Self-Adhered Flashing Products and DuPont™ Tyvek® Fluid Applied Products Installed AFTER the DuPont™ Tyvek® WRB

Integral Flanged Window with Shallow (Up to 4”) Recessed Opening

Method 2: Using Single Pieces of DuPont™ FlexWrap™ at the Sill and Head with DuPont™ Tyvek® Fluid Applied Flashing and Joint Compound+

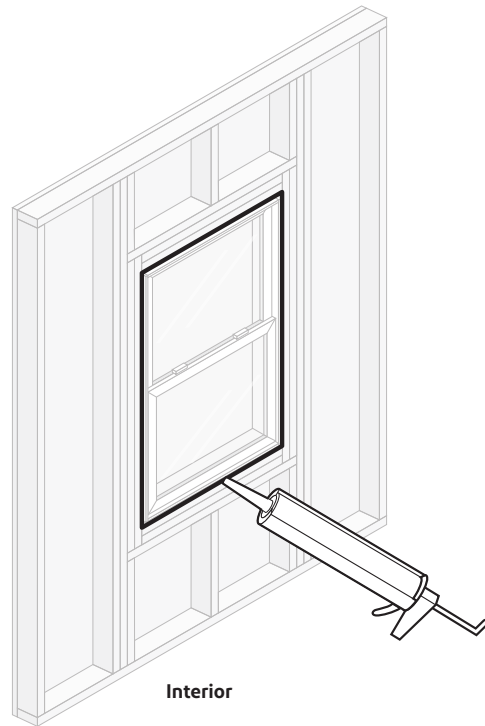

STEP 17

Install Interior Perimeter Seal

Apply a continuous bead of Tower® Residential Sealant or recommended sealant (and backer rod as necessary) around the window opening at the interior. It is also acceptable to use **Great Stuff Pro™ Window & Door Polyurethane Foam Sealant**, or recommended foam. When using Tower® Residential Sealant, tool sealant bead flat to allow the natural curing process to create a concave shape. Be sure that the sealant penetrates the grooves of the **DuPont™ FlexWrap™** around the sill. When using **Great Stuff Pro™ Window & Door Polyurethane Foam Sealant** in perimeter openings less than 1/2”, apply using the plastic extension tip for the **Great Stuff Pro™ Dispensing Gun** during installation.

Installation Methods for DuPont Self-Adhered Flashing Products Installed AFTER the DuPont™ Tyvek® WRB

Integral Flanged Window with Deep (Greater than 4") Recessed Opening

Field Preparation of Recessed Window Corner Using DuPont™ FlexWrap™

The method illustrated in this installation guideline uses 6" wide FlexWrap™ to fabricate recessed window corners for recesses that are greater than 4" deep with double stud framing. The same method can be used to create recessed window corners using 9" wide FlexWrap™.

This installation guideline also applies to single stud framing which is limited to the use of 6" FlexWrap™ for fabrication of recessed window corners. See summary of FlexWrap™ dimensions below.

Single Stud Framing

The images below show the 6" FlexWrap™ recessed window corner installed on a single stud window. Note that the FlexWrap™ recessed window corner extending slightly beyond the face of the stud (left) can be fully adhered onto framing (right). See [STEP 2](#) for additional information.

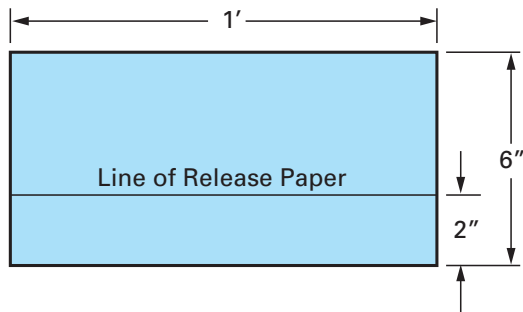
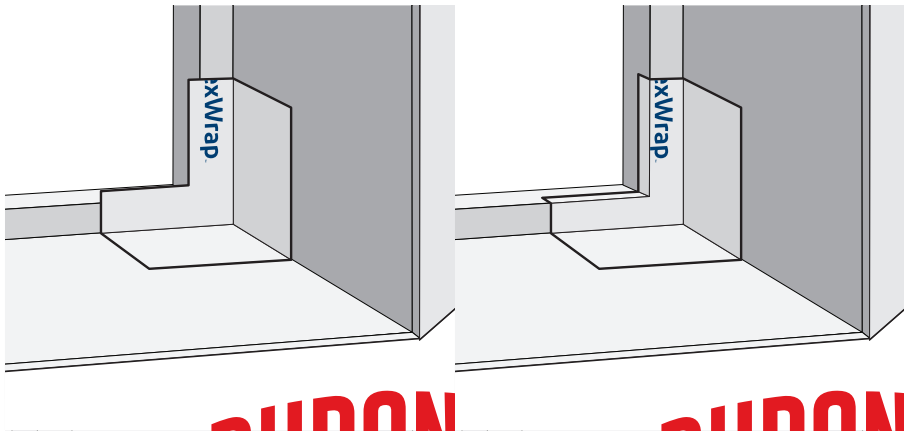

6" FlexWrap™ (for greater than 4" recesses, single stud framing)

Double Stud Framing

The following image shows the fabricated recessed window corners for a recess that is greater than 4" deep with double stud window framing using 9" FlexWrap™.

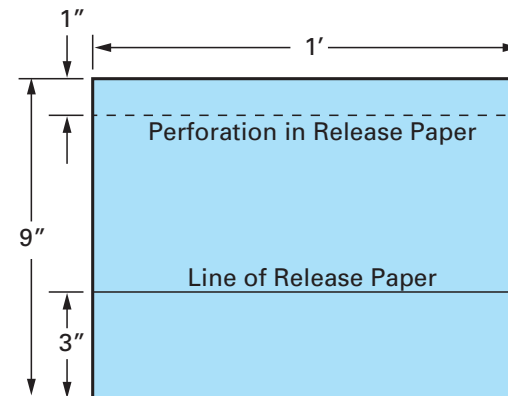
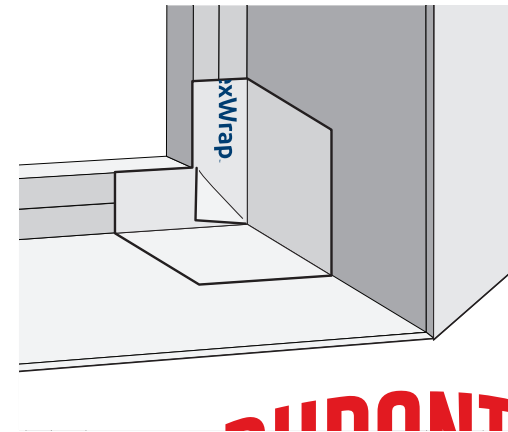

9" FlexWrap™ (for greater than 4" recesses, double stud framing)

Installation Methods for DuPont Self-Adhered Flashing Products Installed AFTER the DuPont™ Tyvek® WRB Integral Flanged Window with Deep (Greater than 4") Recessed Opening

Method 1: Depth of Recess Less Than 1/2 the Width of the Recess

This method applies to the following products: DuPont™ Flashing Tape, DuPont™ StraightFlash™, and DuPont™ FlexWrap™

This method can be used when the depth of recess is less than 1/2 the width of the recess, allowing the Tyvek® WRB jamb flaps to be folded into the rough opening to cover jamb walls of the recess.

Follow [Method 2](#) when the depth of recess is greater than 1/2 the width of the recess, which requires strips of Tyvek® WRB to cover jamb walls of the recess.

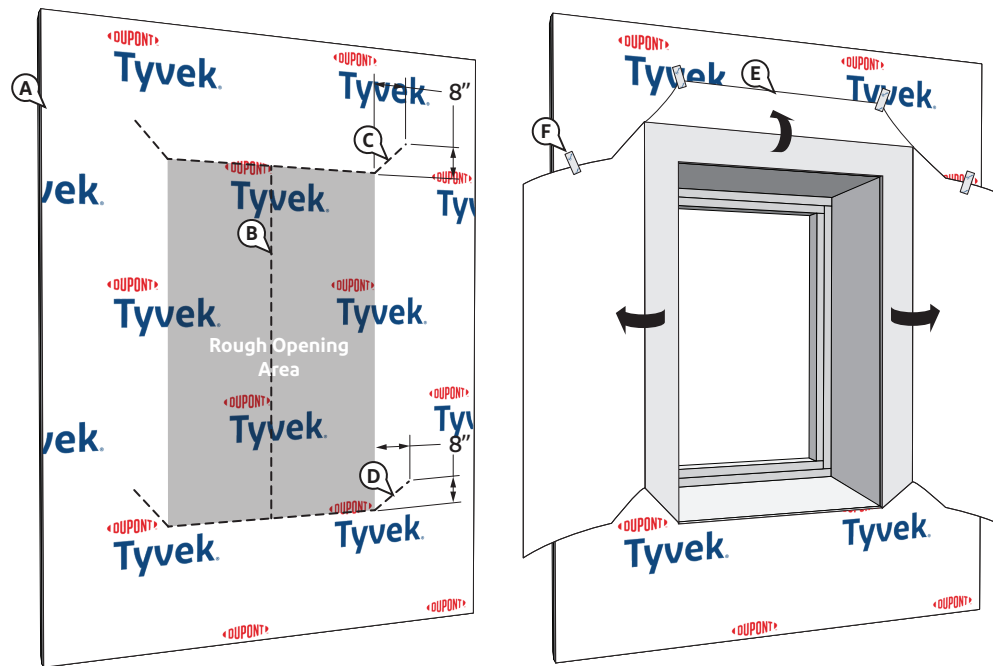

STEP 1

Prepare Tyvek® WRB Frame for Window Installation

OPTIONAL: Refer to the [Alternative Installation Considerations](#) section for guidance regarding trimming the head flap while preparing the Tyvek® WRB if desired instead.

- Wrap wall as shown in the applicable Tyvek® WRB Installation Guideline that can be found at building.dupont.com. Do not install fasteners within 6" of the sills and jambs of the openings and within 9" of the head of the openings.
- Make an "I-Cut" in the Tyvek® WRB. For an "I-Cut" begin with a horizontal cut across the bottom and the top of the window frame
- Cut a head flap at a 45° angle to expose 8" of sheathing to allow for head flashing installation.

- Cut two 45° slits extending from the bottom corner up and away from the window opening to expose 6"– 8" of sheathing. This will create a flap at each jamb to allow for jamb flashing installation.
- Flip the head flap up to expose the sheathing and temporarily secure with DuPont™ Tyvek® Tape.

ALTERNATIVE METHOD TO SECURE HEAD FLAP: In lieu of temporarily taping, the head flap can be tucked under the Tyvek® WRB.

- Flip the flaps to the side to expose the sheathing and temporarily secure with Tyvek® Tape.

Installation Methods for DuPont Self-Adhered Flashing Products Installed AFTER the DuPont™ Tyvek® WRB

Integral Flanged Window with Deep (Greater than 4") Recessed Opening

Method 1: Depth of Recess Less Than 1/2 the Width of the Recess

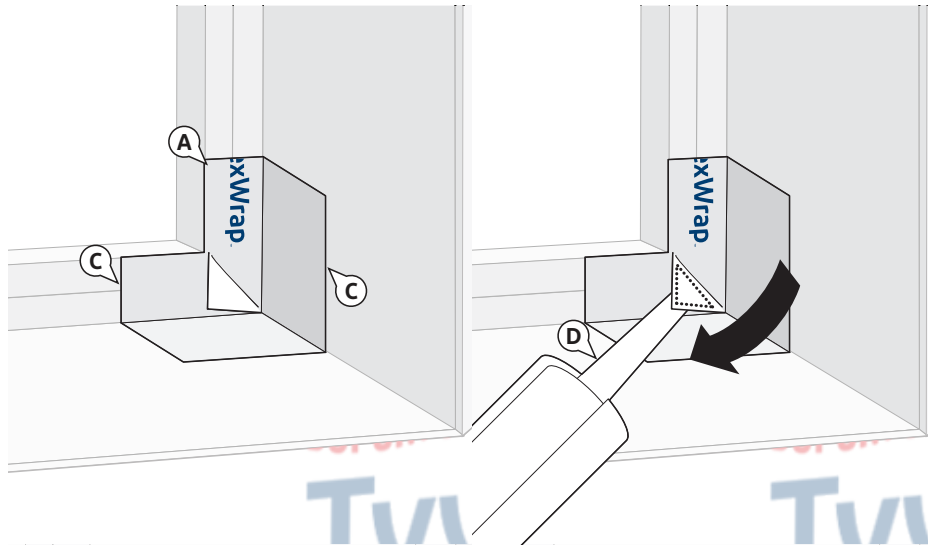

STEP 2

Install DuPont™ FlexWrap™ Recessed Window Corner at Sill

A. Place **FlexWrap™** recessed window corner into corner of recess so exposed butyl is against face of recessed window frame and adhere.

NOTE: For double stud window frames, the **FlexWrap™** recessed window corner should extend a minimum of 2" onto the face of the recessed window frame and cover the seams between the studs. For single stud window frames, the **FlexWrap™** recessed window corner extending slightly beyond the face of the stud can be fully adhered onto framing.

B. Remove remaining release paper.

C. Adhere* exposed butyl to sill and jamb surfaces of recess.

D. **OPTIONAL:** Apply a bead of Tower® Residential Sealant or recommended sealant behind the loose triangular flap within the **FlexWrap™** recessed window corner. Press down the loose triangular flap into the sealant.

E. Repeat Steps A – D for opposite side.

*Use **DuPont Self-Adhered Flashing Products** with a recommended adhesive/primer as applicable to seal directly to exterior gypsum sheathing, concrete, masonry, or other rough surfaces. An adhesive/primer is not required for wood-based sheathing except when applying flashing during adverse weather conditions.

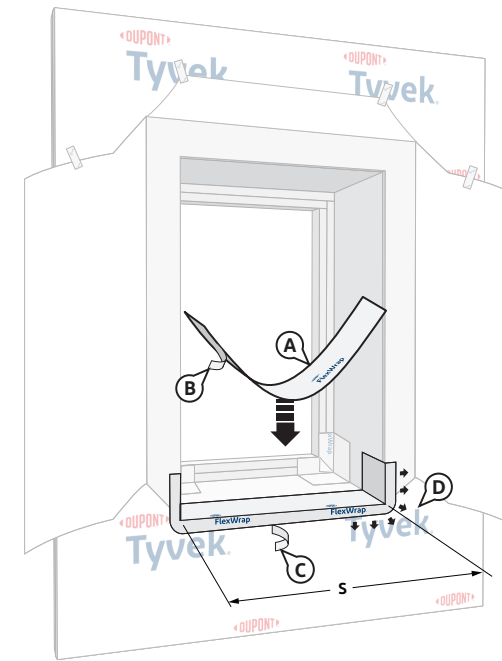

STEP 3

Install* FlexWrap™ at Outer Sill of Recessed Opening

A. Cut **FlexWrap™** at least 12" **LONGER** than width of outer sill of recess (S).

B. Remove wide piece of release paper. Position on horizontal surface of outer sill by aligning the inside edge of the narrow release paper with the face of the wall to ensure 2"– 3" of the **FlexWrap™** will be adhered to the face of the wall with a minimum of 6" up each jamb. Adhere onto horizontal surface.

C. Remove narrow release paper.

D. Fan out **FlexWrap™** at bottom corners onto face of wall. Continue adhering onto face of wall along sill. Coverage of **FlexWrap™** should be 2"– 3" onto the face of the wall.

NOTE: DuPont™ Tyvek® Certified Installers may install a 3-piece head (and sill) detail for window openings less than 6 ft. wide. For windows greater than 6 ft. wide, see the [Special Considerations](#) section for more information regarding the 3-piece head/sill detail. Contact your local DuPont Building Envelope Specialist for more information about the Certified Installer program.

Installation Methods for DuPont Self-Adhered Flashing Products Installed AFTER the DuPont™ Tyvek® WRB Integral Flanged Window with Deep (Greater than 4") Recessed Opening

Method 1: Depth of Recess Less Than 1/2 the Width of the Recess

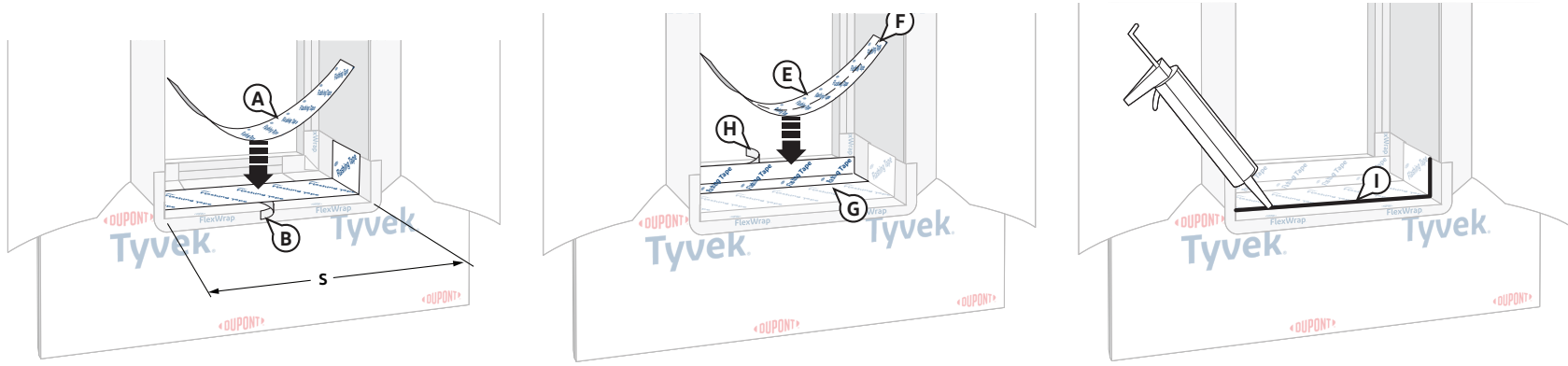

STEP 4

Install* DuPont™ Flashing Tape at Sill of Recess

DuPont™ Flashing Tape will be used at the sill of the recess in this step to overlap the **DuPont™ FlexWrap™** at the outer sill and extend onto the face of the stud framing at the inner window sill. The number of layers and product widths can be modified accordingly but **all overlaps need to be a minimum of 2"**. All but the last layer of **DuPont™ Flashing Tape** will extend 6" min. up each side of the recess jamb walls. The last layer will be the width of the outer rough opening and will extend 2" min. onto the face of the stud framing at the sill of the window.

- A. Cut the first course of **DuPont™ Flashing Tape** 12" **LONGER** than outer sill (S).
- B. Remove the release paper and align on sill to overlap **FlexWrap™** by 2" and extend up each jamb wall of recess by 6". **DuPont™ Flashing Tape** should be installed tightly into the corner at the intersection of the recess sill and wall of recess. **NOTE:** The **DuPont™ Flashing Tape** on the jamb walls will have an angled offset from the window framing in recesses that have a sloped sill.
- C. Adhere exposed butyl to sill of recess and up jamb walls of recess.
- D. If necessary, repeat Step B with appropriate width of **DuPont™ Flashing Tape** to overlap the first layer of **DuPont™ Flashing Tape** by 2".
- E. Cut the last layer of **DuPont™ Flashing Tape** the length of the inner window sill (S), and use appropriate width for a minimum of 2" adhesion of butyl onto the face of the stud framing at the window sill maintaining a 2" overlap onto previous layer. **NOTE:** This dimension will need to be adjusted if the side walls of the recess are tapered.
- F. Fold to create a sharp crease that is aligned with the intersection of the recessed sill and the face of the stud framing. Tear release paper at the fold so exposed butyl can be adhered on to sill of recess. **DO NOT CUT** release paper with sharp object as this may damage the butyl and compromise protection provided by the **DuPont™ Flashing Tape**.
- G. Adhere exposed butyl on sill of recess and tight into the intersection of recessed sill and face of stud framing.
- H. Remove second release paper and adhere exposed butyl onto face of stud framing.
- I. Apply a continuous bead of Tower® Residential Sealant or recommended sealant along the edge of the overlap between the **DuPont™ Flashing Tape** and the **FlexWrap™**.

*Use **DuPont Self-Adhered Flashing Products** with a recommended adhesive/primer as applicable to seal directly to exterior gypsum sheathing, concrete, masonry, or other rough surfaces. An adhesive/primer is not required for wood-based sheathing except when applying flashing during adverse weather conditions.

Installation Methods for DuPont Self-Adhered Flashing Products Installed AFTER the DuPont™ Tyvek® WRB Integral Flanged Window with Deep (Greater than 4") Recessed Opening

Method 1: Depth of Recess Less Than 1/2 the Width of the Recess

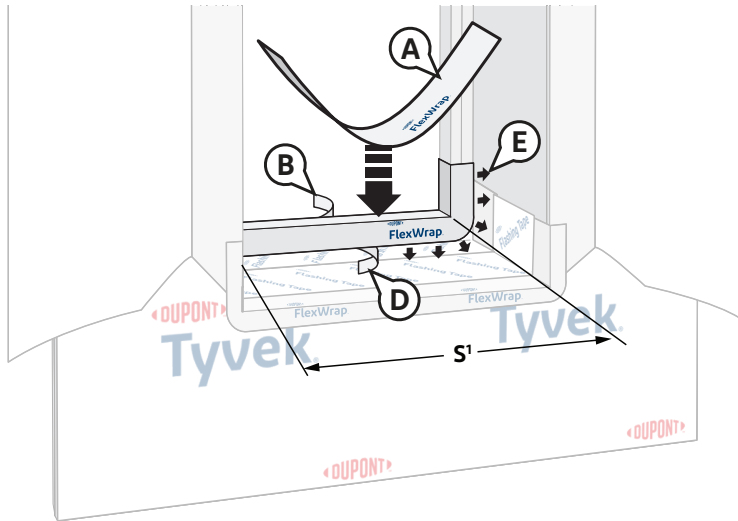

STEP 5

Install DuPont™ FlexWrap™ in Rough Opening at Sill

- Cut **FlexWrap™** at least 12" **LONGER** than width of inner/recessed sill (S). Use roll widths sufficient to achieve a minimum of 1" adhesion **BEYOND** where the window frame will be located, ensuring 2"– 3" adhesion onto the face of the framing.
- Remove wide piece of release paper.
- Position on horizontal surface of inner/recessed sill by aligning the inside edge of the narrow release paper with the face of the framing to ensure 2"– 3" of the **FlexWrap™** will be adhered to the face of the framing. Adhere into rough opening along sill and a minimum of 6" up each jamb.
- Remove narrow release paper.
- Fan out **FlexWrap™** at bottom corners onto face of recessed stud framing. Coverage of **FlexWrap™** should be 2"– 3" onto the face of the stud framing.

NOTE: DuPont™ Tyvek® Certified Installers may install a 3-piece head (and sill) detail for window openings less than 6 ft. wide. For windows greater than 6 ft. wide, see the [Special Considerations](#) section for more information regarding the 3-piece head/sill detail. Contact your local DuPont Building Envelope Specialist for more information about the Certified Installer program.

Installation Methods for DuPont Self-Adhered Flashing Products Installed AFTER the DuPont™ Tyvek® WRB Integral Flanged Window with Deep (Greater than 4") Recessed Opening

Method 1: Depth of Recess Less Than 1/2 the Width of the Recess

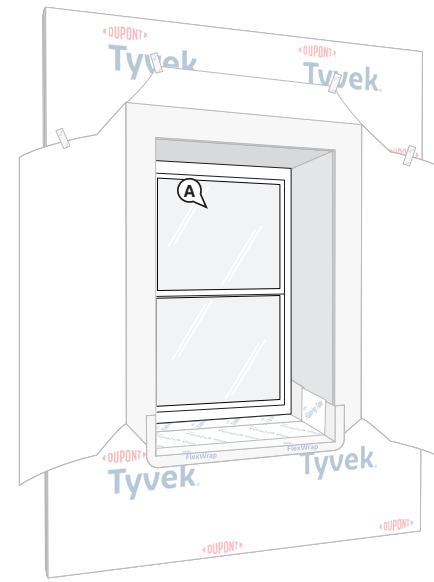
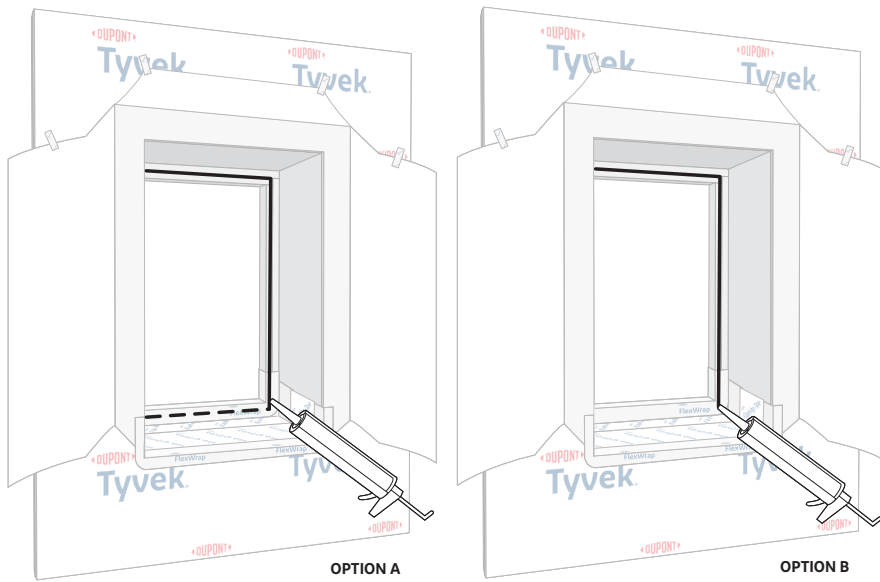

STEP 6

OPTION A: Apply a continuous bead of Tower® Residential Sealant, or recommended sealant, at window head and jambs to wall or back side of window mounting flange. To allow for drainage, do not apply continuous sealant bead along sill. Ensure a minimum 2" wide drainage gap in the sealant bead within 4" from each corner of the jamb-sill interface. Continue applying sealant along the sill with additional 2" wide (min.) drainage gaps for every 6"– 12" (on center) of sill width.

OPTION B: Apply a continuous bead of Tower® Residential Sealant, or recommended sealant, at window head and jambs to wall or back side of window mounting flange. To allow for drainage, do not apply sealant bead along sill.

STEP 7

Install Window

A. Install window per window manufacturer's instructions.

Installation Methods for DuPont Self-Adhered Flashing Products Installed AFTER the DuPont™ Tyvek® WRB Integral Flanged Window with Deep (Greater than 4") Recessed Opening

Method 1: Depth of Recess Less Than 1/2 the Width of the Recess

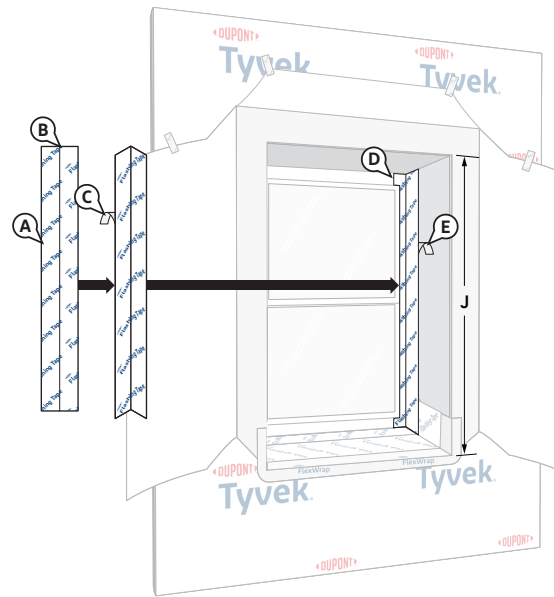

STEP 8

Install* DuPont™ Flashing Tape at Jambs

A. Cut a piece of **DuPont™ Flashing Tape** the length of the outer jamb (J).

NOTE: This dimension will need to be adjusted accordingly to accommodate the slope in the sill. Use appropriate width of **DuPont™ Flashing Tape** to overlap window flange, adhere onto face of stud frame, and extend a minimum of 2" onto jamb wall of recess.

B. Fold lengthwise to create a sharp crease in release paper that is aligned with the intersection of the face of the stud framing and jamb wall of recess.

C. Remove the first piece of release paper to expose the butyl that will be installed onto the window flange by tearing along the crease. **DO NOT CUT** release paper with sharp object as this could result in damage to butyl and compromise protection provided by the **DuPont™ Flashing Tape**.

D. Starting at top corner of recess, adhere exposed butyl adhesive onto window flange and face of stud framing.

E. Remove remaining release paper and adhere exposed butyl onto recess wall plane.

F. Repeat Steps A – E for opposite jamb.

*Use **DuPont Self-Adhered Flashing Products** with a recommended adhesive/primer as applicable to seal directly to exterior gypsum sheathing, concrete, masonry, or other rough surfaces. An adhesive/primer is not required for wood-based sheathing except when applying flashing during adverse weather conditions.

Installation Methods for DuPont Self-Adhered Flashing Products Installed AFTER the DuPont™ Tyvek® WRB Integral Flanged Window with Deep (Greater than 4") Recessed Opening

Method 1: Depth of Recess Less Than 1/2 the Width of the Recess

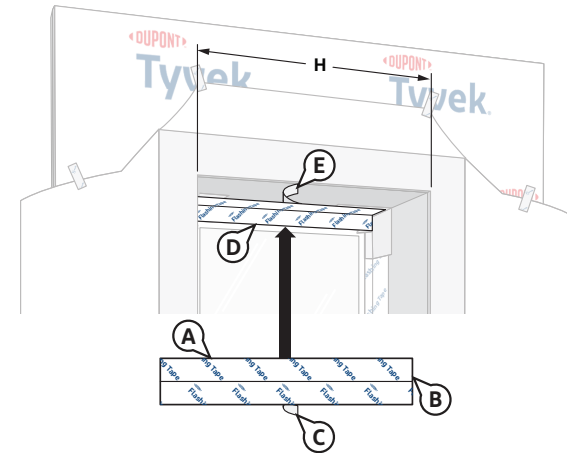
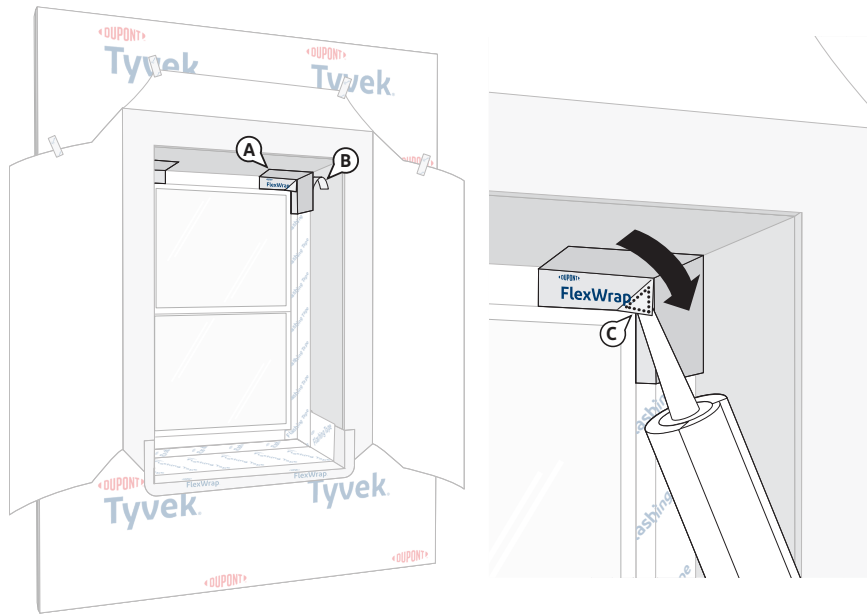

STEP 9

Install* DuPont™ FlexWrap™ Recessed Window Corners at Head

- Install a **FlexWrap™** recessed window corner into the upper corner of the window rough opening with exposed butyl adhered onto the window flanges in a similar manner used for lower corner pieces (See [STEP 2](#)).
- Remove remaining release paper and adhere exposed butyl onto head and jamb walls of recess.
- OPTIONAL:** Apply a bead of Tower® Residential Sealant or recommended sealant inside the corner flap behind the loose triangular flap of the corner piece. Press the loose triangular flap into the sealant in the corner piece.
- Repeat Steps A – C for opposite corner.

STEP 10

Install* DuPont™ Flashing Tape at Head

- Cut a piece of **DuPont™ Flashing Tape** the length of the inner head rough opening "H". Use appropriate width of **DuPont™ Flashing Tape** to overlap window flange, adhere onto face of stud frame, and extend a minimum of 2" onto ceiling of recess.
- Fold lengthwise to create a sharp crease in the release paper that is aligned with the intersection of the face of the stud framing and ceiling of recess.
- Remove release paper by tearing along fold to expose butyl for installation onto the window flange and face of stud framing. **DO NOT CUT** release paper with sharp object as this could result in damage to butyl and compromise protection provided by the **DuPont™ Flashing Tape**.
- Adhere onto window flange and tightly into corner of intersection between face of stud framing and ceiling of recess.
- Remove remaining release paper and adhere onto ceiling of recess.

*Use **DuPont Self-Adhered Flashing Products** with a recommended adhesive/primer as applicable to seal directly to exterior gypsum sheathing, concrete, masonry, or other rough surfaces. An adhesive/primer is not required for wood-based sheathing except when applying flashing during adverse weather conditions.

Installation Methods for DuPont Self-Adhered Flashing Products Installed AFTER the DuPont™ Tyvek® WRB Integral Flanged Window with Deep (Greater than 4") Recessed Opening

Method 1: Depth of Recess Less Than 1/2 the Width of the Recess

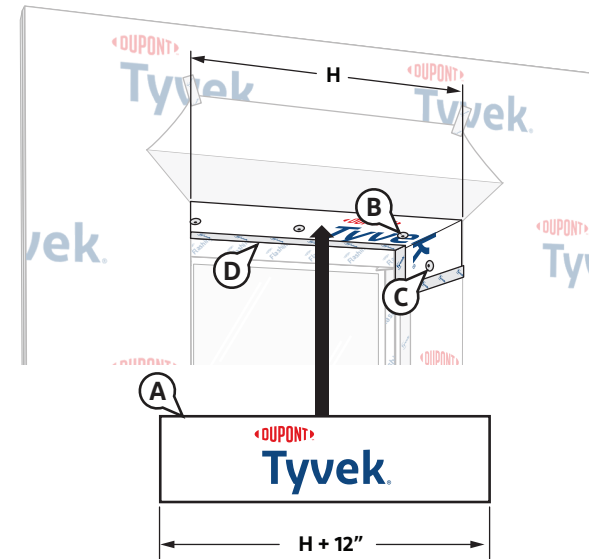
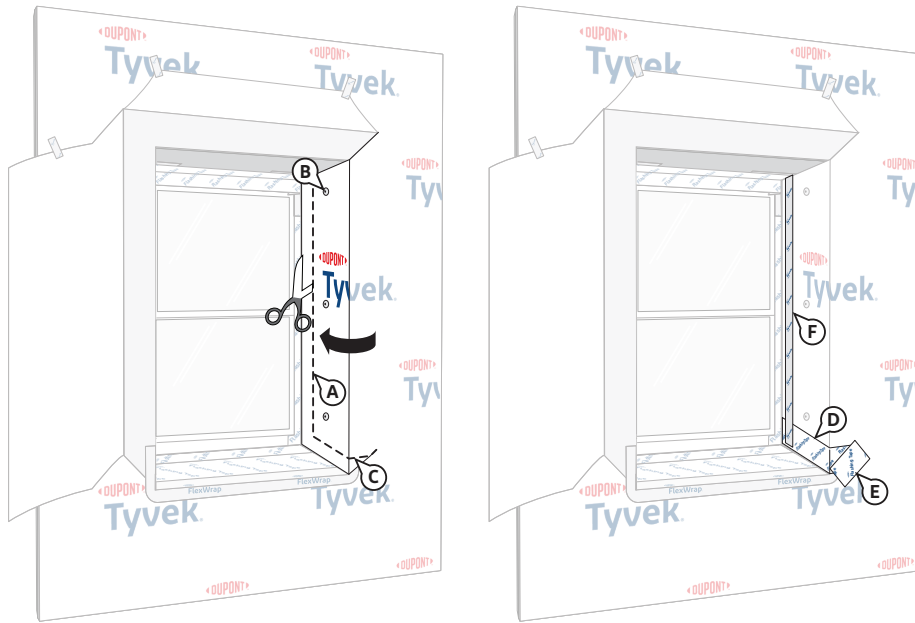

STEP 11

Install Jamb Flaps Into Recess

- Trim bottom and side edges of jamb flap if necessary. Flap should overlap jamb flashing by 2" and to allow for sealing using **DuPont™ Tyvek® Tape** or **DuPont™ Flashing Tape**.
- Fasten the **Tyvek® WRB** to jamb walls of recess. Do not fasten within 3" of vertical and horizontal borders of flap.
- Trim lower edges of jamb flaps to allow sealing at bottom of recess jamb walls.
- Install **DuPont™ Flashing Tape** along the bottom edges of flap inside recess and onto face of wall.
- Install **DuPont™ Flashing Tape** along the bottom angled cuts in the **Tyvek® WRB** making sure to overlap with **DuPont™ Flashing Tape** at lower edges of flaps inside recess.
- Seal vertical edge of flap with **Tyvek® Tape**.
- Repeat Steps A through F for opposite jamb.

STEP 12

Install Tyvek® WRB at Recess Ceiling

- Cut a piece of **Tyvek® WRB** 12" **LONGER** than recess rough opening (H) and width 1–2" less than depth of the recess.
- Fasten at recess ceiling so outer edge is aligned with face of the wall and 6" overlaps onto jamb walls. Do not fasten within 3" of edges so the **Tyvek® WRB** can be sealed to head flashing using **Tyvek® Tape** without fastener interference.
- Fasten at jamb walls of recess. Do not fasten within 3" of edges.
- Seal all inside edges using **Tyvek® Tape** or **DuPont™ Flashing Tape**.

Installation Methods for DuPont Self-Adhered Flashing Products Installed AFTER the DuPont™ Tyvek® WRB Integral Flanged Window with Deep (Greater than 4") Recessed Opening

Method 1: Depth of Recess Less Than 1/2 the Width of the Recess

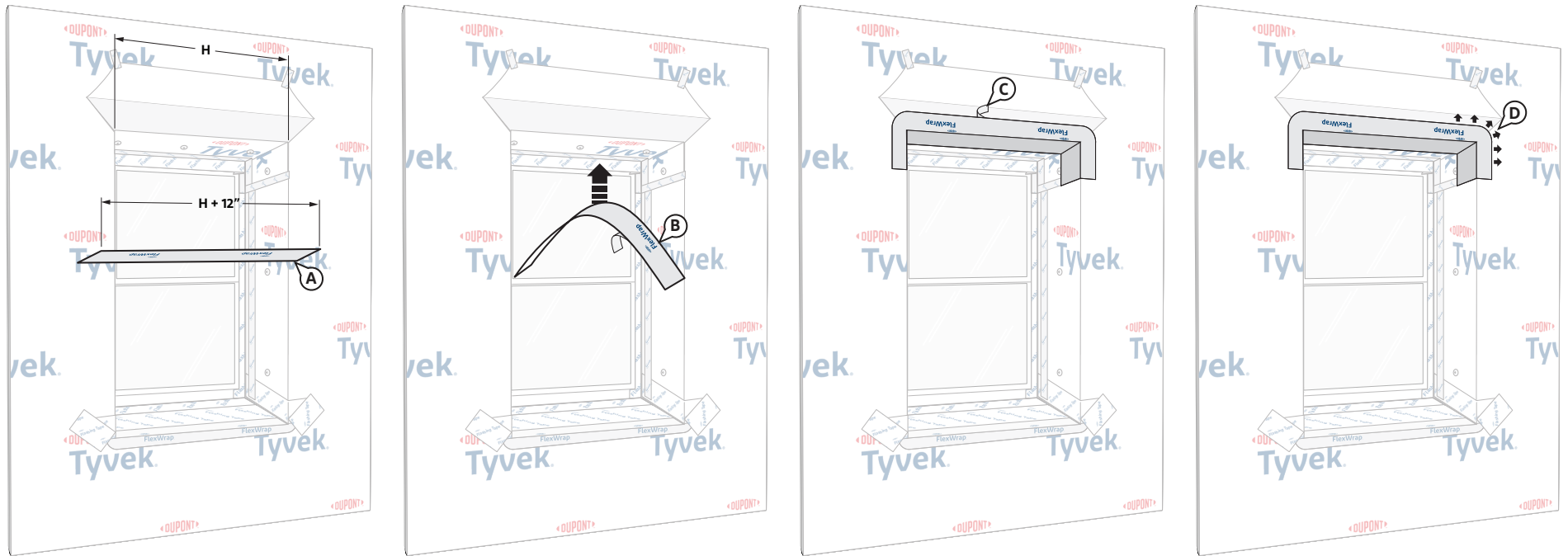

STEP 13

Install* DuPont™ FlexWrap™ in Rough Opening at Head

- Cut **FlexWrap™** at least 12" **LONGER** than width of rough opening head (H). Use roll widths sufficient to achieve a minimum of 2"– 3" adhesion onto the **Tyvek® WRB** patch installed in [STEP 12](#) and the face of the wall.
- Fold the **FlexWrap™** in half lengthwise to create a slight crease at the center. Remove the wide piece of release paper on one side of the fold. Align the inside edge of the narrow release paper with the face of the wall to ensure 2"– 3" of the **FlexWrap™** will be adhered to the face of the wall. Starting at the crease, adhere the **FlexWrap™** at the center of the horizontal portion of the head framing to ensure a minimum of 6" down each jamb. Adhere into rough opening at one corner and down the jamb. Remove the remaining release paper, and repeat at opposite corner.
- Remove narrow release paper.

- Fan out the **FlexWrap™** at corners and adhere onto face of wall. Continue adhering onto face of wall along the head.

NOTE: DuPont™ Tyvek® Certified Installers may install a 3-piece head (and sill) detail for window openings less than 6 ft. wide. For windows greater than 6 ft. wide, see the [Special Considerations](#) section for more information regarding the 3-piece head/sill detail. Contact your local DuPont Building Envelope Specialist for more information about the Certified Installer program.

*Use **DuPont Self-Adhered Flashing Products** with a recommended adhesive/primer as applicable to seal directly to exterior gypsum sheathing, concrete, masonry, or other rough surfaces. An adhesive/primer is not required for wood-based sheathing except when applying flashing during adverse weather conditions.

Installation Methods for DuPont Self-Adhered Flashing Products Installed AFTER the DuPont™ Tyvek® WRB Integral Flanged Window with Deep (Greater than 4") Recessed Opening

Method 1: Depth of Recess Less Than 1/2 the Width of the Recess

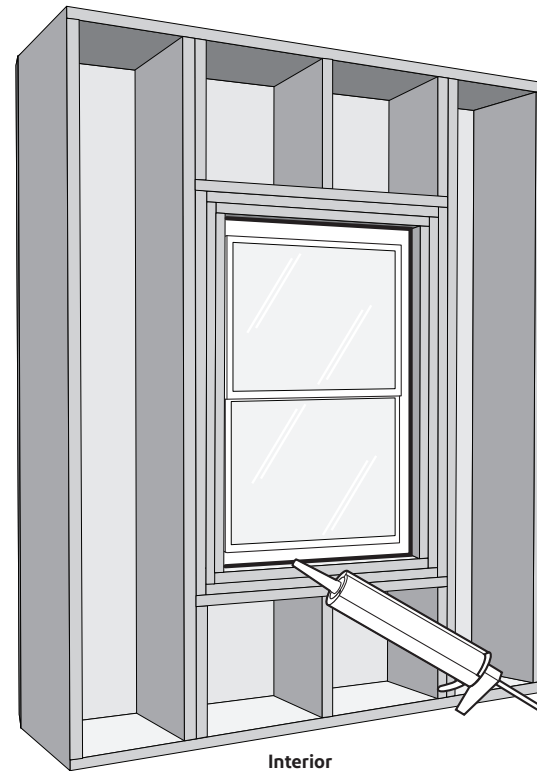
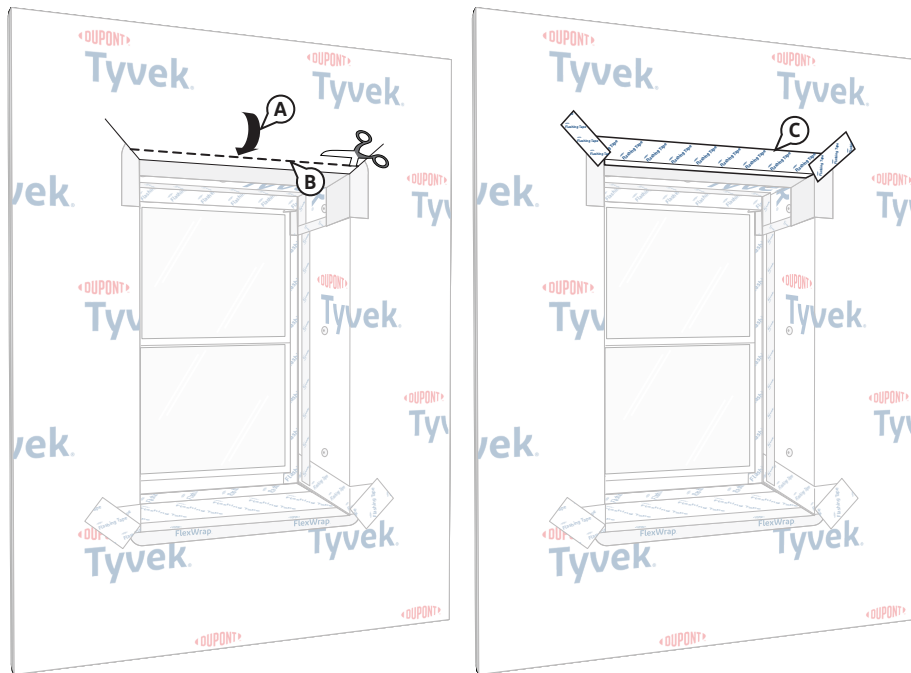

STEP 14

Secure Upper Flap

- Flip down upper flap of **Tyvek® WRB** so it lays flat across **FlexWrap™** at head of outer recess.
- Cut ~1" strip of the **Tyvek® WRB** at lower horizontal edge of head flap. **NOTE:** Skip this step if the head flap was trimmed while preparing the **Tyvek® WRB** per the [Alternative Installation Considerations](#) section.
- Terminate head flap by continuously sealing the horizontal then diagonal seams with **DuPont™ Flashing Tape** or **DuPont™ StraightFlash™**. If additional drainage is desired and **an air barrier is not required**, skip-taping head flap with a maximum of two (2) 2" gaps for every 3' of window is acceptable.

NOTE: Install mechanical fasteners through flashing as needed for increased holding power. See the table in the [Applicable Structures and Performance Criteria](#) section for more information on air barrier requirements and head flap terminations.

STEP 15

Final Step

Apply a continuous bead of Tower® Residential Sealant or recommended sealant (and backer rod as necessary) around the window opening at the interior. It is also acceptable to use **Great Stuff Pro™ Window & Door Polyurethane Foam Sealant**, or recommended foam. When using Tower® Residential Sealant, tool sealant bead flat to allow the natural curing process to create a concave shape. Be sure that the sealant penetrates the grooves of the **DuPont™ FlexWrap™** around the sill. When using **Great Stuff Pro™ Window & Door Polyurethane Foam Sealant** in perimeter openings less than 1/2", apply using the plastic extension tip for the **Great Stuff Pro™ Dispensing Gun** during installation.

Installation Methods for DuPont Self-Adhered Flashing Products Installed AFTER the DuPont™ Tyvek® WRB Integral Flanged Window with Deep (Greater than 4") Recessed Opening

Method 2: Depth of Recess Greater Than 1/2 the Width of the Recess

This method applies to the following products: DuPont™ Flashing Tape, DuPont™ StraightFlash™, and DuPont™ FlexWrap™

This method must be used when the depth of the recess is greater than 1/2 the width of the recess which requires additional strips of Tyvek® WRB to cover jamb walls of the recess. If the depth of the recess is less than 1/2 the width of the recess, Method 2 may also be used in place of Method 1 when the depth of the recess is less than 1/2 the width of the recess.

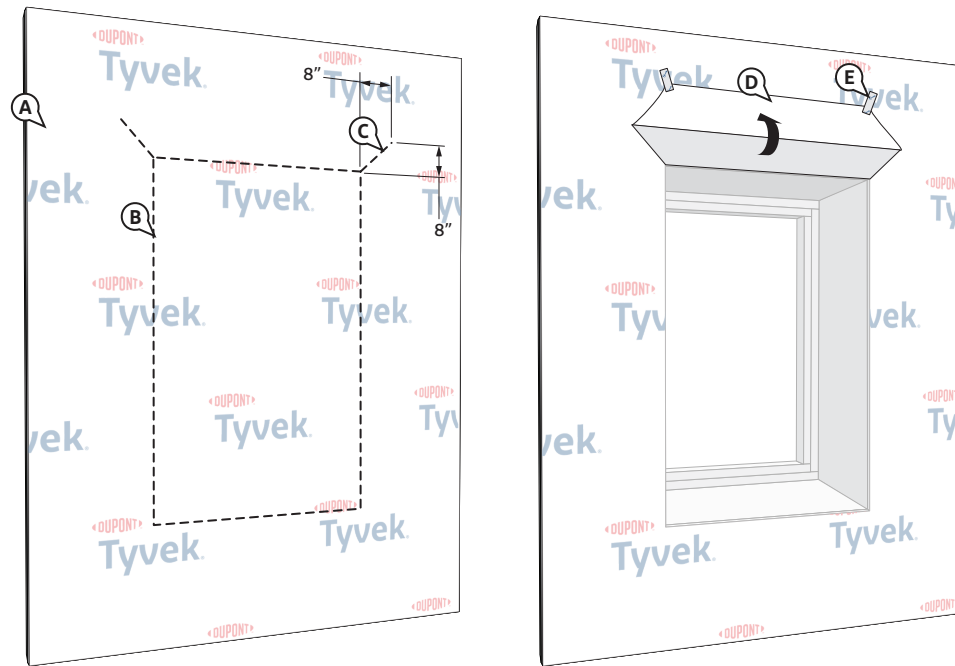

STEP 1

Prepare Tyvek® WRB Frame for Window Installation

OPTIONAL: Refer to the [Alternative Installation Considerations](#) section for guidance regarding trimming the head flap while preparing the Tyvek® WRB if desired instead.

- Wrap wall as shown in the applicable Tyvek® WRB Installation Guideline that can be found at building.dupont.com. Do not install fasteners within 6" of the sills and jambs of the openings and within 9" of the head of the openings.
- Make a cut in the Tyvek® WRB along the perimeter of the rough opening. Ensure that the Tyvek® WRB is cut flush with the sheathing and is not wrapped into the rough opening.

- Cut two 45 degree slits extending a minimum of 8" up and away from the top corners of the rough opening. This will create a flap to expose sheathing or framing members to allow head flashing installation.
- Flip the head flap up to expose the sheathing and temporarily secure with DuPont™ Tyvek® Tape.

Alternative Method to Secure Head Flap: In lieu of temporarily taping, the head flap can be tucked under the Tyvek® WRB.

- Temporarily secure the Tyvek® WRB frame with Tyvek® Tape around rough opening before flashing is installed to help facilitate flashing installation.

Installation Methods for DuPont Self-Adhered Flashing Products Installed AFTER the DuPont™ Tyvek® WRB

Integral Flanged Window with Deep (Greater than 4") Recessed Opening

Method 2: Depth of Recess Greater Than 1/2 the Width of the Recess

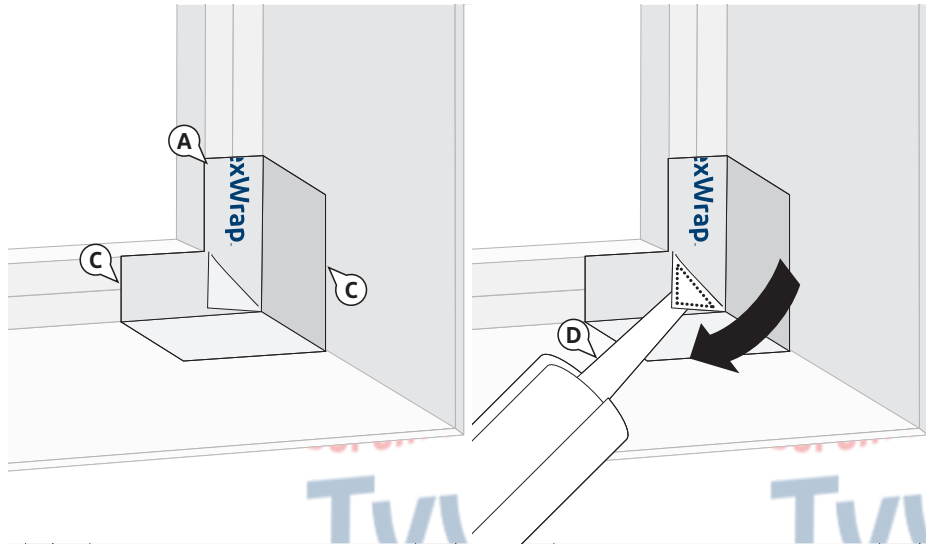

STEP 2

Install* DuPont™ FlexWrap™ Recessed Window Corner at Sill

A. Place **FlexWrap™** recessed window corner into corner of recess so exposed butyl is against face of recessed window frame and adhere.

NOTE: For double stud window frames, the **FlexWrap™** recessed window corner should extend a minimum of 2" onto the face of the stud framing and cover the seams between the studs. For single stud window frames, the **FlexWrap™** recessed window corner extending slightly beyond the face of the stud can be fully adhered onto framing.

B. Remove remaining release paper.

C. Adhere exposed butyl to sill and jamb surfaces of recess.

D. **OPTIONAL:** Apply a bead of Tower® Residential Sealant or recommended sealant behind the loose triangular flap within the **FlexWrap™** recessed window corner. Press down the loose triangular flap onto the sealant.

E. Repeat Steps A – D for opposite side.

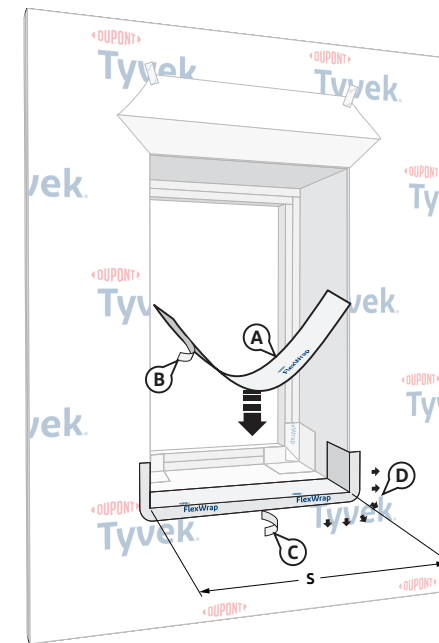

STEP 3

Install* FlexWrap™ at Outer Sill of Recessed Opening

A. Cut **FlexWrap™** at least 12" **LONGER** than width of outer sill of recess (S).

B. Remove wide piece of release paper. Position on horizontal surface of outer sill by aligning the inside edge of the narrow release paper with the face of the wall to ensure 2"–3" of the **FlexWrap™** will be adhered to the face of the wall with a minimum of 6" up each jamb. Adhere onto horizontal surface.

C. Remove narrow release paper.

D. Fan out **FlexWrap™** at bottom corners onto face of wall. Continue adhering onto face of wall along sill. Coverage of **FlexWrap™** should be 2"–3" onto the face of the wall.

NOTE: DuPont™ Tyvek® Certified Installers may install a 3-piece head (and sill) detail for window openings less than 6 ft. wide. For windows greater than 6 ft. wide, see the [Special Considerations](#) section for more information regarding the 3-piece head/sill detail. Contact your local DuPont Building Envelope Specialist for more information about the Certified Installer program.

*Use DuPont Self-Adhered Flashing Products with a recommended adhesive/primer as applicable to seal directly to exterior gypsum sheathing, concrete, masonry, or other rough surfaces. An adhesive/primer is not required for wood-based sheathing except when applying flashing during adverse weather conditions.

Installation Methods for DuPont Self-Adhered Flashing Products Installed AFTER the DuPont™ Tyvek® WRB Integral Flanged Window with Deep (Greater than 4") Recessed Opening

Method 2: Depth of Recess Greater Than 1/2 the Width of the Recess

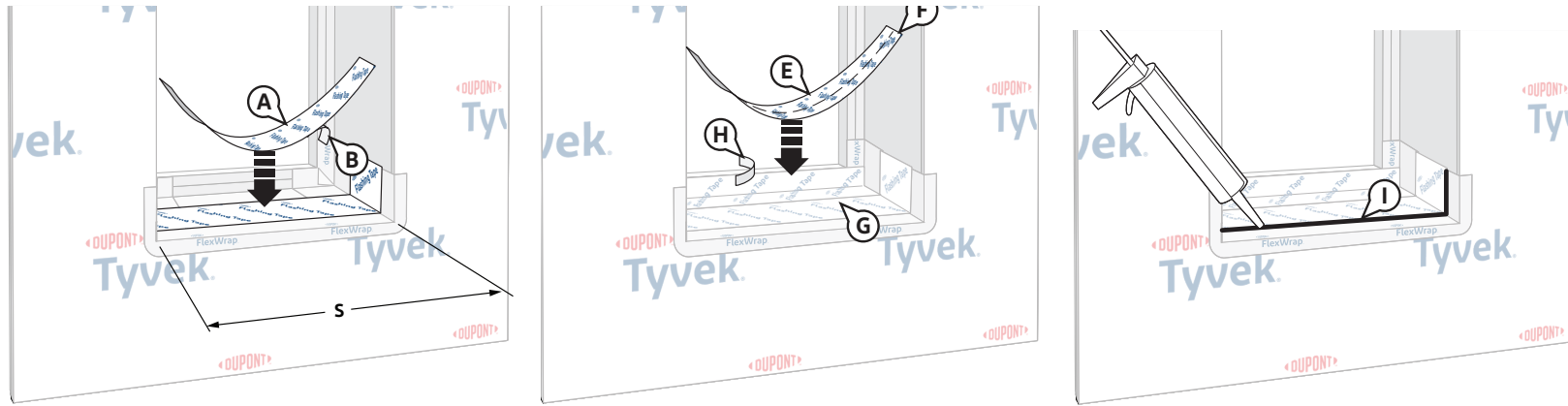

STEP 4

Install* DuPont™ Flashing Tape at Sill of Recess

DuPont™ Flashing Tape will be used at the sill of the recess in this Step to overlap the **DuPont™ FlexWrap™** at the outer sill and extend onto the face of the stud framing at the inner window sill. The number of layers and product widths can be modified accordingly but all overlaps need to be a minimum of 2". All but the last layer of **DuPont™ Flashing Tape** will extend 6" min. up each side of the recess jamb walls. The last layer will be the width of the outer rough opening and will extend 2" min. onto the face of the stud framing at the sill of the window.

- A. Cut the first course of **DuPont™ Flashing Tape** 12" **LONGER** than outer sill (S).
- B. Remove the release paper and align on sill to overlap **FlexWrap™** by 2" and extend up each jamb wall of recess by 6". **DuPont™ Flashing Tape** should be installed tightly into the corner at the intersection of the recess sill and wall of recess.
NOTE: The **DuPont™ Flashing Tape** on the jamb walls will have an angled offset from the window framing in recesses that have a sloped sill.
- C. Adhere exposed butyl to sill and up jamb walls of recess.
- D. If necessary, repeat Step B with appropriate width of **DuPont™ Flashing Tape** to overlap the first layer of **DuPont™ Flashing Tape** by 2".

- E. Cut the last layer of **DuPont™ Flashing Tape** the length of the inner window sill (S), and use appropriate width for a minimum of 2" adhesion of butyl onto the face of the stud framing at the window sill maintaining a 2" overlap onto previous layer.
NOTE: This dimension will need to be adjusted if the side walls of the recess are tapered.
- F. Fold to create a sharp crease that is aligned with the intersection of the recessed sill and the face of the stud framing. Tear release paper at the fold so exposed butyl can be adhered onto sill of recess. **DO NOT CUT** release paper with sharp object as this may damage the butyl and compromise protection provided by the **DuPont™ Flashing Tape**.
- G. Adhere exposed butyl on sill of recess and tight into the intersection of recessed sill and face of stud framing.
- H. Remove second release paper and adhere exposed butyl onto face of stud framing.
- I. Apply a continuous bead of Tower® Residential Sealant or recommended sealant along the face of the overlap between the **DuPont™ Flashing Tape** and the **FlexWrap™**.

*Use **DuPont Self-Adhered Flashing Products** with a recommended adhesive/primer as applicable to seal directly to exterior gypsum sheathing, concrete, masonry, or other rough surfaces. An adhesive/primer is not required for wood-based sheathing except when applying flashing during adverse weather conditions.

Installation Methods for DuPont Self-Adhered Flashing Products Installed AFTER the DuPont™ Tyvek® WRB Integral Flanged Window with Deep (Greater than 4") Recessed Opening

Method 2: Depth of Recess Greater Than 1/2 the Width of the Recess

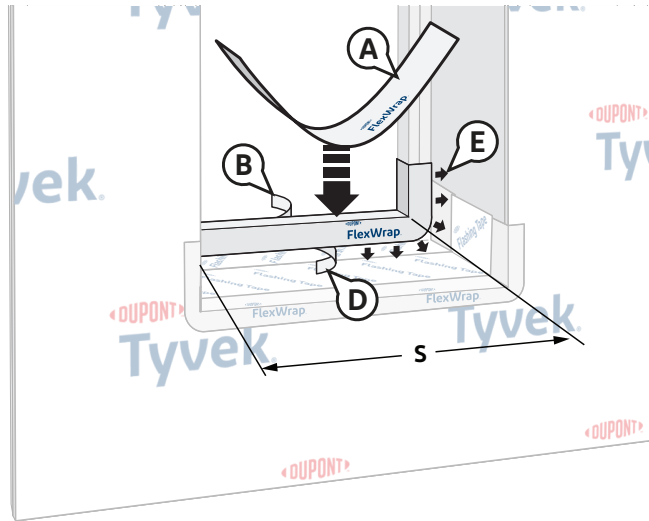

STEP 5

Install DuPont™ FlexWrap™ in Rough Opening at Sill

- A. Cut **FlexWrap™** at least 12" **LONGER** than width of inner/recessed sill(S). Use roll widths sufficient to achieve a minimum of 1" adhesion **BEYOND** where the window frame will be located, ensuring 2"- 3" adhesion onto the face of the framing.
- B. Remove wide piece of release paper.
- C. Position on horizontal surface of inner/recessed sill by aligning the inside edge of the narrow release paper with the face of the framing to ensure 2"- 3" of the **FlexWrap™** will be adhered to the face of the framing. Adhere into rough opening along sill and a minimum of 6" up each jamb.
- D. Remove narrow release paper.
- E. Fan out **FlexWrap™** at bottom corners onto face of recessed stud framing. Coverage of **FlexWrap™** should be 2"- 3" onto the face of the stud framing.

NOTE: DuPont™ Tyvek® Certified Installers may install a 3-piece™ head (and sill) detail for window openings less than 6 ft. wide. For windows greater than 6 ft. wide, see the [Special Considerations](#) section for more information regarding the 3-piece head/sill detail. Contact your local DuPont Building Envelope Specialist for more information about the Certified Installer program.

Installation Methods for DuPont Self-Adhered Flashing Products Installed AFTER the DuPont™ Tyvek® WRB Integral Flanged Window with Deep (Greater than 4") Recessed Opening

Method 2: Depth of Recess Greater Than 1/2 the Width of the Recess

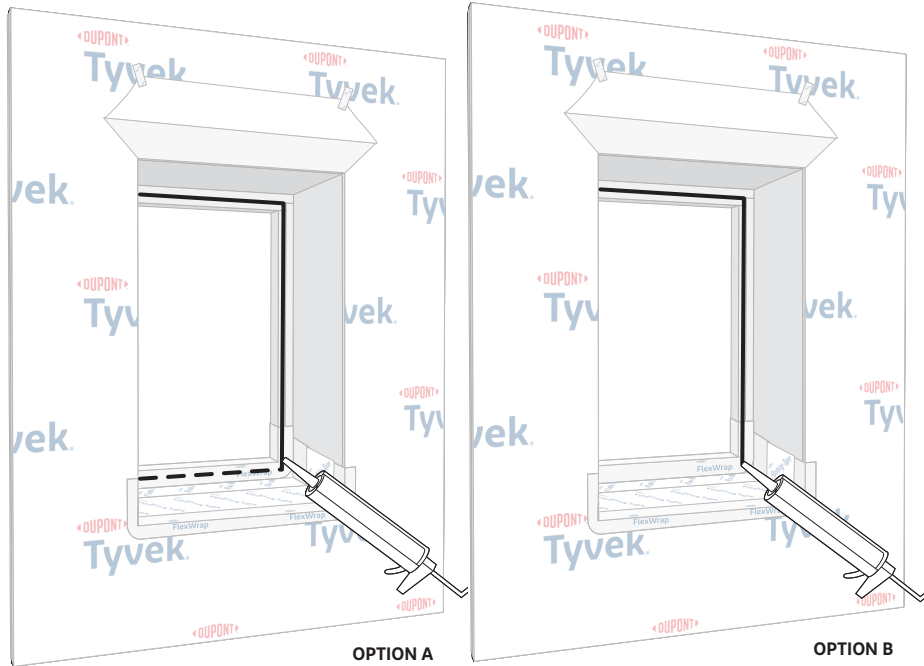

STEP 6

OPTION A: Apply a continuous bead of Tower® Residential Sealant, or recommended sealant, at window head and jambs to wall or back side of window mounting flange. To allow for drainage, do not apply continuous sealant bead along sill. Ensure a minimum 2" wide drainage gap in the sealant bead within 4" from each corner of the jamb-sill interface. Continue applying sealant along the sill with additional 2" wide (min.) drainage gaps for every 6"– 12" (on center) of sill width.

OPTION B: Apply a continuous bead of Tower® Residential Sealant, or recommended sealant, at window head and jambs to wall or back side of window mounting flange. To allow for drainage, do not apply sealant bead along sill.

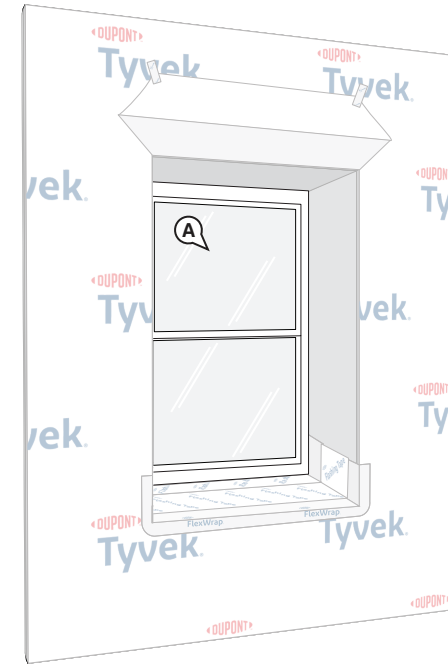

STEP 7

Install Window

A. Install window per window manufacturer's instructions.

Installation Methods for DuPont Self-Adhered Flashing Products Installed AFTER the DuPont™ Tyvek® WRB Integral Flanged Window with Deep (Greater than 4") Recessed Opening

Method 2: Depth of Recess Greater Than 1/2 the Width of the Recess

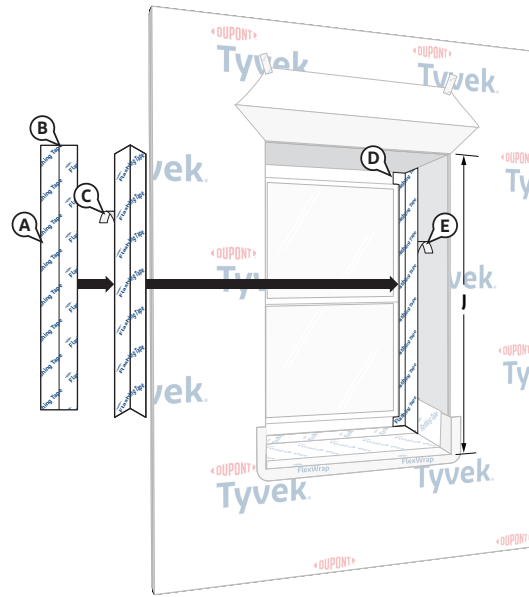

STEP 8

Install* DuPont™ Flashing Tape at Jambs

A. Cut a piece of **DuPont™ Flashing Tape** 2" **LONGER** than the length of the outer jamb (J).

NOTE: This dimension will need to be adjusted accordingly to accommodate the slope in the sill. Use appropriate width of **DuPont™ Flashing Tape** to overlap window flange, adhere onto face of stud frame, and extend a minimum of 2" onto jamb wall of recess.

B. Fold lengthwise to create a sharp crease in release paper that is aligned with the intersection of the face of the stud framing and jamb wall of recess.

C. Remove the first piece of release paper to expose the butyl that will be installed onto the window flange by tearing along the crease. **DO NOT CUT** release paper with sharp object as this could result in damage to butyl and compromise protection provided by the **DuPont™ Flashing Tape**.

D. Starting at top corner of recess, adhere exposed butyl adhesive onto window flange and face of stud framing.

E. Remove remaining release paper and adhere exposed butyl onto recess wall plane.

F. Repeat Steps A – E for opposite jamb.

*Use **DuPont Self-Adhered Flashing Products** with a recommended adhesive/primer as applicable to seal directly to exterior gypsum sheathing, concrete, masonry, or other rough surfaces. An adhesive/primer is not required for wood-based sheathing except when applying flashing during adverse weather conditions.

Installation Methods for DuPont Self-Adhered Flashing Products Installed AFTER the DuPont™ Tyvek® WRB Integral Flanged Window with Deep (Greater than 4") Recessed Opening

Method 2: Depth of Recess Greater Than 1/2 the Width of the Recess

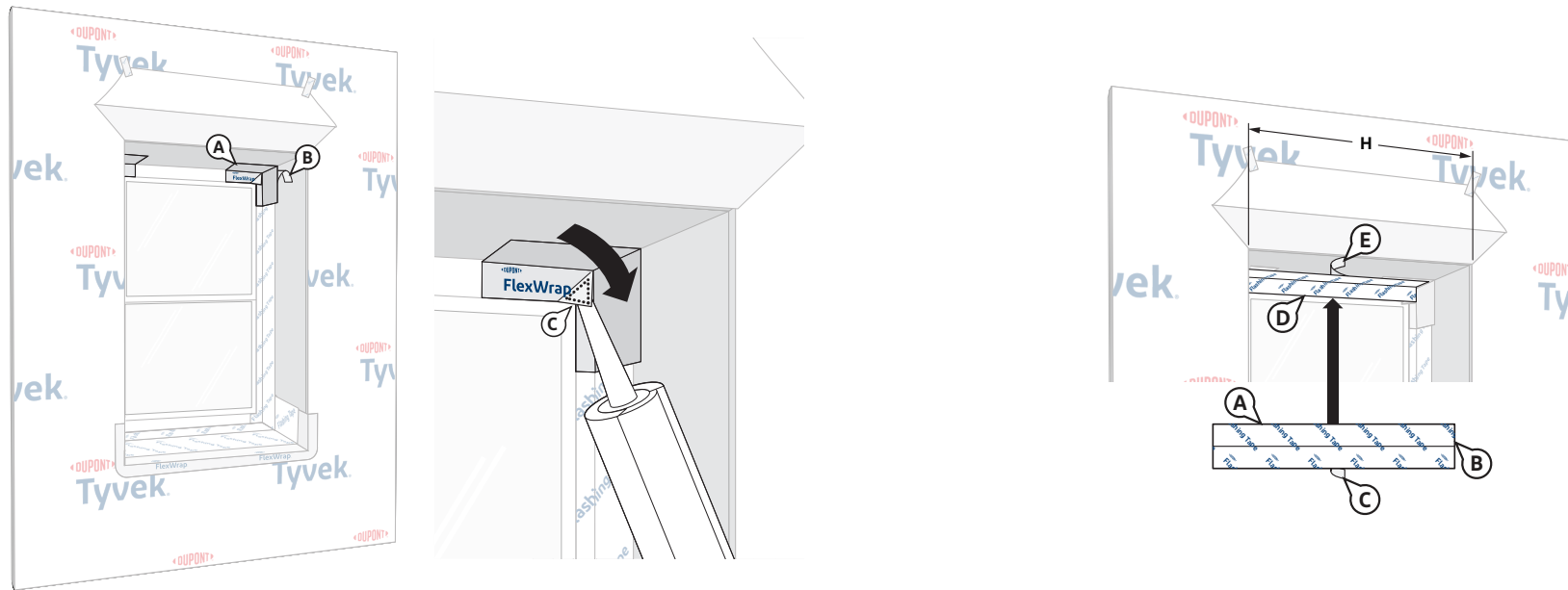

STEP 9

Install DuPont™ FlexWrap™ Recessed Window Corners at Head

- Install a **FlexWrap™** recessed window corner into the upper corner of the window rough opening with exposed butyl adhered onto the window flanges in a similar manner used for lower corner pieces (See Step 3).
- Remove remaining release paper and adhere* exposed butyl onto head and jamb walls of recess.
- OPTIONAL:** Apply a bead of Tower® Residential Sealant or recommended sealant inside the corner flap behind the loose triangular flap of the corner piece. Press the loose triangular flap into the sealant in the corner piece.
- Repeat Steps A – C for opposite corner.

STEP 10

Install* DuPont™ Flashing Tape at Head

- Cut a piece of **DuPont™ Flashing Tape** the length of the head rough opening "H". Use appropriate width of **DuPont™ Flashing Tape** to overlap window flange, adhere onto face of stud frame, and extend a minimum of 2" onto ceiling of recess.
- Fold lengthwise to create a sharp crease in the release paper that is aligned with the intersection of the face of the stud framing and ceiling of recess.
- Remove release paper by tearing along fold to expose butyl for installation onto the window flange and face of stud framing. **DO NOT CUT** release paper with sharp object as this could result in damage to butyl and compromise protection provided by the **DuPont™ Flashing Tape**.
- Adhere onto window flange and tightly into corner of intersection between face of stud framing and ceiling of recess.
- Remove remaining release paper and adhere onto ceiling of recess.

*Use **DuPont Self-Adhered Flashing Products** with a recommended adhesive/primer as applicable to seal directly to exterior gypsum sheathing, concrete, masonry, or other rough surfaces. An adhesive/primer is not required for wood-based sheathing except when applying flashing during adverse weather conditions.

Installation Methods for DuPont Self-Adhered Flashing Products Installed AFTER the DuPont™ Tyvek® WRB Integral Flanged Window with Deep (Greater than 4") Recessed Opening

Method 2: Depth of Recess Greater Than 1/2 the Width of the Recess

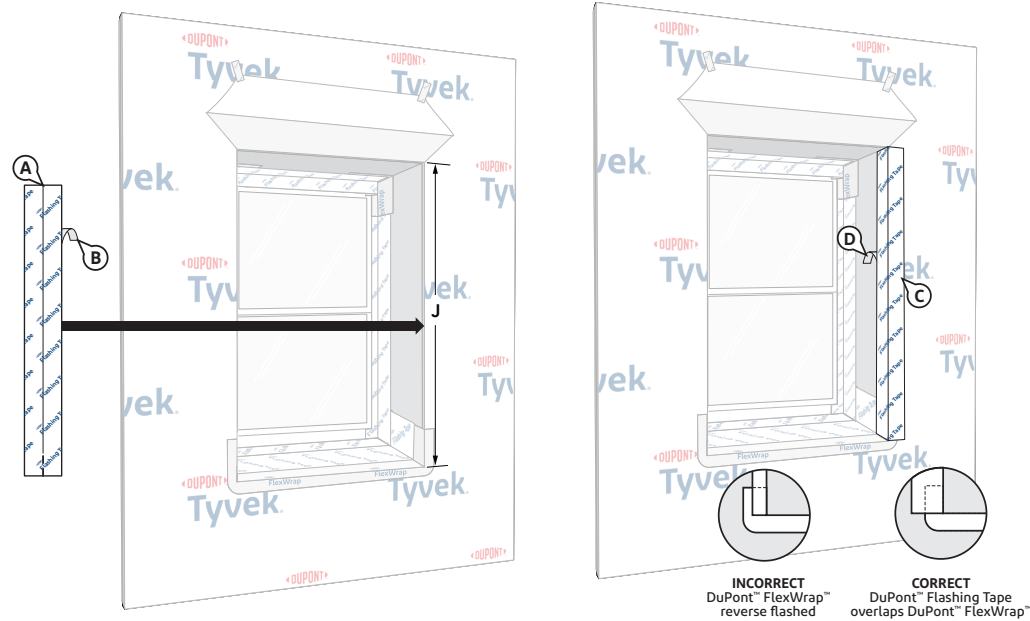

STEP 11

Install* DuPont™ Flashing Tape at Outer Recess Jamb

A. Cut a piece of **DuPont™ Flashing Tape** the length of the jamb rough opening (J) and fold lengthwise creating a sharp crease in the release paper.

Remove one piece of release paper by tearing along the crease, but **DO NOT CUT** release paper with sharp object as this could result in damage to butyl and compromise protection provided by the **DuPont™ Flashing Tape**.

B. Adhere exposed butyl onto face of wall so crease is aligned with edge of outer recess rough opening.

C. Remove remaining release paper and adhere exposed butyl into rough opening of recess.

D. Repeat Steps A – D on opposite side.

*Use **DuPont Self-Adhered Flashing Products** with a recommended adhesive/primer as applicable to seal directly to exterior gypsum sheathing, concrete, masonry, or other rough surfaces. An adhesive/primer is not required for wood-based sheathing except when applying flashing during adverse weather conditions.

Installation Methods for DuPont Self-Adhered Flashing Products Installed AFTER the DuPont™ Tyvek® WRB Integral Flanged Window with Deep (Greater than 4") Recessed Opening

Method 2: Depth of Recess Greater Than 1/2 the Width of the Recess

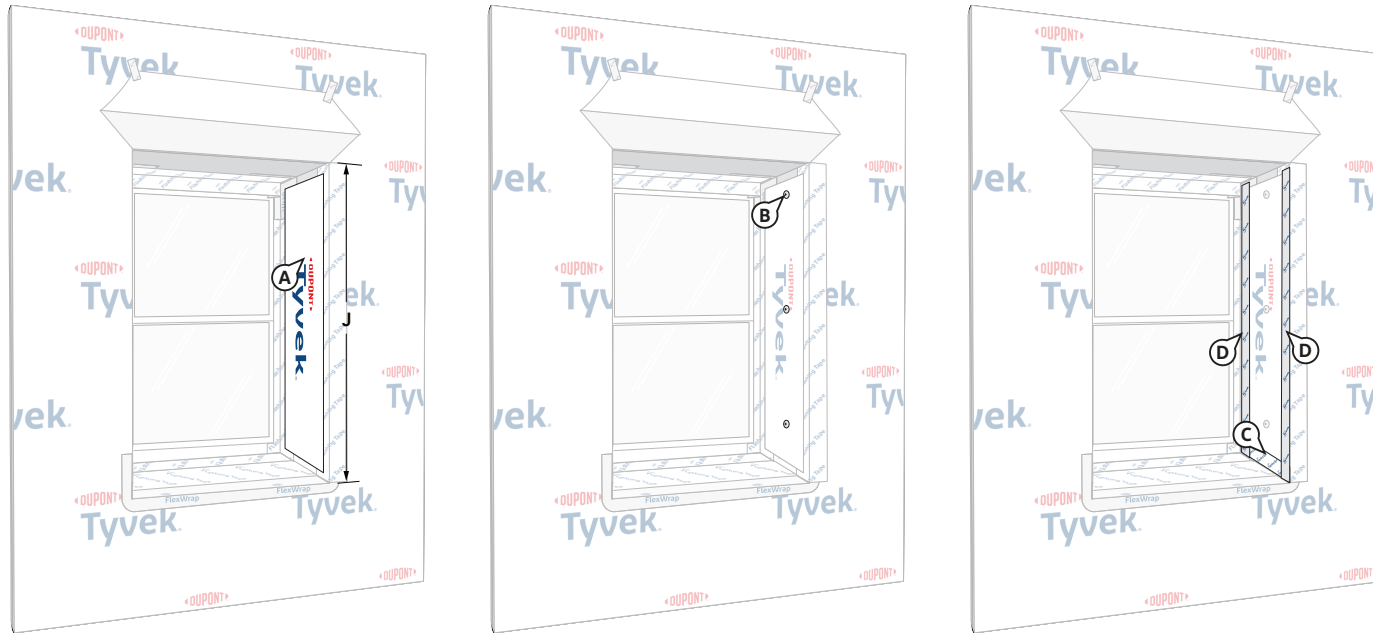

STEP 12

Install DuPont™ Tyvek® to Jamb Walls of Recess

- A. Cut a piece of **Tyvek® WRB** for each recess jamb that is 2" less than the height (J) and 2–4" less than the depth of the rough opening.

NOTE: These dimensions will need to be adjusted accordingly to accommodate the slope of the recess sill.

- B. Align one piece of **Tyvek® WRB** with top of recess and centered on the vertical wall. Do not fasten within 3" of vertical and horizontal edges so the **Tyvek® WRB** patch can be sealed to flashing using **DuPont™ Tyvek® Tape** without fastener interference.

- C. Install **DuPont™ Flashing Tape** along the bottom of the **Tyvek® WRB** inside recess.
D. Seal the vertical edges of the **Tyvek® WRB** using **Tyvek® Tape** or **DuPont™ Flashing Tape**.
E. Repeat on opposite side.

Installation Methods for DuPont Self-Adhered Flashing Products Installed AFTER the DuPont™ Tyvek® WRB Integral Flanged Window with Deep (Greater than 4") Recessed Opening

Method 2: Depth of Recess Greater Than 1/2 the Width of the Recess

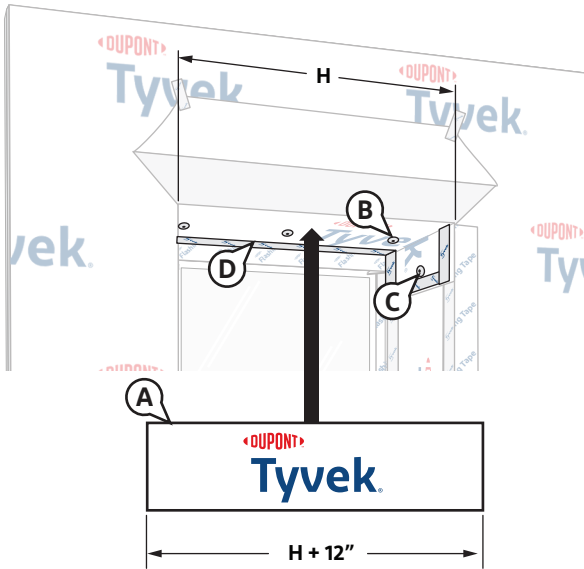

STEP 13

Install Tyvek® WRB Patch at Recess Ceiling

- Cut a piece of **Tyvek® WRB** 12" **LONGER** than the recess rough opening (H) and a width that is 1-2" less than depth of the recess.
- Fasten at recess ceiling so the outer edge is aligned with the face of the wall with a 6" overlap onto each jamb wall. Do not fasten within 3" of edges, so that the piece of **Tyvek® WRB** can be sealed to flashing using **DuPont™ Tyvek® Tape** without fastener interference.
- Seal all inside edges using **Tyvek® Tape**.

Installation Methods for DuPont Self-Adhered Flashing Products Installed AFTER the DuPont™ Tyvek® WRB Integral Flanged Window with Deep (Greater than 4") Recessed Opening

Method 2: Depth of Recess Greater Than 1/2 the Width of the Recess

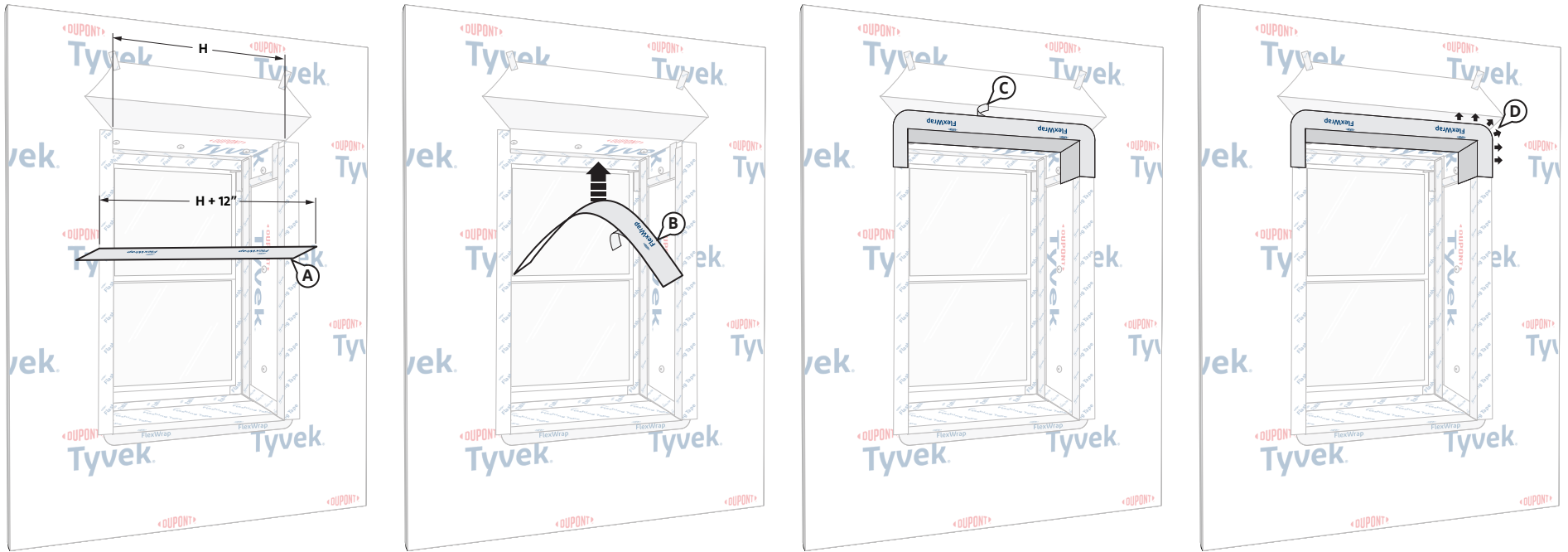

STEP 14

Install* DuPont™ FlexWrap™ Head of Outer Recess

- Cut **FlexWrap™** at least 12" **LONGER** than width of rough opening head (H). Use roll widths sufficient to achieve a minimum of 2"– 3" adhesion onto the **Tyvek® WRB** patch installed in [STEP 13](#) and the face of the wall.
- Fold the **FlexWrap™** in half lengthwise to create a slight crease at the center. Remove the wide piece of release paper on one side of the fold. Align the inside edge of the narrow release paper with the face of the wall to ensure 2"– 3" of the **FlexWrap™** will be adhered to the face of the wall. Starting at the crease, adhere the **FlexWrap™** at the center of the horizontal portion of the head framing to ensure a minimum of 6" down each jamb. Adhere into rough opening at one corner and down the jamb. Remove the remaining release paper, and repeat at opposite corner.
- Remove narrow release paper.

- Fan out the **FlexWrap™** at corners and adhere onto face of wall. Continue adhering onto face of wall along the head.

NOTE: DuPont™ Tyvek® Certified Installers may install a 3-piece head (and sill) detail for window openings less than 6 ft. wide. For windows greater than 6 ft. wide, see the [Special Considerations](#) section for more information regarding the 3-piece head/sill detail. Contact your local DuPont Building Envelope Specialist for more information about the Certified Installer program.

*Use **DuPont Self-Adhered Flashing Products** with a recommended adhesive/primer as applicable to seal directly to exterior gypsum sheathing, concrete, masonry, or other rough surfaces. An adhesive/primer is not required for wood-based sheathing except when applying flashing during adverse weather conditions.

Installation Methods for DuPont Self-Adhered Flashing Products Installed AFTER the DuPont™ Tyvek® WRB Integral Flanged Window with Deep (Greater than 4") Recessed Opening

Method 2: Depth of Recess Greater Than 1/2 the Width of the Recess

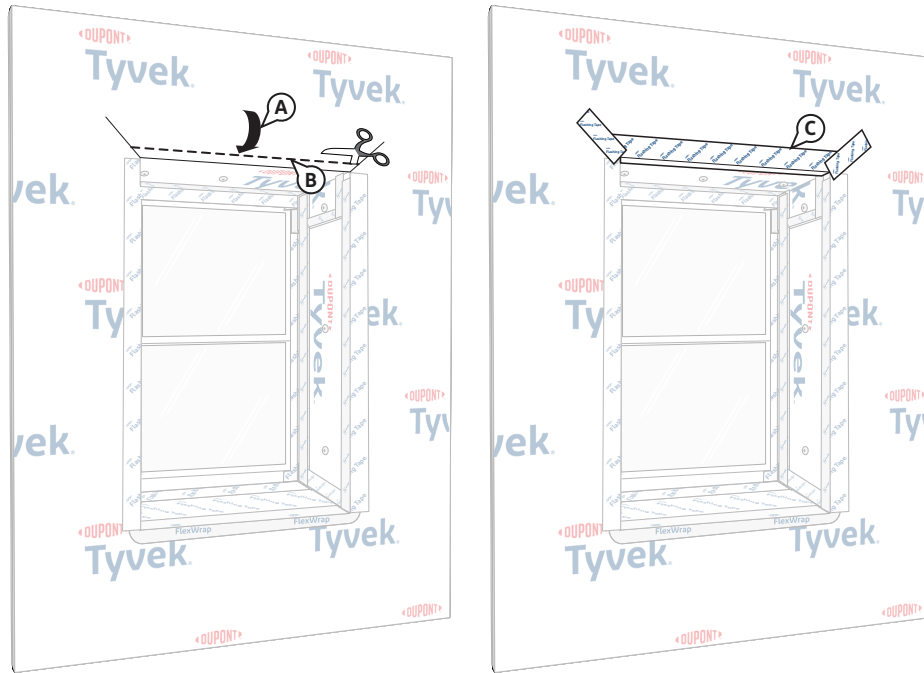

STEP 15

Secure Upper Flap

- Flip down upper flap of the **Tyvek® WRB** so it lays flat across **DuPont™ FlexWrap™** at head of outer recess.
- Cut ~1" strip of the **Tyvek® WRB** at lower horizontal edge of head flap. **NOTE:** Skip this step if the head flap was trimmed while preparing the **Tyvek® WRB** per the [Alternative Installation Considerations](#) section.
- Terminate head flap by continuously sealing the horizontal then diagonal seams with **DuPont™ Flashing Tape** or **DuPont™ StraightFlash™**. If additional drainage is desired and **an air barrier is not required**, skip-taping head flap with a maximum of two (2) 2" gaps for every 3' of window is acceptable.
-

NOTE: Install mechanical fasteners through flashing as needed for increased holding

power. See the table in the [Applicable Structures and Performance Criteria](#) section for more information on air barrier requirements and head flap terminations..

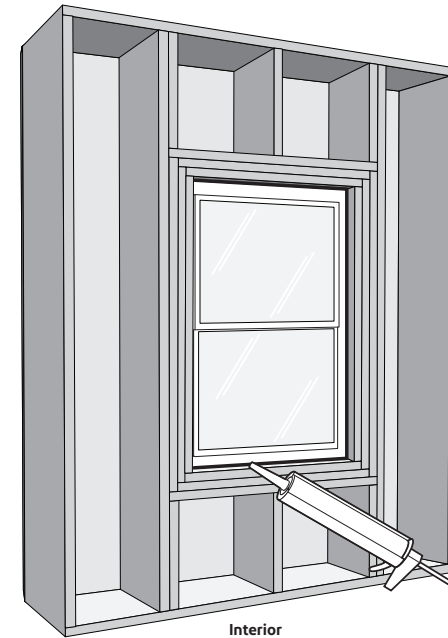

STEP 16

Final Step

Apply a continuous bead of Tower® Residential Sealant or recommended sealant (and backer rod as necessary) around the window opening at the interior. It is also acceptable to use **DuPont™ Window & Door Foam**, **Great Stuff Pro™ Window & Door Polyurethane Foam Sealant**, or recommended foam. When using Tower® Residential Sealant, tool sealant bead flat to allow the natural curing process to create a concave shape. Be sure that the sealant penetrates the grooves of the **FlexWrap™** around the sill. When using **Great Stuff Pro™ Window & Door Polyurethane Foam Sealant** in perimeter openings less than 1/2", apply using the plastic extension tip for the **Great Suff Pro™** Dispensing Gun during installation.

Product Composition and UV Stability

DuPont™ Tyvek® WRBs used in construction products are made from 100% flash spunbonded high density polyethylene fibers which have been bonded together by heat and pressure, without binders or fillers, into a tough durable sheet structure. Additives have been incorporated into the polyethylene to provide ultraviolet light resistance. DuPont requires that **DuPont™ Tyvek® HomeWrap®, Tyvek® DrainWrap™**, and **Tyvek® StuccoWrap®** be covered within 4 months (120 days) of installation. DuPont requires that **DuPont™ Tyvek® CommercialWrap®** and **Tyvek® CommercialWrap® D** be covered within 9 months (270 days) of installation.

DuPont Self-Adhered Flashing Products are made from a synthetic rubber adhesive, and a top sheet of flash spunbonded high density polyethylene fibers or polypropylene film. Additives have been incorporated into these materials to provide ultraviolet light resistance. DuPont requires that **DuPont™ FlexWrap™**, **DuPont™ FlexWrap™ EZ**, and **DuPont™ StraightFlash™** be covered within nine months (270 days) of installation. DuPont requires that **DuPont™ Flashing Tape** be covered within 4 months (120 days) of installation.

DuPont™ Tyvek® Fluid Applied Products are formulated to include elastomeric polymers that cure to a continuous, fully-adhered, tough, durable membrane. Additives have been incorporated to provide ultraviolet light resistance. DuPont requires that the **DuPont™ Tyvek® Fluid Applied WB+™** and **DuPont™ Tyvek® Fluid Applied Flashing and Joint Compound+** are to be covered within 9 months (270 days) of installation.

Design Considerations

When installed in conjunction with other building materials, **Tyvek® WRBs**, **DuPont Self-Adhered Flashing Products**, and **Tyvek® Fluid Applied Products** must be properly shingled with these materials such that water is diverted to the exterior of the wall system. **Tyvek® WRBs** and **Tyvek® Fluid Applied WB+™** are secondary weather barriers. The outer facade is the primary barrier. Follow facade manufacturer's installation and maintenance requirements for all facade systems in order to maintain water holdout properties and ensure performance of **Tyvek® WRBs** and **Tyvek® Fluid Applied WB+™**. Do not install on a wall that does not feature a continuous path for moisture drainage. Any standing water must be allowed to drain off the membrane.

Use of additives, coatings or cleansers on or in the facade system may impact the performance of **DuPont™ Tyvek® WRBs** and **Tyvek® Fluid Applied WB+™**. DuPont Building Envelope Solutions Products are to be used as outlined in this installation guideline. **DuPont Self-Adhered Flashing** and **Tyvek® Fluid Applied Flashing and Joint Compound+** should only be used to seal penetrations and flash openings in buildings. **Tyvek® WRBs**, **Tyvek® Fluid Applied Products**, and **DuPont Self-Adhered Flashing Products** are not to be used in roofing applications. For superior protection against bulk water penetration, DuPont suggests a system combining a quality exterior facade, a good secondary air and water barrier and exterior sheathing, high quality windows and doors, and appropriate flashing materials paying attention to proper installation of each component.

In a system where no exterior sheathing is used and **Tyvek® WRBs** are installed directly over the wall studs, exterior facade materials should be selected to ensure maximum protection against water intrusion. Careful workmanship and proper installation of each component is very important.

Depending on job site conditions, it is possible that stains may appear, but will not alter performance of the **Tyvek® Fluid Applied Product**.

Safety and Handling Warning

Tyvek® WRBs are slippery and should not be used in any application where they will be walked on. In addition, because they are slippery, DuPont recommends using kickjacks, scaffolding, or lifts for exterior work above the first floor. If ladders must be used, extra caution must be taken to use them safely by following the requirements set forth in ANSI Standards 14.1, 14.2, and 14.5 for ladders made of wood, aluminum, and fiberglass, respectively. **DuPont™ Tyvek®** is combustible and should be protected from flames and other high heat sources. **DuPont™ Tyvek®** will melt at 275°F (135°C) and if the temperature of **DuPont™ Tyvek®** reaches 750°F (400°C), it will burn and the fire may spread and fall away from the point of ignition. For more information, call 1-833-338-7668.

DuPont Self-Adhered Flashing Products and their release paper are slippery and should not be walked on. Remove release paper from work area immediately. **DuPont Self-Adhered Flashing Products** will melt at temperatures greater than 250°F (121°C). **DuPont Self-Adhered**

Flashing Products are combustible and should be protected from flames and other high heat sources. **DuPont Self-Adhered Flashing Products** will not support combustion if the heat source is removed. However, if burning occurs, ignited droplets may fall away from the point of ignition. For more information, call 1-833-338-7668.

Tower® Residential Sealant (formerly DuPont™ Residential Sealant) is irritating to skin, eyes, and respiratory tract. For proper usage, follow directions stated on the product label. For health information, refer to the Safety Data Sheet (SDS) or call Chemtrec at 1-800-424-9300.

Tyvek® Fluid Applied Products may cause irritation. Repeated or prolonged skin contact may cause allergic reactions with susceptible persons. May cause irritation of respiratory tract. This product is a mixture. Health Hazard information is based on its components. Refer to the Safety Data Sheet (SDS) for further information.

KEEP OUT OF REACH OF CHILDREN.

Children can fall in to bucket and drown. Keep children away from bucket with even a small amount of liquid.

Use only as directed. Avoid inhalation of vapor aerosol.

Safety and Handling (continued)

Caution

Obtain special instructions for **Tyvek® Fluid Applied Products** before use. Do not handle until all safety precautions have been read and understood. Avoid breathing dust/fumes/gas/mist/vapors/spray. Vapor and aerosols are harmful if using spray application. Use in a well-ventilated area. Use NIOSH approved respirator. NIOSH-approved particulate filtering full-face respirator with a P95 particulate filter or half-mask respirator with a P95 particulate filter and splash impact goggles when spraying. NIOSH-approved N95 disposable safety mask with splash impact goggles for manual application such as troweling or rolling, and for clean-up. If vapors are inhaled, immediately move from exposure to fresh air and contact a physician. Contaminated work clothing should not be allowed out of the workplace. Wear protective gloves/protective clothing/eye protection/face protection. IF ON SKIN: Wash with plenty of soap and water. IF IN EYES: Rinse cautiously with water for several minutes. Remove contact lenses, if present and easy to do. Continue rinsing. IF exposed or concerned: Get medical advice/attention. Immediately call a POISON CENTER/doctor. If skin irritation or rash occurs: Get medical advice/attention. Wash contaminated clothing before reuse. Store locked up. Dispose of contents/container to an approved waste disposal

plant. Avoid contact with eyes and skin.

When cured, **Great Stuff Pro™ Window & Door Polyurethane Foam Sealant** is combustible and will burn if exposed to open flame or sparks from high-energy sources. Do not expose to temperatures above 240°F (116°C). For more information, consult the Safety Data Sheet (SDS), call DuPont at 1-866-583-2583. When air sealing buildings, ensure that combustion appliances, such as furnaces, water heaters, wood burning stoves, gas stoves and gas dryers are properly vented to the outside. See website: <https://www.nrel.gov/docs/fy14osti/61326.pdf>.

In Canada visit: <https://nrc-publications.canada.ca/eng/view/ft/?id=96acba7c-afd4-4ea1-94b0-1f8f3500c582>.

Great Stuff Pro™ polyurethane foam sealant and adhesive products contain isocyanate and a flammable blowing agent. Read all instructions and the Safety Data Sheet (SDS), carefully before use. Eliminate all sources of ignition before use. Cover all skin. Wear long sleeves, gloves, and safety glasses or goggles. Not for use in aviation, or food/beverage contact, or as structural support in marine applications. Provide adequate ventilation or wear proper respiratory protection. Contents under pressure. Not to be used for filling closed cavities or voids such as behind walls and under tub surrounds; this improper use of the product could

result in the accumulation of flammable vapors and/or uncured material. Failure to follow the warnings and instructions provided with the product, and/or all applicable rules and regulations, can result in injury or death.

Building and/or construction practices unrelated to building materials could greatly affect moisture and the potential for mold formation. No material supplied by DuPont can give assurance that mold will not develop in any specific system.

Read all instructions and the Safety Data Sheet (SDS) carefully before use.

For more information, visit greatstuffpro.com or building.dupont.com

Hazard Statement

Tyvek® Fluid Applied Products may cause an allergic skin reaction. May cause serious eye damage. May cause genetic defects. May damage fertility or the unborn child. As it relates to California

Prop 65, Tyvek® Fluid Applied Products can expose you to substances including Crystalline silica, which is /are known to the State of California to cause cancer. For more information, visit p65Warnings.ca.gov.

For More Information

Visit the *Quick Links* section of our website (<https://www.dupont.com/building/resources.html>) where you'll find links to essential documents and resources to help you get the job done right:

- Installation Guidelines
- Safety Data Sheets (SDS)
- CAD Drawings
- DuPont Performance Building Solutions Document Library

For complete warranty information please call 1-833-338-7668 or visit us at building.dupont.com.

NOTICE: No freedom from any patent owned by DuPont or others is to be inferred. Because use conditions and applicable laws may differ from one location to another and may change with time, Customer is responsible for determining whether products and the information in this document are appropriate for Customer's use and for ensuring that Customer's workplace and disposal practices are in compliance with applicable laws and other government enactments. The product shown in this literature may not be available for sale and/or available in all geographies where DuPont is represented. The claims made may not have been approved for use in all countries or regions. DuPont assumes no obligation or liability for the information in this document. References to "DuPont" or the "Company" mean the DuPont legal entity selling the products to Customer unless otherwise expressly noted. NO EXPRESS WARRANTIES ARE GIVEN EXCEPT FOR ANY APPLICABLE WRITTEN WARRANTIES SPECIFICALLY PROVIDED BY DUPONT. ALL IMPLIED WARRANTIES INCLUDING THOSE OF MERCHANTABILITY AND FITNESS FOR A PARTICULAR PURPOSE ARE EXPRESSLY EXCLUDED. The buyer assumes all risks as to the use of the material. Buyer's exclusive remedy or any claim (including without limitations, negligence, strict liability, or tort) shall be limited to the refund of the purchase price of the material. Failure to strictly adhere to any recommended procedures shall release DuPont de Nemours, Inc., and its affiliates, of all liability with respect to the materials or the use thereof. The information herein is not intended for use by non-professional designers, applicators or other persons who do not purchase or utilize this product in the normal course of their business.

© 2024 DuPont. DuPont™, the DuPont Oval Logo, and all trademarks and service marks denoted with ™, SM or ® are owned by affiliates of DuPont de Nemours, Inc. unless otherwise noted. Stinger® is a registered trademark of National Nail Corp. Grip-Deck®, Grip-Lok®, and Thermal-Grip FastCap™ are trademarks or registered trademarks of TRUFAST. Tower® is a registered trademark of Tower Sealants.

43-D101285-enNA-0124



For more information about
DuPont Performance Building Solutions,
please call 1-833-338-7668 or visit us at
building.dupont.com