



DuPont Performance Building Solutions

DuPont™ Tyvek® Fluid Applied WB+™ and DuPont Flashing Products Installation Guidelines



For Commercial and High-Performance
Buildings of Any Height

May 2025



Table of Contents

| | | | |
|---|-----------|--|-----------|
| Introduction..... | 3 | Cladding/Facade Fastener Considerations | 24 |
| Applicable Products | 3 | Joint Treatment Methods* | 25 |
| Required Materials Based on Project Requirements, Details, and Specifications ¹ | 3 | Repair | 26 |
| Coverage Rates | 3 | Equipment Recommendations..... | 26 |
| DuPont™ Tyvek® Fluid Applied Air Barrier System | 4 | Installation Methods for DuPont Flashing Products | 27 |
| DuPont Commercial Self-Adhered Flashing Products for use with DuPont™ Tyvek® Fluid Applied Products | 4 | Key Installation Requirements for Drainable Window / Door Installation | 27 |
| Safety, Handling, and Storage of DuPont™ Tyvek® Fluid Applied Products | 5 | Storefront Window..... | 28 |
| Warranty Information..... | 6 | Wood Bump-Out Frame with Non-Flanged Window..... | 44 |
| Applicable Structures and Performance Criteria..... | 6 | Wood Bump-Out Frame with Integral Flanged Window | 62 |
| Water-Resistive Barrier & Energy Conservation Codes and Standards | 8 | Steel Stud with Integral Flanged Window..... | 67 |
| Additional Codes and Standards Information for DuPont™ Tyvek® Commercial Air and Water Barrier Systems | 8 | Packaged Terminal Air Conditioner (PTAC) Unit | 89 |
| Flashing Products Code Requirements..... | 9 | Through Wall Flashing for Lintel Conditions..... | 102 |
| Special Considerations | 9 | Facade/Exterior Considerations | 104 |
| Application Over Sheathing | 11 | Product Composition and UV Stability..... | 105 |
| Drying/Curing..... | 11 | Design Considerations..... | 105 |
| DuPont™ Tyvek® Fluid Applied WB+™ Installation Instructions..... | 12 | Safety and Handling | 105 |
| Installation Method for New Construction..... | 12 | Hazard Statement..... | 106 |
| Continuity..... | 13 | For More Information..... | 106 |
| Top of Wall | 14 | | |
| Shelf Angle..... | 15 | | |
| Cantilevered Floor..... | 16 | | |
| Inside Corner | 17 | | |
| Outside Corner | 19 | | |
| Transitions | 20 | | |
| Hybrid Wall – Transition to DuPont™ Tyvek® WRBs* | 21 | | |
| Penetrations..... | 22 | | |

Introduction

This Installation Guideline outlines recommended installation techniques and details for **DuPont™ Tyvek® Fluid Applied Products** and, where applicable, **DuPont Self Adhered Flashing Products**. **DuPont™ Tyvek® Fluid Applied WB+™**, **DuPont™ Tyvek® CommercialWrap®** and **Tyvek® CommercialWrap® D** meet the requirements of a water-resistive barrier as defined in the 2024 International Building Code (IBC) and also functions as a high performance air barrier system. **Tyvek® Fluid Applied Products**, **Tyvek® CommercialWrap®**, and **Tyvek® CommercialWrap® D** installed with **DuPont Self-Adhered Flashing Products** function as high performance air barriers, pass ASTM E2357, and offer water infiltration resistance up to 15 psf when tested in accordance with ASTM E331.

Always check building.dupont.com for the latest versions of DuPont Installation Guidelines and other product literature.

Applicable Products

DuPont™ Tyvek® Fluid Applied Products

| Product | Quantity | Coverage |
|--|---------------|-----------------------------|
| DuPont™ Tyvek® Fluid Applied WB+™ | 5 gal, 50 gal | 50-65 ft ² /gal* |
| DuPont™ Tyvek® Fluid Applied Flashing and Joint Compound+ | 3.5 gal | 50-60 ft ² /gal* |
| Tyvek® Fluid Applied Flashing and Joint Compound+ (for sheathing seam treatment) | 28 oz | 1.8-2.3 LF/oz |

*Estimated surface coverage at 25 mils thick.

Mechanically-Fastened Water-Resistive and Air Barriers (Tyvek® WRBs)

| Product | Dimensions | Area |
|---|---------------------------------|--|
| DuPont™ Tyvek® CommercialWrap® | 5 ft x 200 ft 10 ft x 125 ft | 1,000 ft ² 1,250 ft ² |
| DuPont™ Tyvek® CommercialWrap® D | 5 ft x 200 ft 10 ft x 125 ft | 1,000 ft ² 1,250 ft ² |

DuPont Self-Adhered Flashing Products

| Product | Width |
|-------------------------------|--------------|
| DuPont™ FlexWrap™ | 6 in 9 in |
| DuPont™ FlexWrap™ EZ | 2.75 in |
| DuPont™ StraightFlash™ | 4 in 9 in |

Installation Accessories

| Product | Type | Quantity |
|---|---|----------|
| Great Stuff Pro™ Window & Door Polyurethane Foam Sealant | Can (reusable dispensing gun sold separately) | 20 oz |
| Great Stuff Pro™ Gaps & Cracks Polyurethane Foam Sealant | Can (reusable dispensing gun sold separately) | 20 oz |

Required Materials Based on Project Requirements, Details, and Specifications¹

- Backer Rod
- Sealant²
- Adhesive/Primer²
- Wet Mil Gauge
- Brushes for Surface Preparation
- J-Roller
- Trowels

¹Apply per manufacturers' guidelines. **For non DuPont products, DuPont assumes no liability in use of recommended products** — installers need to evaluate suitability of recommended products in their end-use applications.

²For information regarding chemically-compatible adhesive/primers, see technical bulletin [Chemical Compatibility of Representative Building Sealants and Adhesives/Primers](#).

Coverage Rates

Coverage rates may vary depending on application technique and substrate condition. **Tyvek® Fluid Applied WB+™** applied at a minimum thickness of 25 mils wet will offer a theoretical coverage (not including waste) as shown in the table below.

| Wall Substrate | Concrete Masonry Unit (CMU) | Exterior Gypsum Sheathing | Oriented Strand Board (OSB) | Plywood |
|----------------------------------|-----------------------------|---------------------------|-----------------------------|---------------------------|
| Theoretical Coverage Rate | ~ 50 ft ² /gal | ~ 65 ft ² /gal | ~ 60 ft ² /gal | ~ 60 ft ² /gal |

The installing professional should set a goal to ensure membrane is continuous (free of pinholes and voids) at an average thickness of 25 mils.

In general, the 3.5 gal bucket of **Tyvek® Fluid Applied Flashing and Joint Compound+** offers coverage of approximately 50-60 ft²/gal at 25 mils.

The 28 oz cartridge of **Tyvek® Fluid Applied Flashing and Joint Compound+** will treat approximately 1.8-2.3 LF/oz. for a 1/4" width x 1/4" depth bead (depending on substrate surface and joints). This is equivalent to approximately 11-13 ft²/gal per 28 oz cartridge @ 25 mils wet film thickness (depending on substrate surface). Rough surfaces can reduce coverage rates.



DuPont™ Tyvek® Fluid Applied Air Barrier System

DuPont™ Tyvek® Fluid Applied WB+™ is a silyl-terminated polyether (STPE) full-bodied (99% solids) single-component vapor permeable fluid applied that offers excellent elongation and recovery. **Tyvek® Fluid Applied WB+™** can be applied in single coat, has extremely low shrinkage during curing. **Tyvek® Fluid Applied WB+™** is non-water-soluble so it's not susceptible to freezing and/or wash off.

DuPont™ Tyvek® Fluid Applied Flashing and Joint Compound+ is a full-bodied vapor permeable silyl-terminated polyether (STPE) liquid flashing that is brush or trowel applied. **Tyvek® Fluid Applied Flashing and Joint Compound+** offers extremely low shrinkage and excellent air and water barrier performance. **Tyvek® Fluid Applied Flashing and Joint Compound+** can be used to protect rough openings for windows and doors, to fill seams, cracks and holes in the substrate, to seal around penetrations and to treat joints and transitions between building components.

DuPont Commercial Self-Adhered Flashing Products for use with DuPont™ Tyvek® Fluid Applied Products

DuPont™ StraightFlash™

StraightFlash™ is a premium self-adhered flashing protects the rough opening and/or window and door units. StraightFlash™ can be used to help address transitions and integration with other components of the wall assembly.

DuPont™ FlexWrap™

Premium extendable self-adhered flashing membrane specifically designed to provide seamless air and water barrier protection at window and door corners. **FlexWrap™** can be installed to sill and head of standard windows or round-top/ arched window as well as for wall penetrations.

DuPont™ FlexWrap™ EZ

FlexWrap™ EZ is a premium flexible flashing membrane configured to be easily installed around penetrations of all sizes.

StraightFlash™, FlexWrap™, and FlexWrap™ EZ combine a **DuPont™ Tyvek®** topsheet with a 100% butyl-based adhesive layer.

Safety, Handling, and Storage of DuPont™ Tyvek® Fluid Applied Products

WARNING: FOR PROFESSIONAL USE ONLY. Read and follow the entire *Safety, Handling, and Storage* section and the Safety Data Sheets (SDSs) carefully before use. The information below is designed to protect the user and allow for safe use and handling of **Tyvek® Fluid Applied Products**. Follow all applicable federal, state, local and employer regulations.

Precautionary Statements

Use only as directed. Avoid inhalation of vapor aerosol. Avoid breathing dust/fumes/gas/mist/vapors/spray. Contaminated work clothing should not be allowed out of the workplace. Wear protective gloves/protective clothing/eye protection/face protection. IF ON SKIN: Wash with plenty of soap and water. IF IN EYES: Rinse cautiously with water for several minutes. Remove contact lenses, if present and easy to do. Continue rinsing. IF EXPOSED OR CONCERNED: Get medical advice/attention. Immediately call a poison center/doctor. IF SKIN IRRITATION OR RASH OCCURS: Get medical advice/attention. Wash contaminated clothing before reuse. Store locked up. Dispose of contents/container to an approved waste disposal plant. Vapor and aerosols are harmful if using spray application. Use in a well-ventilated area. Use NIOSH approved respirator. If vapors are inhaled, immediately move from exposure to fresh air and contact a physician. Avoid contact with eyes and skin. See *Personal Protective Equipment* section below.

Hazard Statements

May cause an allergic skin reaction. May cause serious eye damage. May cause genetic defects. May cause cancer. May damage fertility or the unborn child. May cause irritation. Repeated or prolonged skin contact may cause allergic reactions with susceptible persons. May cause irritation of respiratory tract. **Tyvek® Fluid Applied Products** are mixtures and the hazard information is based on each product's components. **KEEP OUT OF REACH OF CHILDREN**, children can fall into bucket and drown.

Personal Protective Equipment (PPE)

Personal protective equipment (PPE) used during the handling of **Tyvek® Fluid Applied Products** must at a minimum include:

- Protective clothing or coveralls, including long sleeves and head cover (no skin should be exposed), for example, **DuPont™ Tyvek®** non-woven laminate paint protective coveralls with hood
- Chemical-resistant nitrile, butyl rubber, neoprene or PVC gloves
- Chemical splash impact safety goggles or equivalent, unless using a full-face respirator
- Protective work safety shoes
- Hearing protection such as ear plugs when spraying
- NIOSH-approved particulate filtering full-face respirator with a P95 particulate filter or half-mask respirator with a P95 particulate filter and splash impact goggles when spraying

- NIOSH-approved N95 disposable safety mask with splash impact goggles for manual application such as troweling or rolling, and for clean-up.

Clean Up and Purge

Use appropriate personal protective equipment during clean-up (see the *Personal Protective Equipment* section). Uncured **Tyvek® Fluid Applied Products** can be cleaned from hands, tools, and equipment by using a citrus based cleaner or mineral spirits. Cured **Tyvek® Fluid Applied Products** can be removed by soaking in citrus based cleaners or using a gel-based paint stripper.

Clean sprayer components and tools with 100% mineral spirits, naphtha, citrus-based cleaners, or gel-based paint stripper. Material should not be left in the pump, hose, gun, or roller. After applying, flush system with a citrus-based cleaner, or 100% mineral spirits until the system is clean. Avoid using water for cleanup. Low pressure portions of the system should be taken apart and cleaned by hand. Before the next usage, flush any remaining solvent out of the system before applying **DuPont™ Tyvek® Fluid Applied WB+™** to the wall substrate. Be sure that system is fully clean of any residual **Tyvek® Fluid Applied Product** before introducing a different product. If system is not fully clean, ingredients can react and cause products to cure in the system. Spray tips can be cleaned in 100% mineral spirits or naphtha using airbrush cleaning tools.

Shelf Life and Storage

The shelf life for **Tyvek® Fluid Applied Products** is 12 months for an unopened container from the date of manufacture. Reference the "Use By" date printed on the container. Store opened containers with a plastic protective liner to slow cure rate. Before reusing a previously opened container, first remove any cured material that may have formed (skinned over) at the top. **Expired material is deemed "not fit for use" and offers no warranty.**

Tyvek® Fluid Applied Products should be stored in a clean, dry environment, 50°- 80°F (10° - 27°C). If stored at temperatures below 65°F (18°C), the product must be warmed to a minimum of 65°F (18°C) prior to spraying using standard industry methods for proper atomization at the spray tip. Continuous storage at high temperatures will reduce the shelf life of **Tyvek® Fluid Applied Products**. **Tyvek® Fluid Applied Products** should be placed under a cover when they are temporarily stored outside.

Disposal

Dispose of any residual **Tyvek® Fluid Applied Product**, coated debris, or solvent in accordance with applicable federal, state, and local government regulations.

Supplemental Information

Avoid spraying **Tyvek® Fluid Applied WB+™** in very windy conditions. Installing professional should consider if structure should be tented to protect the surrounding area from overspray. Avoid spraying in very dusty conditions.

Warranty Information

Please refer to [DuPont™ Tyvek® Fluid Applied Products Limited Warranty](#) for information relative to this guide. For commercial buildings with hybrid conditions and/or using **DuPont™ Tyvek® CommercialWrap®** or **Tyvek® CommercialWrap® D** as the water and air barrier, please refer to [DuPont Building Envelope Solutions Products 10-Year Limited Warranty for Commercial and High Performance Buildings or Any Height](#). For wood framed multi-family and light commercial buildings, please refer to the [DuPont Building Envelope Solutions Products 10-Year Limited Warranty for Wood-Framed Multi-Family and Light Commercial Buildings](#). For single-family buildings, please refer to the [DuPont Building Envelope Solutions Products 10-Year Limited Warranties for Single-Family Residential Buildings](#).

NOTE: In order to make a claim under the DuPont 10-Year Limited Product and Labor Warranty on DuPont Building Envelope Solutions Products, all terms and conditions of the warranty must be met, including use of the applicable DuPont Installation Guidelines available at the date of original installation. Please contact DuPont or a DuPont Sales Representative responsible for **DuPont™ Tyvek® Fluid Applied Products** in the project area if you have any questions in connection with any DuPont Installation Guideline.

Applicable Structures and Performance Criteria

Applicable Structures

These Installation Guidelines are for Commercial and High-Performance Buildings of Any Height as defined below.

NOTE: The details captured within this guide can also be used for other construction types (e.g., residential single family, wood-framed multi-family, and light commercial).

DuPont categorizes structures into three primary groups:

- i.) **“Single-Family Residential Buildings”** are defined as fully-detached one or two family structures, as well as townhouse structures not more than three stories above grade plane as defined in the 2024 International Residential Code (IRC) Section R101.2, both to the extent they are exclusively Residential Use building structures.
- ii.) **“Wood-Framed Multi-Family and Light Commercial Buildings”** are defined as the following (must meet **ALL** criteria):
 - a. Constructed of wood-based structural exterior framing of Type III or Type V Construction* (IBC Chapter 6); and
 - b. Does not exceed 2024 IBC max height (Table 504.3) for Type V construction (70 ft) or Type III construction (85 ft), including allowances for Automatic Sprinkler height increase (IBC 504.1 and Table 504.4) and ‘podium’ structures outlined in the Special Provisions* (IBC Section 510); and
 - c. Design requirements for the building envelope do not exceed air barrier performance of ASTM E1677 (10.8 psf structural load, 65 mph equivalent wind load), and water infiltration resistance criteria of 6.24 psf (50 mph equivalent wind-driven rain) when tested in accordance with ASTM E331, ASTM E1105, or equivalent.

*Special Provisions (IBC Section 510) allows for a “horizontal building separation”, or ‘podium’, to be built under the wood-framed Type III or Type V building. The podium is typically constructed of steel framing or concrete. Podium-style buildings are included under “Wood-Framed Multi-Family and Light Commercial Buildings”, as long as all other definition criteria (a. through c. above) are met.
- iii.) **“Commercial and High-Performance Buildings of Any Height”** can be defined as any of the following:
 - a. Structures constructed of steel-based structural exterior framing and any exterior sheathing, or
 - b. Structures with exterior above grade walls constructed of concrete or concrete masonry units (CMU), or
 - c. Structures of any height and construction type (including any framing type) that are designated as high-performance. “High-performance” is defined as air barrier performance exceeding ASTM E1677 and/or water infiltration resistance criteria exceeding 6.24 psf when tested in accordance with ASTM E331, ASTM E1105, or equivalent.

NOTE: “Podium” style structures with wood-framed floors built above steel-framed or concrete/CMU floors are covered under “Wood-Framed Multi-Family and Light Commercial Buildings” unless they are “high-performance”.

Applicable Structures and Performance Criteria

Water-Resistive Barrier Performance Requirements

Buildings with high-performance air barrier designs are defined by DuPont as those with air barrier performance equivalent to ASTM E2357 (or other exceeding ASTM E1677), and/or water infiltration resistance criteria greater than 6.24 psf when tested in accordance with ASTM E331, ASTM E1105, or equivalent. Installation of DuPont Building

Envelope Solutions Products on high-performance buildings requires the use of the [DuPont™ Tyvek® Mechanically-Fastened Water-Resistive and Air Barrier \(WRB\) and DuPont Self-Adhered Flashing Products Installation Guidelines For Commercial and High-Performance Buildings of Any Height](#).

These Installation Guidelines should be used for buildings which meet the applicable structures definitions and performance criteria on the previous page. The following table provides a summary of typical installation information.

DuPont™ Tyvek® Fluid Applied Products Installation Considerations for Commercial and High-Performance Buildings of Any Height

| | |
|------------------------------------|--|
| Performance Criteria | Buildings with high-performance air barrier designs are defined by DuPont as those with air barrier performance equivalent to ASTM E2357 (or other exceeding ASTM E1677), and/or water infiltration resistance criteria greater than 6.24 psf when tested in accordance with ASTM E331, ASTM E1105, or equivalent. |
| Air and Water Barrier | DuPont™ Tyvek® Fluid Applied WB+™ |
| Intended Application Area | DuPont™ Tyvek® Fluid Applied Products are intended for above grade exterior wall substrates as outlined in the Special Considerations section. Tyvek® Fluid Applied Products can be used with DuPont™ Tyvek® WRBs and DuPont Self-Adhered Flashing Products as captured in the Hybrid Wall detail in this guide and from the Hybrid Condition section in the applicable DuPont Installation Guideline. |
| Air Barrier Details | Required when the designated building envelope performance requirements are equivalent to and/or exceed ASTM E1677 (65 mph equivalent structural load and 15 mph equivalent wind-driven rain water infiltration resistance). |
| Sheathing Seam Treatment | Where applicable, the sheathing seams should be pretreated with DuPont™ Tyvek® Fluid Applied Flashing and Joint Compound+ as outlined in the Joint Treatment Methods section in this guide. |
| Cladding Fastener Treatment | Required when water infiltration resistance criteria of the building envelope design requirements specifies ASTM E2357 and/or water infiltration resistance > 3.14 psf (35 mph). Refer to the Cladding/Facade Fastener Considerations section of this guide for more information. |

Water-Resistive Barrier & Energy Conservation Codes and Standards

The 2024 International Building Code (Section 1402.2 Weather Protection) requires that “building shall be provided with a weather-resistant exterior wall assembly. The exterior wall assembly shall include flashing, as described in Section 1404.2. The exterior wall assembly shall be designed and constructed in such a manner as to prevent the accumulation of water within the exterior wall assembly by providing a water-resistive barrier behind the exterior veneer, as described in Section 1403.2, and a means for draining water that enters the assembly to the exterior. Protection against condensation in the exterior wall assembly shall be provided in accordance with Section 1404.3.

DuPont™ Tyvek® Fluid Applied WB+™ meets ICC-ES AC212, *Acceptance Criteria for Water-Resistive Coatings Used as Water-Resistive Barriers Over Exterior Sheathing*, per the following:

Intertek Code Report: CCR-0307 for **Tyvek® Fluid Applied WB+™**

The DuPont™ Tyvek® Commercial Building Wraps listed below qualify as approved water-resistive barriers based on ICC-ES AC38 *Acceptance Criteria for Water Resistive Barriers* according to the associated Evaluation Report:

- ICC-ES Evaluation Report ESR 2375
 - **DuPont™ Tyvek® CommercialWrap®**
 - **DuPont™ Tyvek® CommercialWrap® D**

Air leakage control and air barriers are required in the IECC-2018 Sections R402.4 and C402.5. Specifically, Section C402.5 identifies three compliance options for air barriers. **Tyvek® WRBs** comply with the option detailed in Section C402.5.1.2.1 Materials: “Materials with an air permeability no greater than 0.004 cfm/ft² (0.02 L/s x m²) under a pressure differential of 0.3 inches water gauge (75 Pa) when tested in accordance with ASTM E2178 shall comply with this section.” **Tyvek® WRBs** have been tested in accordance with ASTM E2178 and have air permeability less than 0.004 cfm/ft² (0.02 L/s x m²).

Additional Codes and Standards Information for DuPont™ Tyvek® Commercial Air and Water Barrier Systems

DuPont™ Tyvek® Fluid Applied Products, Tyvek® CommercialWrap®, Tyvek® CommercialWrap® D, DuPont™ FlexWrap™, and **DuPont™ StraightFlash™** were designed for the rigors of heavy commercial construction. These commercial products have been tested to the following standards:

- ABAA Evaluated
- ASTM E2357, *Standard Test Method for Determining Air Leakage of Air Barrier Assemblies*
- ASTM E283, *Standard Test Method for Determining Rate of Air Leakage Through Exterior Windows, Curtain Walls and Doors Under Specified Pressure Differences Across the Specimen*
- ASTM E331, *Standard Test Method for Water Penetration of Exterior Windows, Skylights, Doors, and Curtain Walls by Uniform Static Pressure*
- ASTM E1677, *Standard Specification for Air Barrier (AB) Material or System for Low-Rise Framed Building Walls*
- ASTM E2178, *Standard Test Method for Air Permeance of Building Materials*
- ASTM E96, *Standard Test Methods for Water Vapor Transmission of Materials*
- ASTM E84, *Standard Test Method for Surface Burning Characteristics of Building Materials*
- AATCC 127, *Hydrostatic Head Test for WRB Materials, measuring pressure to failure or time of failure at a given pressure*
- AAMA 711, *Specification for Self Adhering Flashing Used for Installation of Exterior Wall Fenestration Products*
- AAMA 714, *Voluntary Specification for Liquid Applied Flashing Used to Create a Water-Resistive Seal Around Exterior Wall Openings in Buildings¹*
- ASTM C1305, *Standard Test Method for Crack Bridging Ability of Liquid-Applied Waterproofing Membrane*
- ASTM D412, *Standard Test Methods for Vulcanized Rubber and Thermoplastic Elastomeric – Tension*
- NFPA 285, *Standard Fire Test Method for Evaluation of Fire Propagation – Characteristics of Exterior Non-Load Bearing Wall Assemblies Containing Combustible Components*

Energy Conservation Codes for commercial buildings are being adopted in many regions across the U.S. When properly installed, **Tyvek® Fluid Applied Products** meet the following codes and guidelines.

- ASHRAE 90.1 Model Energy Code air barrier requirements
- 2024 International Energy Conservation Code® (IECC)
- 2024 International Green Construction Code™ (IgCC)

¹ This reference only applies to **Tyvek® Fluid Applied Flashing and Joint Compound+**

Flashing Products Code Requirements

The 2024 International Building Code (Section 1404.4 Flashing) requires that “flashing shall be installed in such a manner so as to prevent moisture from entering the wall or to redirect that moisture to the exterior. Flashing shall be installed at the perimeters of exterior door and window assemblies, penetrations and terminations of exterior wall assemblies, exterior wall intersections with roofs, chimneys, porches, decks, balconies and similar projections and at built-in gutters and similar locations where moisture could enter the wall. Flashing with projecting flanges shall be installed on both sides and the ends of copings, under sills and continuously above projecting trim. Where self-adhered membranes are used as flashings of fenestration in wall assemblies, those self-adhered flashings shall comply with **AAMA 711**. Where fluid applied membranes are used as flashing for exterior wall openings, those fluid applied membrane flashings shall comply with **AAMA 714**.”

- **DuPont Self-Adhered Flashing Products** comply with AAMA 711 (an FGIA Specification) *Specification for Self Adhering Flashing Used for Installation of Exterior Wall Fenestration Products*.
- **DuPont™ Tyvek® Fluid Applied Flashing and Joint Compound+** complies with AAMA 714, *Voluntary Specification for Liquid Applied Flashing Used to Create a Water-Resistive Seal around Exterior Wall*.

Special Considerations

NOTE: DuPont™ Tyvek® Fluid Applied Products should only be used for wall systems that include a continuous path for drainage allowing moisture that penetrates the facade to exit to the exterior. The drainage path should be continuous throughout the wall assembly, including but not limited to areas such as eyebrows, band boards, penetrations, or other locations where transitions and changes of plane occur.

For membrane drainage wall systems, ensure that the drainage path is not blocked or disrupted to prevent excess moisture buildup in the wall cavity. Proper shingling, sealing, and integration of the **Tyvek® Fluid Applied Products** with kick-out flashings, through wall membranes, window and door flashing, and other wall transitions is essential for moisture drainage to the exterior.

NOTE: As soon as practically possible, cap the top of the wall system to reduce the likelihood of water getting behind the facade and/or wall substrate and into the wall cavity.

1. Suitable substrates include concrete masonry unit (CMU), concrete (>48 hours for green concrete), exterior gypsum, OSB, plywood, wood, wood-based FRT¹, and metal.
2. **Tyvek® Fluid Applied Products** should be installed on clean surface that is free of dirt, grease and other debris that could interfere with adhesion.
3. **Tyvek® Fluid Applied Products** are designed for above grade application and should not be installed below grade.

4. When **DuPont™ Tyvek® Fluid Applied WB+™** is applied with a sprayer, the outer edges of all interfaces with **DuPont Self-Adhered Flashing Products** should be pretreated with **DuPont™ Tyvek® Fluid Applied Flashing and Joint Compound+** and tapered to the wall substrate to ensure smooth transitions free of pinholes and voids.
5. **Tyvek® Fluid Applied Products** can be applied to damp surfaces. A surface is considered damp if there is no visible water on the surface and no transfer of water to the skin when touched.
6. When applying **Tyvek® Fluid Applied Products** over wood-based substrates such as OSB, plywood, lumber, treated lumber, and fire-retardant treated (FRT) wood, the installing professional should ensure the moisture content, measured with a wood moisture meter in the core of the substrate, shall be below 20%. **Do not cover wood-based substrates with Tyvek® Fluid Applied Products if moisture content is 20% or above.**
7. **Tyvek® Fluid Applied Flashing and Joint Compound+** can be troweled or brushed to the required thickness in any application outlined in the guide.
8. **Tyvek® Fluid Applied Products** should be applied when air and surface temperatures are above 25°F. Do not install once the ambient temperature exceeds 95°F (35°C), unless the application surface is shaded. The maximum surface temperature for application is 140°F (60°C).
9. For best results, the temperature of the **Tyvek® Fluid Applied Products** at the spray tip of standard spray equipment should be 65°F (18°C) or higher. This may require employing measures to keep the pump and spray equipment at temperatures above 65°F (18°C) and/or using an insulated hose.
10. The maximum in-service temperature of the final cured **Tyvek® Fluid Applied Products** and **DuPont Self-Adhered Flashing Products** is 180°F (82°C).
11. **Tyvek® Fluid Applied Products** may be overcoated once a tack-free skin has formed. Exterior insulation and/or exterior facade may be installed after **Tyvek® Fluid Applied Products** have cured for 48 hours. For more information, see the [Drying/Curing](#) section of this guide.
12. **Tyvek® Fluid Applied WB+™** may be applied over and integrated with **Tyvek® Fluid Applied Flashing and Joint Compound+** once a tack-free skin has formed. Skin over time is ~1 – 2 hours at 70°F (20°C) 50% RH. Refer to table in the [Drying/Curing](#) section of this guide for more information.
13. Performance testing, included but not limited to peel adhesion, pull strength analysis, field or third party testing of air and/or water barrier properties, should be conducted after **Tyvek® Fluid Applied Products** are fully cured (~14 days).
14. DuPont requires that **Tyvek® Fluid Applied Products** be covered within nine months (270 days) of installation.

¹Please contact DuPont to determine if proposed wood-based FRT product is suitable for use with **DuPont™ Tyvek® Fluid Applied Products**.

Special Considerations

15. **DuPont Self-Adhered Flashing Products** should be applied to clean, dry surfaces that are free of frost. Wipe surfaces to remove dirt, grease and other debris that could interfere with adhesion.
16. DuPont requires that **DuPont™ FlexWrap™**, **DuPont™ FlexWrap™ EZ**, and **DuPont™ StraightFlash™** be covered within nine months (270 days) of installation.
17. **DuPont Self-Adhered Flashing Products** and **DuPont™ Tyvek® Fluid Applied Products** should **not** be used in applications where through wall flashing membranes are intended.
18. **StraightFlash™** can be used to bridge non-moving gaps up to 1". Flashing must maintain a 2" adhesive lap on both wall substrates.
19. **DuPont Self-Adhered Flashing Products** perform best when air and surface temperatures are above 25°F (-4°C).
20. For **DuPont Self-Adhered Flashing Products**, remove all wrinkles and bubbles that may allow for water intrusion by smoothing surface and repositioning as necessary during installation.
21. If **DuPont Self-Adhered Flashing Products** are used for window, doors and/or pipe penetrations, in conjunction with **Tyvek® Fluid Applied Products**, the **DuPont Self-Adhered Flashing Products** should be installed to a primed wall surface before **Tyvek® Fluid Applied Products** are applied.
22. For window or door openings greater than 6 feet wide, **StraightFlash™** can be used with **FlexWrap™** in 3-piece sill/head applications. **StraightFlash™** should be applied the length of the sill prior to placing the **FlexWrap™** corners. The **FlexWrap™** corners should be at least 12" long allowing for 6" up the jamb and 6" of overlap on the **FlexWrap™** sill flashing. When applying the 3-piece flashing detail to the head of the opening, the **StraightFlash™** head piece should be applied prior to installing the **FlexWrap™** corner flashing. The **FlexWrap™** head flashing should overlap the jamb flashing by a minimum of 6". **Registered DuPont Commercial Certified Installers may use the 3-piece sill/head flashing method on window and door openings of any size.**
23. Before applying **DuPont Self-Adhered Flashing Products** to cured **Tyvek® Fluid Applied Products**, a wet bed of **Tyvek® Fluid Applied Product** must be installed. This sequence is required to ensure a robust integration between the self-adhered and fluid applied products.
24. **A chemically-compatible adhesive/primer is required when applying DuPont Self-Adhered Flashing Products on concrete, masonry, and fiber faced exterior gypsum board substrates.** Priming is generally not required for adhering **DuPont Self-Adhered Flashing Products** to wood. Please refer to the technical bulletin [Chemical Compatibility of Representative Building Sealants and Adhesives/Primers](#) for additional information on chemically-compatible adhesives/primers.
25. Priming is only required for **Tyvek® Fluid Applied Products** when applied to cut edges of exterior gypsum sheathing.
26. Uncured **Tyvek® Fluid Applied Products** and/or competitive fluid applied/waterproofing products **must not** come in contact with **DuPont™ Tyvek® Mechanically-Fastened WRBs** due to potential impact on performance properties.
27. **Tyvek® Fluid Applied Products** should not be placed in direct contact with competitive fluid applied products. **StraightFlash™** can be used as a transitional membrane.
28. Stirring is not necessary. If separation occurs, gently fold material until mixture is uniform. Avoid any type of mixing that will introduce air into the product.
29. Asphalt based adhesives are **not recommended** for use with **Tyvek® Fluid Applied Products**.
30. Minor discoloration of the membrane at wood knots, sap, or sheathing inks may occur after curing.
31. When **Tyvek® Fluid Applied Products** are used as the primary air and water barrier, **Tyvek®** mechanically-fastened air and water barrier products may be installed as an "intervening layer" over **Tyvek® Fluid Applied Products** after 24 hours of curing at 70°F (20°C) and 50% RH. For additional information about the use of "intervening layers", see "Stucco" in the [Facade/Exterior Considerations](#) section of this guide.
32. DuPont recommends **Tyvek® Fluid Applied Products** for CMU walls with embedded brick ties.
33. **Tyvek® Mechanically-Fastened WRBs should NOT be used on CMU walls with embedded brick ties.**
34. When **DuPont™ Tyvek® CommercialWrap®** or **Tyvek® CommercialWrap® D** is installed as part of a hybrid wall condition, the **DuPont™ Tyvek® WRB** must be installed in accordance with the [DuPont™ Tyvek® Mechanically-Fastened Water-Resistive and Air Barrier \(WRB\) and DuPont Self-Adhered Flashing Products Installation Guidelines](#).
35. For guidance on the use of **Tyvek® Fluid Applied Products** with **DuPont Exterior Continuous Installation**, refer to the applicable Commercial Wall² installation bulletin, [DuPont™ Tyvek® Fluid Applied WB+™ UNDER DuPont Exterior Continuous Insulation](#) or [DuPont™ Tyvek® Fluid Applied WB+™ OVER CMU with Embedded Brick Ties and UNDER DuPont™ Styrofoam™ Brand XPS Insulation Products](#).
36. For commercial bump-out window conditions refer to [DuPont Commercial Flashing Products Installation Guidelines Bump-Out Frame Conditions](#). The hybrid details offer greater flexibility to address more complex bump-out conditions.
37. Buildings requiring NFPA 285 compliance must use **Tyvek® Fluid Applied Products**, **Tyvek® CommercialWrap®**, or **Tyvek® CommercialWrap® D** in accordance with [DuPont NFPA 285 documentation](#).
38. Please refer to the installation bulletin [Additional Considerations When Spraying DuPont™ Tyvek® Fluid Applied WB+™](#) for additional guidance when applying the product with an airless sprayer.

For additional guidance, please call 1-833-338-7668, visit our website at www.fluidapplied.tyvek.com.

Application Over Sheathing

DuPont™ Tyvek® Fluid Applied WB+™ may be installed over exterior gypsum, OSB, and plywood sheathing. Sheathing should be clean and free from any materials that could negatively affect adhesion. When installing over sheathing, it is important that all sheathing seams be pretreated using the appropriate [Joint Treatment Methods](#) in this guide. All flashing and detailing should be completed before installation of **Tyvek® Fluid Applied WB+™**. When applying over exterior gypsum, all cut edges along outside corners and rough openings should first be primed with a [chemically-compatible adhesive/primer](#).

When spraying **Tyvek® Fluid Applied WB+™**, pretreat all overdriven sheathing fasteners with **DuPont™ Tyvek® Fluid Applied Flashing and Joint Compound+**. Application to sheathing substrate and sheathing fasteners should be free of pinholes and voids. Installer should treat any pinholes and voids using **DuPont™ Tyvek® Fluid Applied Products**. Please refer to the bulletin [Additional Considerations When Spraying DuPont™ Tyvek® Fluid Applied WB+™](#) for more information relative to spraying.

Tyvek® Fluid Applied WB+™ can be sprayed or rolled on nonporous substrates, such as gypsum sheathings, in a 25-mil (0.635 mm) wet coat. **Tyvek® Fluid Applied WB+™** can be rolled or sprayed on porous substrates such as CMU and non-uniform substrates such as wood sheathing and OSB. When sprayed on porous and/or non-uniform substrates back rolling may be required. When back rolling, use a roller cover with a 1/2" to 3/4" nap. **Tyvek® Fluid Applied WB+™** needs only to be applied in a single coat at 25 mils thick. Refer to table in the *Drying/Curing* section, at right, for skin and working times. The thickness should be controlled by applying the appropriate volume over a marked area and by spot checking with a wet mil gauge. Upon completion, inspect the membrane to ensure that it is continuous and free of any voids or pinholes.

Tyvek® Fluid Applied Products may be overcoated once a tack-free skin has formed. Refer to table in the *Drying/Curing* section for skin and working times.

Drying/Curing

The **Tyvek® Fluid Applied Products** skin over and are dry to touch within 1 – 2 hours under normal conditions (70°F (20°C), and 50% RH). Cure time may be slower with lower ambient temperatures and/or RH.

NOTE: Tyvek® Fluid Applied Products installed on manufactured wall panels may require site-specific drying/curing considerations.

Uncured **Tyvek® Fluid Applied Products** should not come in contact with **DuPont™ Tyvek® WRBs**. Performance testing can commence after membrane is fully cured, approximately 14 days. See table below for additional details.

| Use Recommendations | Application | Time |
|--|---|-----------|
| Skin Over ¹ | Minor touchups | 1-2 Hours |
| Workable ² | Cladding/Façade Fasteners | 24 Hours |
| Exterior Façade / Exterior Insulation | | 48 Hours |
| DuPont™ Tyvek® CommercialWrap® / Tyvek® CommercialWrap® D | When DuPont™ Tyvek® Fluid Applied Flashing and Joint Compound+ is used as Sheathing Seam Treatment | 48 Hours |
| | Intervening Layer | 24 Hours |
| Complete Cure | End-Use Testing ³ | 14 Days |

¹ Time required for **Tyvek® Fluid Applied Products** to form a surface that is non-transferable to the touch.

² Time required for surface of **Tyvek® Fluid Applied Products** to be more resistant to minor abrasion.

³ End-Use Testing include water infiltration field testing, 3rd Party assembly testing, peel adhesion and/or pull testing.

DuPont™ Tyvek® Fluid Applied WB+™ Installation Instructions

Installation Method for New Construction

STEP 1: PREPARATION

Clean substrate by removing any substance that may affect the adhesion of **DuPont™ Tyvek® Fluid Applied Products**, such as frost, oil, grease, mold and efflorescence. Remove all dust, dirt and loose mortar from the substrate using a trowel or brush. CMU substrates should be free of holes and excess mortar. Fill all head and bed joints with mortar. Mortar joints should be struck flush to help limit pretreatment or post treatment of joints.

STEP 2: FLASHING

- Install a through wall flashing at all necessary locations (e.g. base of the wall, shelf angles, heads of windows, etc.), see [Continuity](#) section for additional information.
- Install **DuPont™ Tyvek® Fluid Applied Flashing and Joint Compound+** or **DuPont Self-Adhered Flashing Products** around windows and doors in accordance with the [Installation Methods for DuPont Flashing Products](#) section of this guide.

NOTE: For spray applications of **DuPont™ Tyvek® Fluid Applied WB+™**, the outer edge of **DuPont Self-Adhered Flashing Products** should be pretreated with **Tyvek® Fluid Applied Flashing and Joint Compound+** tapered to the wall substrate to help ensure installation is free of pinholes and voids.

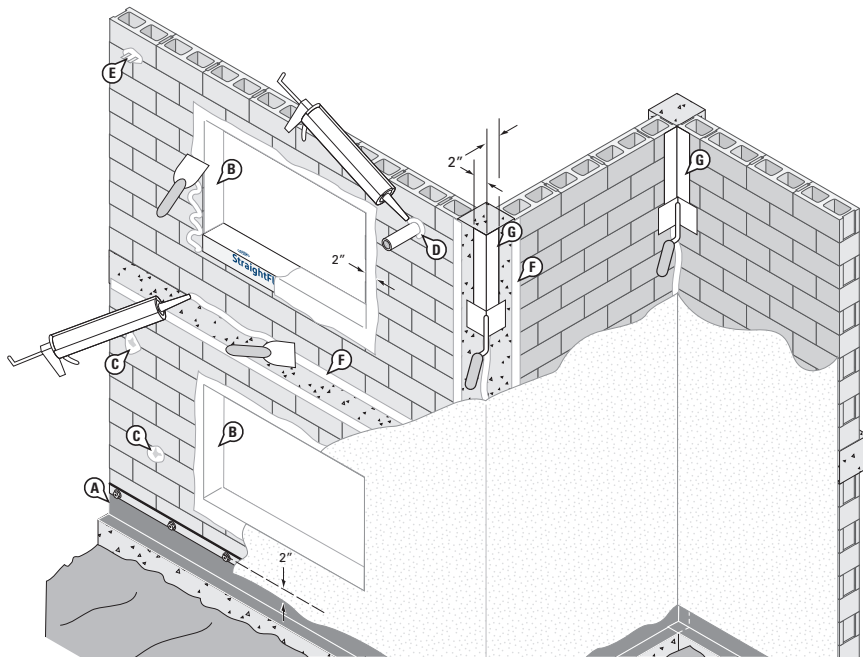

STEP 3: WALL/SUBSTRATE PREPARATION

- Fill small cracks and voids in masonry with **Tyvek® Fluid Applied Flashing and Joint Compound+**. Large voids should be filled flush with mortar and allowed to cure.
- Seal around all penetrations using **Tyvek® Fluid Applied Flashing and Joint Compound+**. The fillet bead should extend 1/2" onto both surfaces (see the [Penetrations](#) section for detail).
- As a best practice, DuPont recommends that all embedded masonry anchors be treated by troweling or brushing a coat of **Tyvek® Fluid Applied WB+™** or **Tyvek® Fluid Applied Flashing and Joint Compound+** around the base of the anchor. See the [Brick Ties, Cladding Supports, and Furring Strips](#) section of this guide for additional fastener sealing recommendations.
- Treat all non-moving transition joints to beams, columns, and dissimilar materials (up to 1/4") by applying a 2" wide, 60 mil thick coat of **Tyvek® Fluid Applied Flashing and Joint Compound+** across the joint. Grouted joints between similar materials do not need to be treated. Transition joints up to 1/2" should be reinforced with fiberglass mesh tape. **DuPont™ StraightFlash™** should be used for transition joints up to 1" following the primer requirements included in the [Special Considerations](#) section of this guide. The **StraightFlash™** should extend a minimum of 2" onto each surface. Refer to the [Joint Treatment Methods](#) section of this guide for additional information about transition joints.
- Treat all inside and outside corners by applying a 25 mil thick coat of **Tyvek® Fluid Applied Flashing and Joint Compound+**, 2" onto each adjoining surface. It is recommended that a fillet bead of **Tyvek® Fluid Applied Flashing and Joint Compound+** be applied to corners to help ensure continuity. Alternately, corners may be treated using **StraightFlash™**. Be sure that **StraightFlash™** is pressed tightly into the inside corners and is fully adhered to substrate. See the [Special Considerations](#) section of this guide for priming requirements.

STEP 4: AIR AND WATER-RESISTIVE BARRIER

Tyvek® Fluid Applied WB+™ can be sprayed or rolled on nonporous substrates such as gypsum sheathings, in one 25-mil (0.635 mm) wet coat, but may require back rolling. Porous substrates such as CMU and non-uniform substrates such as wood sheathing and OSB can be sprayed but may require back rolling. When back rolling, use a roller cover with a 1/2" to 3/4" nap. **Tyvek® Fluid Applied WB+™** needs only to be applied in a single coat at 25 mils thick. See table in the [Coverage Rates](#) section of this guide for substrate specific information. Thickness should be controlled by applying the appropriate volume over a marked area and by spot checking with a wet mil gauge. Integrate **Tyvek® Fluid Applied WB+™** with through wall flashing and window/door flashing by overlapping the flashing with **Tyvek® Fluid Applied WB+™** by a minimum of 2". Upon completion, inspect the membrane to ensure that it is continuous and free of any voids or pinholes.

DuPont™ Tyvek® Fluid Applied WB+™ Installation Instructions

Continuity

It is important to maintain the continuity of the water-resistive barrier from top to bottom. The entire wall surface shall be covered, including unconditioned spaces. Special attention should be given to all terminations, transitions, projections, and penetrations to ensure a proper drainage plane and continuous water-resistive barrier.

Foundation

These installation methods and considerations apply to foundation and individual floor line conditions where applicable per architectural construction details.

Method 1: Using DuPont™ Tyvek® Fluid Applied Products

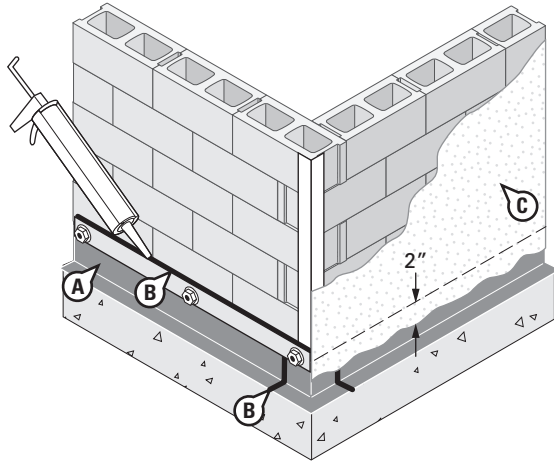

- Install through wall flashing in accordance with the through wall flashing manufacturer's installation guidelines.
- Apply **DuPont™ Tyvek® Fluid Applied Flashing and Joint Compound+** or a [chemically-compatible sealant](#) along the top edge of the through wall flashing and/or termination bar and to all seams. Allow the **Tyvek® Fluid Applied Product** to form a tack-free skin before applying **Tyvek® Fluid Applied WB+™** (refer to the [Drying/Curing](#) table for skin and working times).
- Apply **Tyvek® Fluid Applied WB+™** onto wall surface at 25 mils thick. Overlap through wall flashing by a minimum of 2".

Method 2: Using DuPont™ StraightFlash™

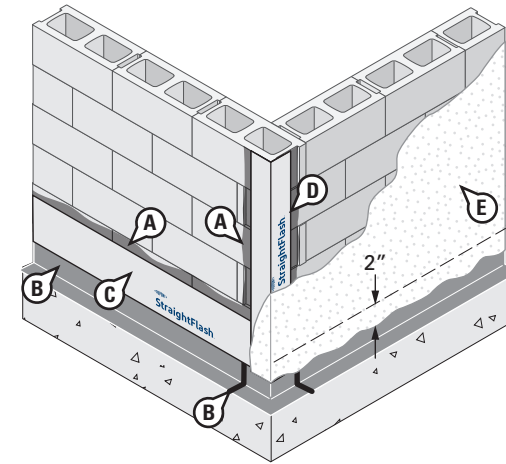

- Apply a [chemically-compatible adhesive/primer](#) to wall substrate where self-adhered flashing will be installed.
- Install through wall flashing in accordance with the through wall flashing manufacturer's installation guidelines. If through wall flashing installation guidelines require a sealant along the exposed seam and/or perimeter edges, please refer to the technical bulletin [Chemical Compatibility of Representative Building Sealants and Adhesives/Primers](#) for additional information on chemically-compatible adhesives/primers.
- Install **StraightFlash™** along the top edge of the through wall flashing. Use of **StraightFlash™** can help address chemical compatibility concerns with asphaltic adhesives, sealant, and/or mastics.
- Apply **StraightFlash™** along outside corner.
- Apply **Tyvek® Fluid Applied WB+™** onto wall surface at 25 mils thick. Overlap **StraightFlash™** by a minimum of 2". Ensure application is continuous, free of pinholes and/or voids.

NOTE: When spraying, the outer edge of **DuPont Self-Adhered Flashing Products** should be treated with **Tyvek® Fluid Applied Flashing and Joint Compound+** tapered to the wall substrate to help ensure installation is free of pinholes and voids.

DuPont™ Tyvek® Fluid Applied WB+™ Installation Instructions

Continuity

Top of Wall

Method 1: Using DuPont™ Tyvek® Fluid Applied Products

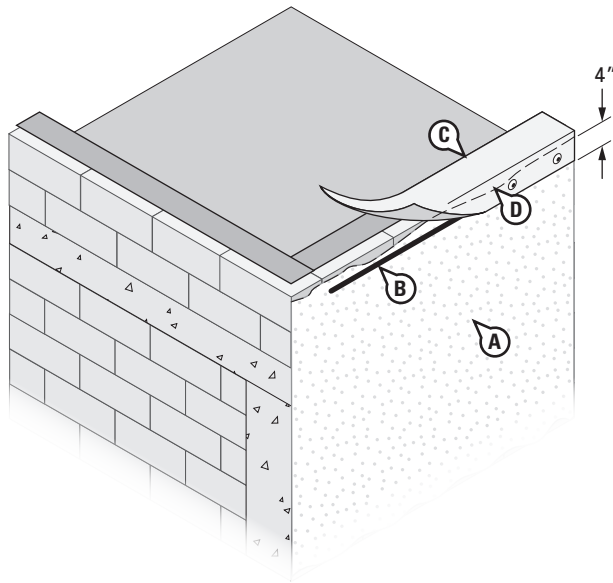

- A. **Tyvek® Fluid Applied WB+™** should be installed prior to the installation of the parapet flashing membrane.
- B. Apply a liberal bead of **DuPont™ Tyvek® Fluid Applied Flashing and Joint Compound+** or a *chemically-compatible sealant* onto the **Tyvek® Fluid Applied WB+™** at a location that will be approximately 2" up from the bottom edge of the parapet flashing membrane.
- C. While the sealant bead is still wet, install the parapet/roofing flashing membrane over the top of the parapet, extending a minimum of 4" onto the **Tyvek® Fluid Applied WB+™**.
- D. Press roofing membrane into sealant and secure using mechanical fasteners installed through the membrane and sealant bead.

Method 2: Using DuPont™ StraightFlash™

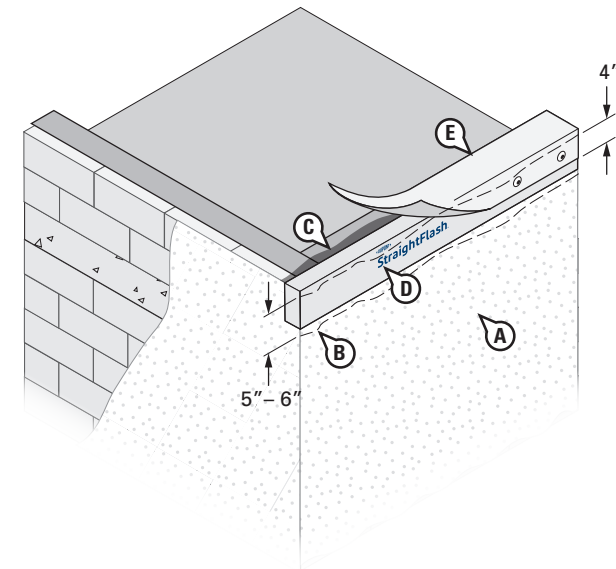

- A. Apply **Tyvek® Fluid Applied WB+™** prior to the installation of the **StraightFlash™** and parapet/roofing flashing membrane.
- B. Apply a wet bed of **Tyvek® Fluid Applied Product** onto the cured **Tyvek® Fluid Applied WB+™**. Wet bed application should extend 5"– 6" onto the cured **Tyvek® Fluid Applied WB+™** where **StraightFlash™** will be installed as a transition membrane prior the roofing membrane.
- C. Apply a *chemically-compatible adhesive/primer* to the top of wall where the **StraightFlash™** will be installed along the horizontal wall plane.
- D. Prepare and install 9' **StraightFlash™** for installation along the top of wall surfaces. Ensure 3"– 4" of **StraightFlash™** extends onto the primed horizontal wall plane and 5"– 6" onto the face of wall.
- E. Install parapet/roofing flashing membrane per manufacturer specifications. DuPont recommends extending the roofing membrane 4" onto the **StraightFlash™** transition membrane.

NOTE: As soon as practically possible, cap the top of wall system to reduce the likelihood of water intrusion into the wall cavity.

DuPont™ Tyvek® Fluid Applied WB+™ Installation Instructions

Continuity

Shelf Angle

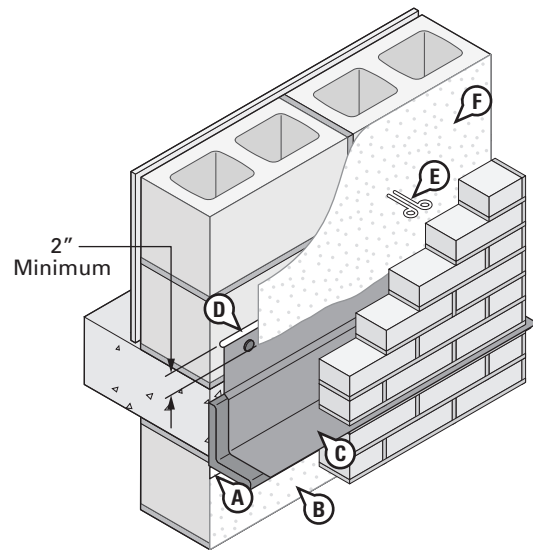

- A. Apply a bead of **DuPont™ Tyvek® Fluid Applied Flashing and Joint Compound+** along the underside of the metal angle and along the vertical wall surface. Use an inside corner trowel to spread material. Finished application should be approximately 60 mils thick and 2" wide on both surfaces. **NOTE:** **DuPont™ StraightFlash™** may be used to treat the interface between the wall and the through wall flashing. If **StraightFlash™** is used, the wall surface must be primed with a [chemically-compatible adhesive/primer](#) prior to installing the **StraightFlash™**. **StraightFlash™** must be installed 2" min onto both surfaces prior to **Tyvek® Fluid Applied WB+™**.
- B. Install **Tyvek® Fluid Applied WB+™** to wall surface below the shelf angle and onto the **Tyvek® Fluid Applied Flashing and Joint Compound+** or **StraightFlash™** (when used).
- C. Install self-adhered through wall flashing membrane (by others) with mechanical fasteners.

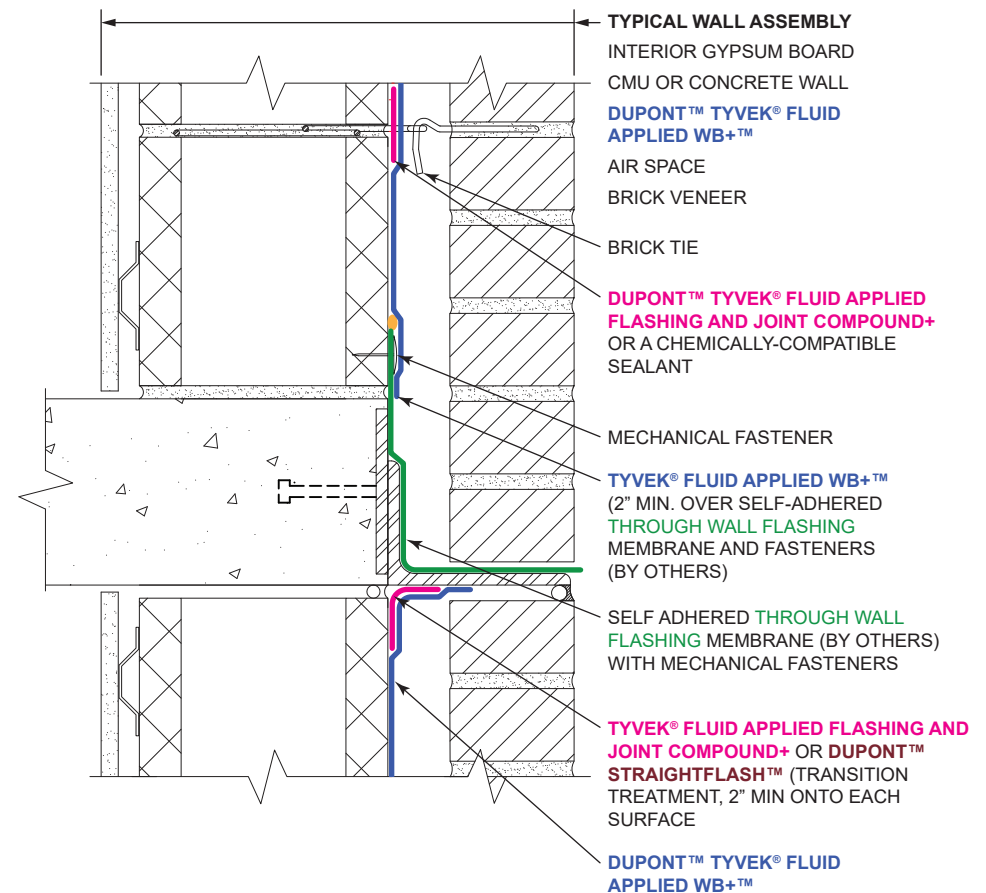

- D. Treat top edge of self-adhered through wall flashing with **Tyvek® Fluid Applied Flashing and Joint Compound+** or a [chemically-compatible sealant](#).
- NOTE:** **StraightFlash™** may be used to pretreat the interface between the wall and the through wall flashing.
- E. Pretreat embedded brick ties with **Tyvek® Fluid Applied Flashing and Joint Compound+**.
 - F. Apply **Tyvek® Fluid Applied WB+™**. Ensure membrane is continuous, free of pinholes and/or voids.

DuPont™ Tyvek® Fluid Applied WB+™ Installation Instructions

Continuity

Cantilevered Floor

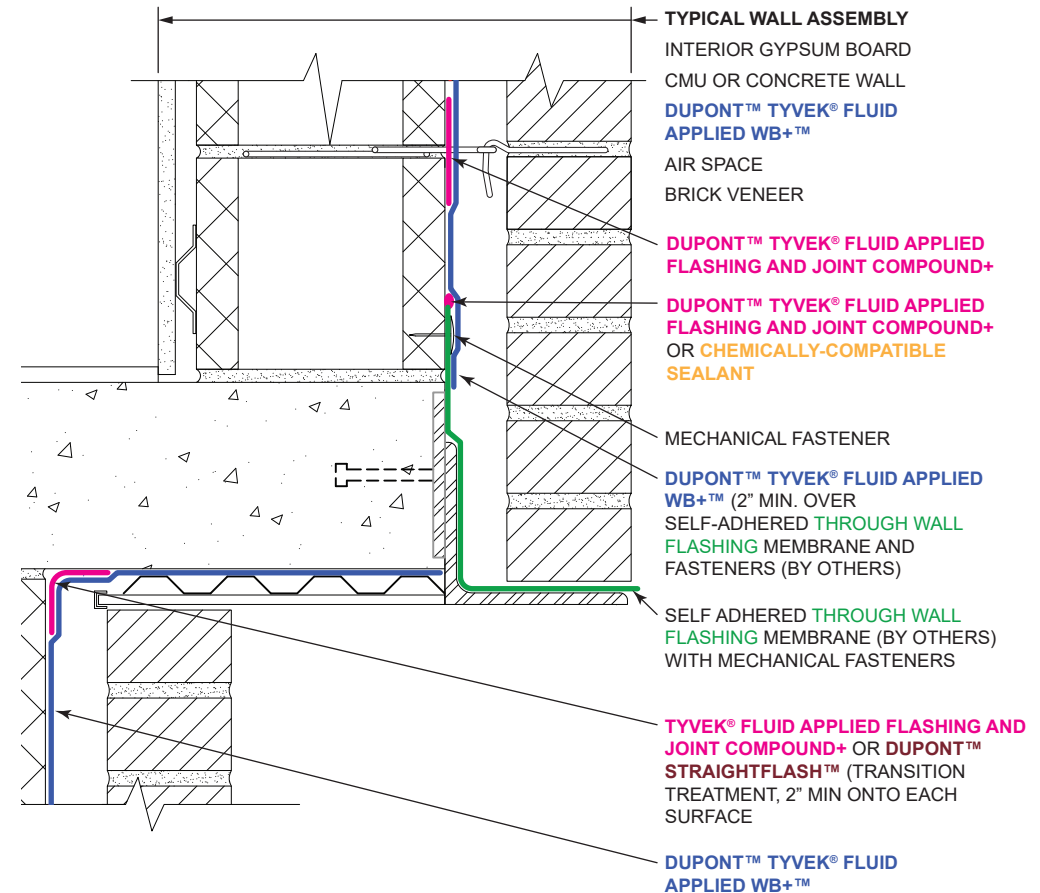
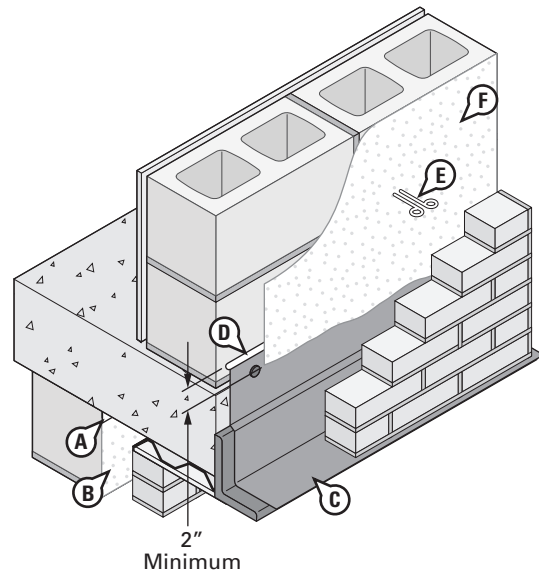

- A. Apply a bead of **DuPont™ Tyvek® Fluid Applied Flashing and Joint Compound+** along the underside of the metal angle and along the vertical wall surface. Use an inside corner trowel to spread material. Finished application should be approximately 60 mils thick and 2" min onto each surface. **NOTE:** **DuPont™ StraightFlash™** may be used to treat the interface between the wall and the through wall flashing. When **StraightFlash™** is used, the wall surface must be primed with a chemically-compatible adhesive/primer prior to **StraightFlash™**. **StraightFlash™** must be installed 2" min onto both surfaces prior to **Tyvek® Fluid Applied WB+™**.
- B. Install **Tyvek® Fluid Applied WB+™** to wall surface below the shelf angle, over the **Tyvek® Fluid Applied Flashing and Joint Compound+**, and along the underside of the concrete cantilever wall surface.

- C. Install self-adhered through wall flashing membrane (by others) with mechanical fasteners.
- D. Treat top edge of self-adhered through wall flashing with **Tyvek® Fluid Applied Flashing and Joint Compound+** or a chemically-compatible sealant.

NOTE: **StraightFlash™** may be used to pretreat the interface between the wall and the through wall flashing.

- E. Pre-treat embedded brick ties with **Tyvek® Fluid Applied Flashing and Joint Compound+**.
- F. Apply **Tyvek® Fluid Applied WB+™**. Ensure membrane is continuous, free of pinholes and/or voids.

DuPont™ Tyvek® Fluid Applied WB+™ Installation Instructions

Continuity

Inside Corner

Method 1: Using DuPont™ Tyvek® Fluid Applied Flashing and Joint Compound+

Application Option 1: Single Heavy Bead

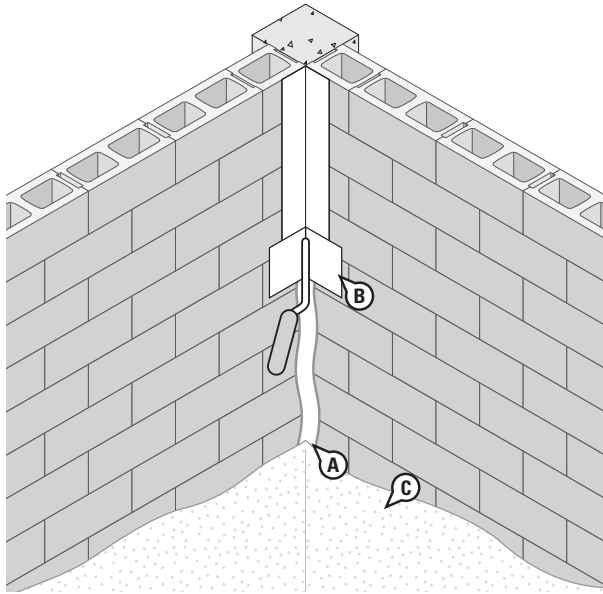

Application Option 2: Two Liberal Beads

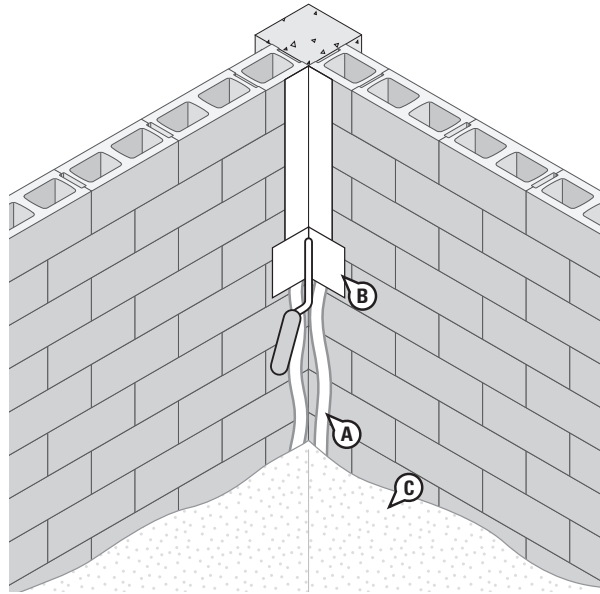

Application Option 3: S-Shaped Bead

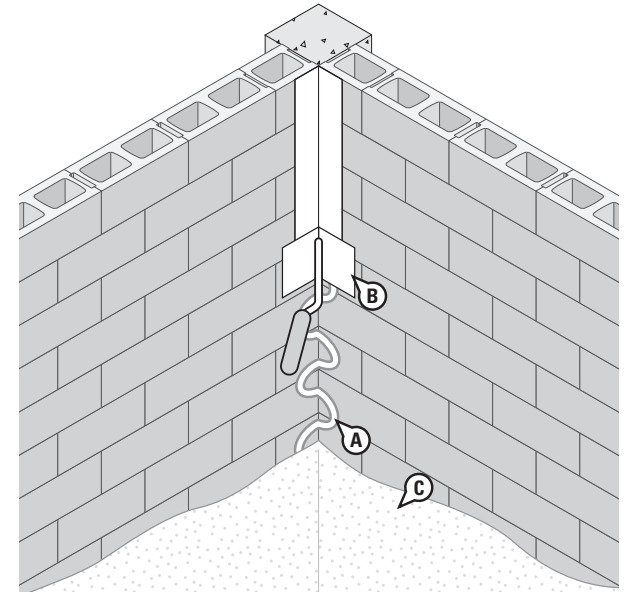

- A. Using one of the application options shown above, apply bead(s) of **Tyvek® Fluid Applied Flashing and Joint Compound+** along the inside corner area.
- B. Use inside corner trowel to create a continuous pinhole-free 25 mils thickness of **Tyvek® Fluid Applied Flashing and Joint Compound+**. Ensure **Tyvek® Fluid Applied Flashing and Joint Compound+** extends 2" onto the adjoining/adjacent wall surfaces.

NOTE: **Tyvek® Fluid Applied Flashing and Joint Compound+** can be applied by trowel or brush.

- C. Apply **Tyvek® Fluid Applied WB+™**. Ensure membrane is continuous, free of pinholes and/or voids.

DuPont™ Tyvek® Fluid Applied WB+™ Installation Instructions

Continuity

Inside Corner

Method 2: Using DuPont™ StraightFlash™

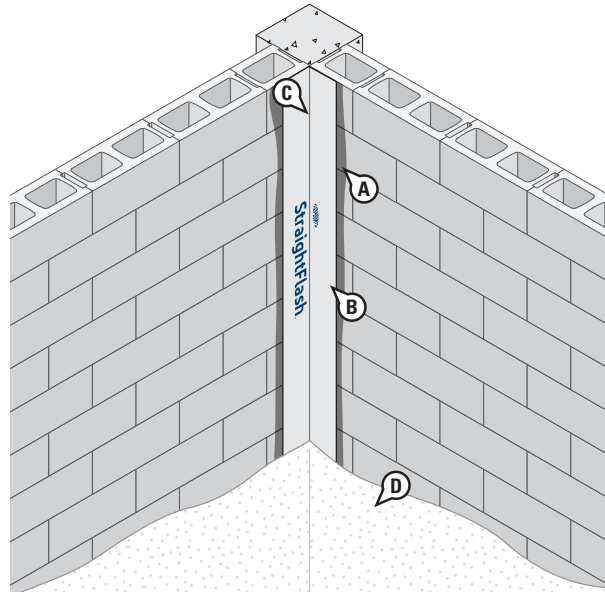

- A. Apply a [chemically-compatible adhesive/primer](#) along the inside corner. The primer application must extend onto the adjoining/adjacent wall surfaces to completely cover the area where the **StraightFlash™** will be installed.
- B. Cut the **StraightFlash™** the length of the intended application area.

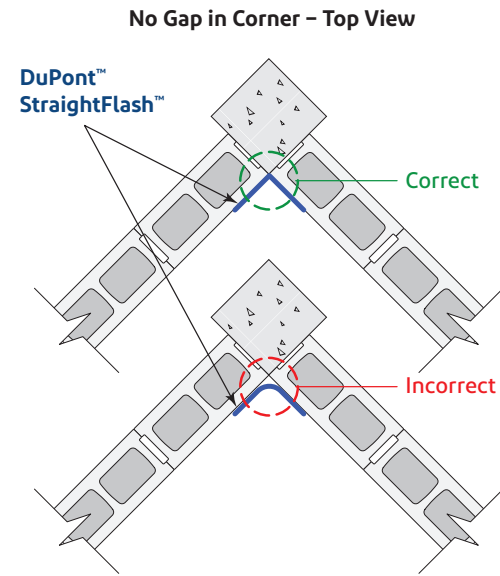

- C. Fold the **StraightFlash™** in half and crease to make inside corner application easier. Remove the release paper and install the **StraightFlash™** tightly into the inside corner without creating a radius, and fan out to the primed wall surfaces. The **StraightFlash™** should extend a min or 2" onto both wall surfaces.
- D. Apply **Tyvek® Fluid Applied WB+™**. Ensure **Tyvek® Fluid Applied WB+™** is continuous, free of pinholes and/or voids.

NOTE: When spraying, the outer edges of the **StraightFlash™** should be treated with **DuPont™ Tyvek® Fluid Applied Flashing and Joint Compound+** tapered to the wall substrate to help ensure installation is free of pinholes and voids.

DuPont™ Tyvek® Fluid Applied WB+™ Installation Instructions

Continuity

Outside Corner

Method 1*: Using DuPont™ Tyvek® Fluid Applied Flashing and Joint Compound+

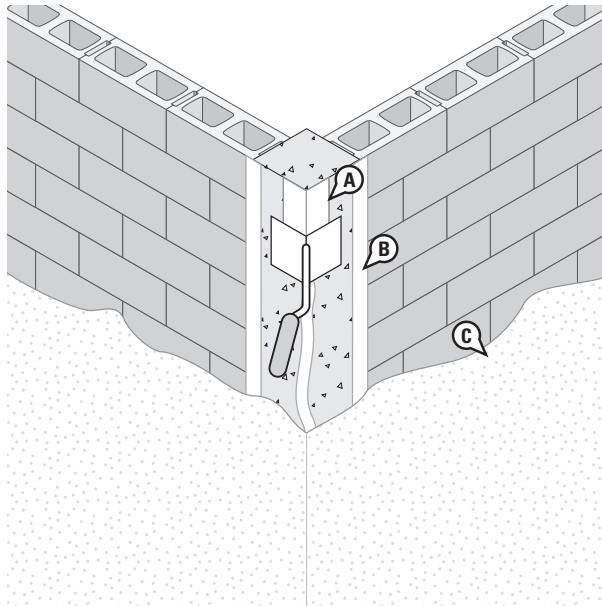

- A. Treat outside corner by applying a 25 mil thick coat of **Tyvek® Fluid Applied Flashing and Joint Compound+**, 2" onto each adjoining surface. It is recommended that a fillet bead of **Tyvek® Fluid Applied Flashing and Joint Compound+** be applied to corners to help ensure continuity. Alternately, corners may be treated using **DuPont™ StraightFlash™**. Be sure that the **StraightFlash™** is pressed tightly onto the corners and is fully adhered to primed wall substrate. See the [Special Considerations](#) section of this guide for priming requirements.
- B. Treat all non-moving transition joints to beams, columns, and dissimilar materials (up to 1/4") by applying a 2" wide, 60 mil thick coat of **Tyvek® Fluid Applied Flashing and Joint Compound+** across the joint. Grouted joints between similar materials do not need to be treated. Transition joints up to 1/2" should be reinforced with fiberglass mesh tape. **StraightFlash™** should be used for transition joints up to 1" following the primer requirements included in the [Special Considerations](#) section of this guide. The **StraightFlash™** should extend a minimum of 2" onto each surface. Refer to the [Joint Treatment Methods](#) section of this guide for additional information about transition joints.
- C. Apply **Tyvek® Fluid Applied WB+**. Ensure membrane is continuous, free of pinholes and/or voids.

Method 2*: Using DuPont™ StraightFlash™

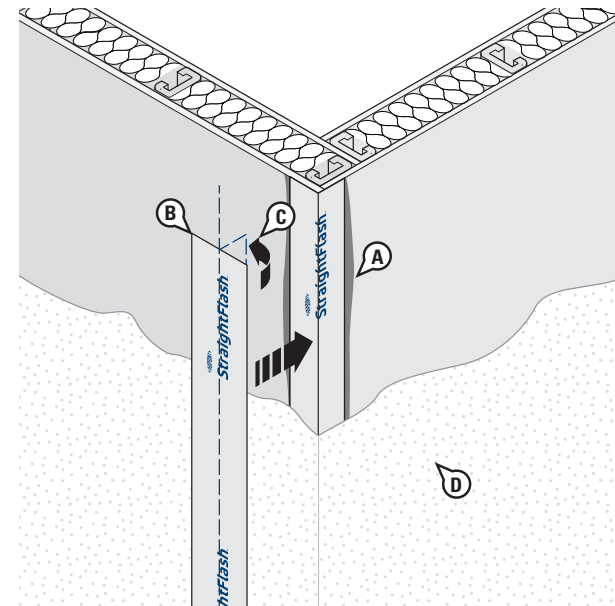

- A. Apply a [chemically-compatible adhesive/primer](#) to wall substrate where **StraightFlash™** will be installed.
- B. Cut **StraightFlash™** the length of the intended application area.
- C. Fold the **StraightFlash™** in half and crease to make inside corner application easier. Remove the release paper and install the **StraightFlash™** along the outside corner. **StraightFlash™** should extend a min or 2" onto both wall surfaces.
- D. Apply **Tyvek® Fluid Applied WB+™** onto wall surface at 25 mils thick. Ensure **Tyvek® Fluid Applied WB+™** is continuous, free of pinholes and/or voids.

NOTE: The Method 2 detail shows steel framing and exterior gypsum sheathing with **StraightFlash™** along the outside corner, but **Tyvek® Fluid Applied Flashing and Joint Compound+** can be used.

* For non-moving joints only.

DuPont™ Tyvek® Fluid Applied WB+™ Installation Instructions

Continuity

Transitions

Method 1*: Using DuPont™ Tyvek® Fluid Applied Flashing and Joint Compound+

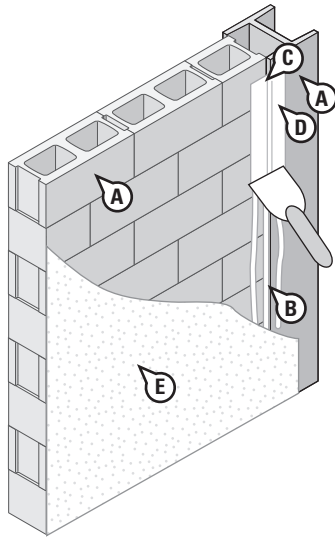

- A. Clean both substrates thoroughly. Remove any substance that could negatively affect adhesion.
- B. Fill seam between adjoining substrates flush with the surface using **Tyvek® Fluid Applied Flashing and Joint Compound+**. Joints up to 1/4" can be treated with **Tyvek® Fluid Applied Flashing and Joint Compound+** only. Joints from 1/4" to 1/2" should first be reinforced with fiberglass mesh tape or filled with mortar.
- C. Apply a bead of **Tyvek® Fluid Applied Flashing and Joint Compound+** to both adjoining surfaces and spread material across transition seam to a width of approximately 2"– 3" and 60 mils thick. Upon completion, inspect transition treatment for thin spots, gaps or pinholes and repair as necessary.
- D. Allow the **Tyvek® Fluid Applied Flashing and Joint Compound+** to form a tack-free skin before applying **DuPont™ Tyvek® Fluid Applied WB+™**. Refer to table in the [Drying/Curing](#) section of this installation guide for skin and working times.
- E. Apply **Tyvek® Fluid Applied WB+™** onto wall surface at 25 mils thick.

* For non-moving joints only.

Method 2*: Using DuPont™ StraightFlash™

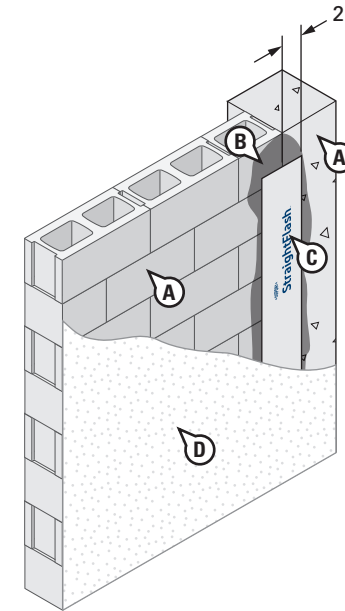

- A. Clean both substrates thoroughly. Remove any substance that could negatively affect adhesion.
- B. Prime both substrates using a [chemically-compatible adhesive/primer](#).
- C. Install **StraightFlash™** to the primed substrates, extending a minimum of 2" onto each surface. Press **StraightFlash™** firmly onto both surfaces, working it into any irregularities using a J-roller or firm hand pressure.
- D. Apply **Tyvek® Fluid Applied WB+™** onto wall surface at 25 mils thick.

NOTE: When spraying, the outer edges of **DuPont Self-Adhered Flashing Products** should be treated with **Tyvek® Fluid Applied Flashing and Joint Compound+** tapered to the wall substrate to help ensure installation is free of pinholes and voids.

* For non-moving joints only.

DuPont™ Tyvek® Fluid Applied WB+™ Installation Instructions

Continuity

Hybrid Wall – Transition to DuPont™ Tyvek® WRBs*

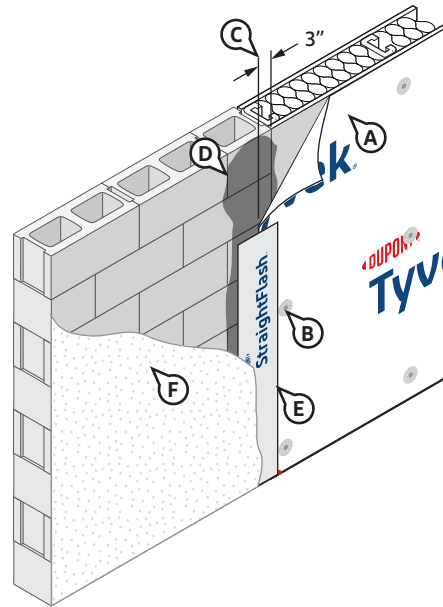

- A. Install **Tyvek® WRB** per the [DuPont™ Tyvek® Mechanically-Fastened Water-Resistive and Air Barrier \(WRB\) and DuPont Self-Adhered Flashing Products Installation Guidelines For Commercial and High-Performance Buildings of Any Height](#) prior to application of **DuPont™ Tyvek® Fluid Applied WB+™**.
- B. Fasten the **Tyvek® WRB** to the stud adjoining the transition substrate. Avoid placing **DuPont™ Tyvek® Wrap Cap Fasteners**, or recommended fasteners, where flashing will be installed; however, fasteners can be installed over the flashing.
- C. Cut the **Tyvek® WRB** so that approximately 3" will overlap the adjoining substrate.
- D. Fold back the 3" flap of **Tyvek® WRB** and prime adjoining substrate with a [chemically-compatible adhesive/primer](#).
- E. Fold the **Tyvek® WRB** back down over the interface and seal it to the primed substrate using **DuPont™ StraightFlash™**, overlapping both surfaces evenly by approximately 2". Apply pressure along entire surface of flashing. Refer to the [Special Considerations](#) section for additional information.

- F. Apply **Tyvek® Fluid Applied WB+™** onto wall surface, overlapping the **StraightFlash™** by a minimum of 2".

NOTE: Uncured **DuPont™ Tyvek® Fluid Applied Products** must not come in contact with **Tyvek® WRB** due to potential impact on performance properties. Therefore, use of a spray guard or other physical barrier to avoid overspray onto the **Tyvek® WRB** is recommended.

- G. Upon completion, inspect surface to ensure that **Tyvek® Fluid Applied WB+™** is continuous and free of any voids or pinholes.

NOTE: When spraying, the outer edge of **StraightFlash™** at the interface with the **Tyvek® Fluid Applied WB+™** should be treated with **DuPont™ Tyvek® Fluid Applied Flashing and Joint Compound+** tapered to the wall substrate to help ensure installation is free of pinholes and voids.

NOTE: This hybrid wall installation sequence is recommended when **Tyvek® WRB** is used with a competitive fluid applied membrane.

*The proper installation of DuPont Commercial **Tyvek® WRBs** (i.e. **DuPont™ Tyvek® CommercialWrap®** and **Tyvek® CommercialWrap® D**) with **Tyvek® Fluid Applied WB+™** provides a high-performance installation and offers [NFPA 285 compliant wall assemblies](#).

DuPont™ Tyvek® Fluid Applied WB+™ Installation Instructions

Continuity

Penetrations

Option 1: Using DuPont™ Tyvek® Fluid Applied Flashing and Joint Compound+

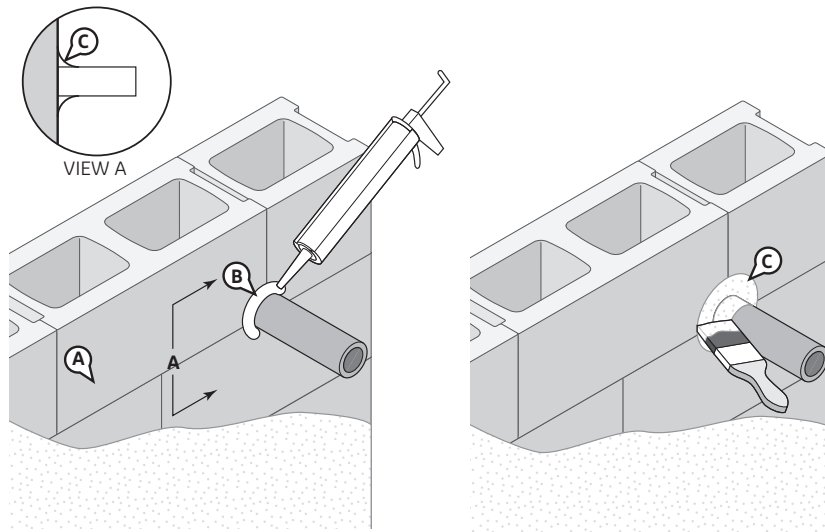

- Clean both substrates of any substance that could negatively affect adhesion and remove any sharp protrusions.
- Seal around the penetration using **Tyvek® Fluid Applied Flashing and Joint Compound+** and inserting a backer rod as necessary. Upon completion, inspect **DuPont™ Tyvek® Fluid Applied Product** for gaps or pinholes and repair as necessary.
- Brush **Tyvek® Fluid Applied Flashing and Joint Compound+** 1" minimum onto pipe and minimum 2" onto face of wall. Ensure application is at least 25 mils.

NOTE: Allow product to form a tack-free skin before applying **DuPont™ Tyvek® Fluid Applied WB+™** (refer to the [Drying/Curing](#) table for skin and working times).

Option 2: Using DuPont™ FlexWrap™ EZ for Non-Flanged Products with Outer Diameter (OD) GREATER Than 2 Inches*

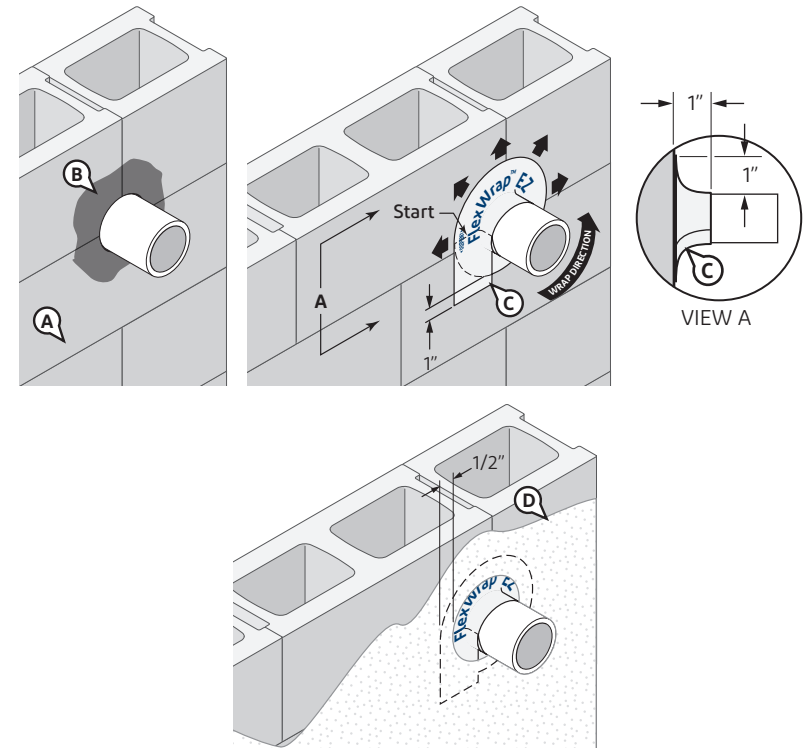

- Clean both substrates of any material that could negatively affect adhesion and remove any sharp protrusions.
- Apply a [chemically-compatible adhesive/primer](#) onto face of wall, around the opening.
- Seal around penetration with **FlexWrap™ EZ**. **FlexWrap™ EZ** should extend onto both surfaces by a minimum of 1", and also overlap the layer below by 1".
- Apply **Tyvek® Fluid Applied WB+™**, overlapping the **FlexWrap™ EZ** by 1/2" min.**
- *Use **FlexWrap™ EZ** only when the penetration rough opening is not more than 1/2" larger than the outside diameter/dimension of the non-flanged product.

When spraying, the outer edge of **FlexWrap™ EZ at the interface with the **Tyvek® Fluid Applied WB+™** should be treated with **Tyvek® Fluid Applied Flashing and Joint Compound+** tapered to the wall substrate to help ensure installation is free of pinholes and voids.

DuPont™ Tyvek® Fluid Applied WB+™ Installation Instructions

Continuity

Penetrations (continued)

Option 3: Using DuPont™ FlexWrap™ EZ for Non-Flanged Products with OD LESS Than 2 Inches*

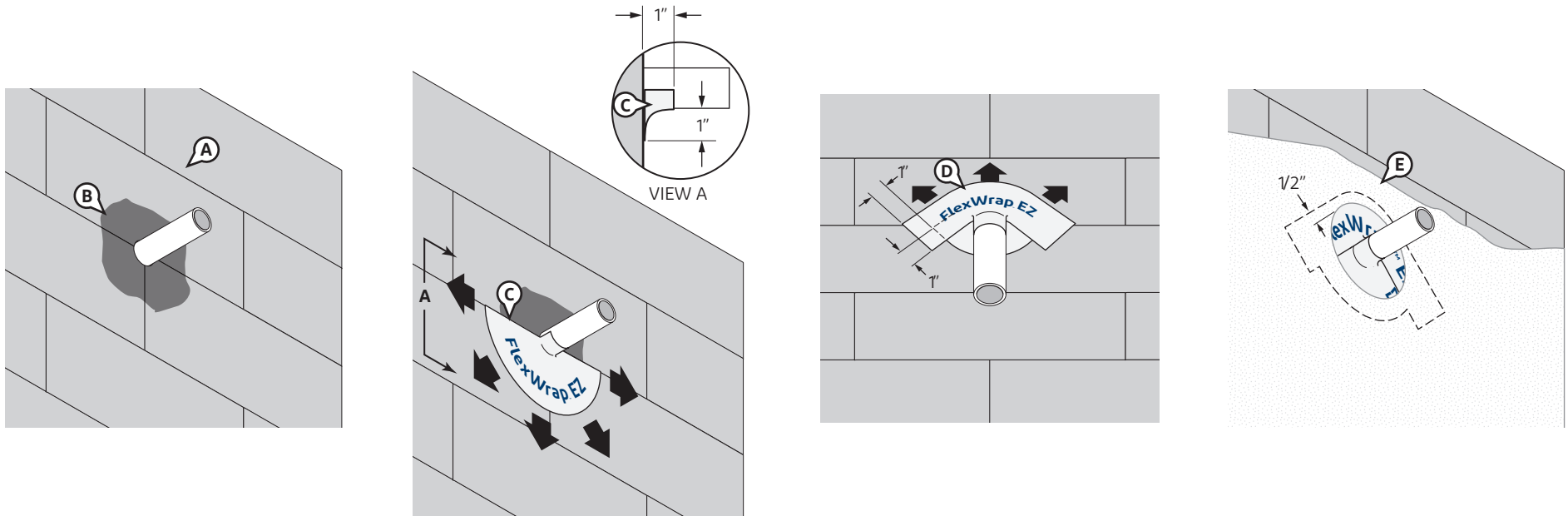

- A. Clean both substrates of any material that could negatively affect adhesion and remove any sharp protrusions.
- B. Apply a [chemically-compatible adhesive/primer](#) onto face of wall, around the opening.

- C. Adhere a piece of **FlexWrap™ EZ** the length of 1/2 the circumference of the non-flanged product onto bottom section, extending onto both surfaces by a minimum of 1" and fan out onto primed substrate.

- D. Adhere a second piece of **FlexWrap™ EZ** the length of the pipe circumference onto top section extending onto both surfaces by a minimum of 1" and fan out onto face of wall with a minimum of 1" overlap of the edges of **FlexWrap™ EZ** below.

- E. Apply **DuPont™ Tyvek® Fluid Applied WB+™**, overlapping the **FlexWrap™ EZ** by 1/2" min.**

*Use **FlexWrap™ EZ** only when the penetration rough opening is not more than 1/2" larger than the outside diameter/dimension of the non-flanged product.

When spraying, the outer edge of **FlexWrap™ EZ at the interface with the **DuPont™ Tyvek® Fluid Applied WB+™** should be treated with **DuPont™ Tyvek® Fluid Applied Flashing and Joint Compound+** tapered to the wall substrate to help ensure installation is free of pinholes and voids.

DuPont™ Tyvek® Fluid Applied WB+™ Installation Instructions

Continuity

Penetrations (continued)

Option 4: Using DuPont™ FlexWrap™

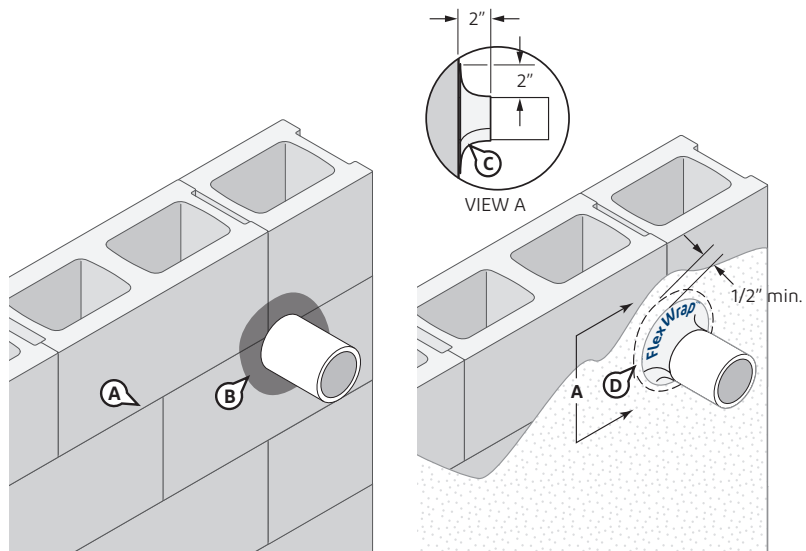

- A. Clean both substrates of any material that could negatively affect adhesion and remove any sharp protrusions.
- B. Apply a [chemically-compatible adhesive/primer](#) onto face of wall, around the opening.
- C. Seal around penetration with **FlexWrap™**. **FlexWrap™** should extend onto both surfaces by 2”.
- D. Apply **DuPont™ Tyvek® Fluid Applied WB+™**, overlapping the **FlexWrap™** by 1/2” min.*

NOTE: When spraying, the outer edge of **FlexWrap™** should be treated with **DuPont™ Tyvek® Fluid Applied Flashing and Joint Compound+** tapered to the wall substrate to help ensure installation of **Tyvek® Fluid Applied WB+™** is free of pinholes and voids.

Cladding/Facade Fastener Considerations

Brick Ties, Cladding Supports, and Furring Strips

As a best practice, DuPont recommends that all embedded masonry anchors be treated by brushing or troweling a coat of **Tyvek® Fluid Applied WB+™** or **Tyvek® Fluid Applied Flashing and Joint Compound+** around the base of the anchor.

When installing mechanically attached supports or furring strips in high-performance building envelope designs (building envelope design requirements exceeding ASTM E1677, and/or **when the designated water infiltration resistance is greater than (>) 3.14 psf, fasteners shall be sealed by:**

- Embedding support bracket or brick tie base plate into an additional wet bed of **DuPont™ Tyvek® Fluid Applied Product**
- Applying **DuPont™ StraightFlash™** patch over cured **Tyvek® Fluid Applied WB+™** at prescribed cladding fastener locations
- Applying a piece of double-sided butyl tape (by others) to the back of support bracket at fastener location
- An alternate DuPont-approved method.

NOTE: If using the **StraightFlash™** option, the patch may be placed in an additional wet bed of **Tyvek® Fluid Applied Product** to increase adhesion.

NOTE: When installing mechanically attached supports or furring strips in building envelope design requirements equivalent to ASTM E1677 conditions or less, and/or **when the designated water infiltration resistance is less than or equal to 3.14 psf (35mph), no pretreatment is necessary.**

Blind Sealing

When a fastener penetrates the air and water barrier that cannot be seen (i.e. **Tyvek® Fluid Applied WB+™** under exterior insulation). The following fasteners have been tested with **Tyvek® Fluid Applied WB+™** and are approved for use as “blind seal fasteners” without additional fastener treatment:

- Heckmann™ Posi-I-Tie® Brick Veneer Anchoring System
- Hohmann & Barnard, Inc. 2-Seal™ Ties
- TRUFAS™ Walls Grip-Deck Tube Seal™ Cap Fasteners
- TRUFAS™ Walls Thermal-Grip® MVA (Masonry Veneer Anchor)

DuPont™ Tyvek® Fluid Applied WB+™ Installation Instructions

Joint Treatment Methods*

When rolling or backrolling, joint treatment is not necessary for gaps 1/16" wide or less. When spraying, backrolling or joint pretreatment is required for gaps 1/16" wide or less. Upon completion of application, wall substrate should be free of pinholes and voids.

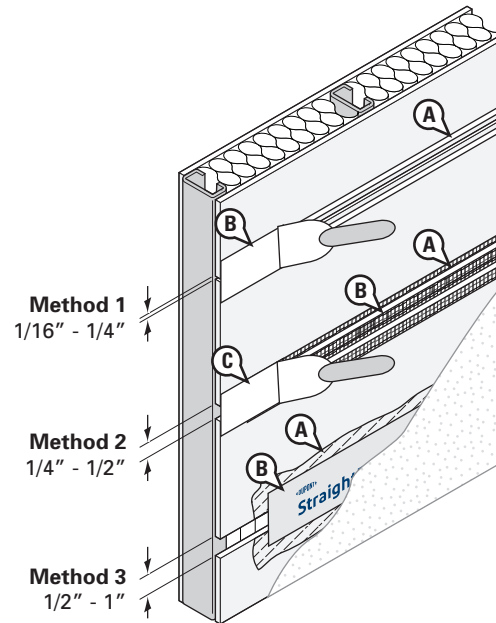

Method 1 (For Gaps Up to 1/4")

- Apply a bead of **DuPont™ Tyvek® Fluid Applied Flashing and Joint Compound+** above and below the sheathing seam.
- Trowel **Tyvek® Fluid Applied Flashing and Joint Compound+** across the joint to a smooth finish of 15 to 25 mils thick and extend a minimum of 1" on either side of the joint.

Optional Method (For Joints Up to 1/4")

Apply a bead **Tyvek® Fluid Applied Flashing and Joint Compound+** to both adjoining surfaces and spread material across transition seam to a width of approximately 2". Make sure the seam is filled. Scrape the **Tyvek® Fluid Applied Flashing and Joint Compound+** flush to the surface.

- Check joint for thin spots and pinholes, repair as necessary.
- Allow the **DuPont™ Tyvek® Fluid Applied Product** to form a tack-free skin before applying **DuPont™ Tyvek® Fluid Applied WB+™**. Refer to table in the [Drying/Curing](#) section of this installation guide for skin and working times.

Method 2 (For Gaps Up to 1/2")

- Firmly apply self-adhered reinforcing mesh tape.
- Apply a bead of **Tyvek® Fluid Applied Flashing and Joint Compound+** above and below the sheathing seam.
- Trowel **Tyvek® Fluid Applied Flashing and Joint Compound+** across the mesh tape to a smooth finish of 15 to 25 mils thick and extend a minimum of 1" on either side of the joint.
- Check joint for thin spots and pinholes, repair as necessary.

Method 3 (For Gaps Up to 1")

- Apply a [chemically-compatible adhesive/primer](#) above and below sheathing joint.
- Center **DuPont™ StraightFlash™** over joint and firmly press onto sheathing using a J-roller or firm hand pressure.

NOTE: When spraying, the outer edge of **DuPont™ StraightFlash™** should be treated with **Tyvek® Fluid Applied Flashing and Joint Compound+** tapered to the wall substrate to help ensure installation is free of pinholes and voids.

* For non-moving joints only.

DuPont™ Tyvek® Fluid Applied WB+™ Installation Instructions

Repair

Small repairs can be made by coating the damaged area with a layer of DuPont™ Tyvek® Fluid Applied Product. Larger damaged areas may need to be reinforced using fiberglass mesh or by replacing damaged substrate before reapplying Tyvek® Fluid Applied Product.

Equipment Recommendations

Tyvek® Fluid Applied WB+™ can be applied using a pressure roller or airless sprayer in conjunction with a variety of pumps, such as the Graco® Mark V, GMAX II 7900, IronMan 300E, IronMan 500G, GH 733, GH 833, GH 933, DutyMax GH675DI, or equivalent. All manufacturer limitations should be followed.

Roller Applied

Apply Tyvek® Fluid Applied WB+™ using a pressure roller with a 1/2" – 3/4" nap roller cover. **NOTE:** Some roller covers may have loose fibers at the start of use that may need to be worked off to limit and/or minimize loose fibers on the wall substrate.

Foam-type rollers and shorter naps **should not be used**, as they tend to slide across the wall substrate.

Spray Applied

Tyvek® Fluid Applied WB+™ can be spray applied using electric or gas hydraulic airless sprayers. Always ensure water is not present in the spray system prior to the introduction of Tyvek® Fluid Applied WB+™. A pre-flush of the sprayer with 100% mineral spirits is recommended.

A Graco® Silver Plus spray gun or a heavy duty texture gun along with Graco® RAC 5 or XHD-RAC tips are recommended for spray operations at temperatures above 70°F (21°C). The Graco® G-40 air assisted spray gun (with 90 psi at the spray tip) can be used to improve atomization when the Tyvek® Fluid Applied WB+™ temperature is between 65°F (18°C) and 70°F (21°C).

All internal filters should be removed from the pump, spray gun, and pressure roller assembly, before applying product. The pump intake screen should be installed when applying product. The condition of the pump, as well as the size, length, and condition of the hoses used can affect the systems performance.

The diameter of some hose sections may need to be increased, depending on the pumping distance desired. Refer to pump manufacturer's representative and guidelines regarding the operation and maintenance of the pump system. Operation of pump equipment can be hazardous. All manufacturer limitations, warnings, and safety recommendations should be followed.

When spraying Tyvek® Fluid Applied WB+ at low temperatures, the optimum hose configuration is 50' of 1/2" diameter hose in combination with a 50' section of 3/8" diameter hose. The maximum recommended hose length for spray operations is 100 ft. If site conditions require greater hose lengths, pressure rolling is recommended. **NOTE:** If using a whip for hose mobility, the diameter of the whip should be the same as the hose. For example, a 3/8" diameter whip should be used when connecting to a 3/8" diameter hose.

Please refer to the installation bulletin [Additional Considerations When Spraying DuPont™ Tyvek® Fluid Applied WB+™](#) for additional guidance when applying Tyvek® Fluid Applied WB+™ with an airless sprayer.

Installation Methods for DuPont Flashing Products

Key Installation Requirements for Drainable Window / Door Installation

When flashing windows or doors, the following principles must be followed:

- An integral flanged window/door is defined as a window/door unit with a nailing fin or flange that is continuous around the perimeter of the window and that is a direct extrusion of the window frame.
- Any window/door that has a nailing fin or flange that is **not continuous around the perimeter** of the window/door or the fin/flange is **not a direct extrusion of the frame** (e.g. field-applied flanges) is considered a **non-integral flanged unit**.
- When installed properly, **DuPont™ StraightFlash™** and **DuPont™ FlexWrap™** provide nail sealability at window/door openings to help protect critical window-wall interfaces. Metal sill pan flashing may be used, but must not replace flexible sill flashing that provides nail sealability.
- **DuPont Self-Adhered Flashing Products** comply with AAMA 711, *Voluntary Specification for Self Adhering Flashing Used for Installation of Exterior Wall Fenestration Products*, which has a modified version of ASTM D1970 and it is more representative for vertical wall applications.
- **DuPont™ Tyvek® Fluid Applied Flashing and Joint Compound+** complies with AAMA 714, *Voluntary Specification for Liquid Applied Flashing Used to Create a Water-Resistive Seal around Exterior Wall Openings in Buildings*.
- Ensure that sill flashing does not slope to the interior. An exterior slope is recommended, but not required.
- Direct water onto an acceptable air and water barrier drainage plane with an unobstructed path to the exterior of the wall. Provide a drainage path for any water intrusion through the window/door attachment system that collects at the sill.
- **DuPont Flashing Products** must be installed as captured within this guide to allow **DuPont™ Tyvek® Fluid Applied WB+™** to be properly integrated to ensure the continuity of the air and water barrier system. **DuPont Flashing Products** must be applied with a minimum 2" extension onto the face of wall substrate.
- DuPont requires **FlexWrap™**, **FlexWrap™ EZ**, **StraightFlash™**, and **Tyvek® Fluid Applied Flashing and Joint Compound+** be covered within nine months (270 days) of installation.
- Properly prepare all surfaces (remove dirt, dust, or moisture, etc.) per manufacturer's recommendations.
- Barrier installations (full perimeter seal on exterior) are acceptable only in the

following instances:

- Slab on grade doors, store front windows, or other systems with built-in drainage mechanisms that have potential for exposure to standing water
 - Surface barrier wall systems with non-water sensitive framing material (i.e., CMU walls)
 - Very low wind / rain exposure regions (southwest / desert) that follow AAMA 2400 installation guideline
- Ensure that window / door and flashing system design takes into account common factors that will impact performance, such as:
 - Climate considerations: Rainfall, Wind, Temperature (hot / cold cycles), Humidity
 - Building design: Window / Wall Design (overhangs, recessed openings, bump-outs), Wall Assembly (steel frame or masonry), Window System (non-flanged, storefront, curtain-wall, wood, or vinyl), Method of Attachment, New Construction or Replacement Window drainage path
 - UV exposure prior to the construction of the exterior facade
 - Compliance with fire resistance code requirements. For more information about NFPA 285 compliant wall assemblies utilizing **Tyvek® Fluid Applied WB+™** and **DuPont™ Tyvek® Mechanically-Fastened WRBs** visit building.dupont.com.
 - Field testing the window / door and wall installation as a complete system is a recommended best practice.
 - Use of trained installers is highly recommended. DuPont offers a DuPont™ Tyvek® Fluid Applied Certified Installer program. Please refer to the DuPont Sales Representative responsible for **DuPont™ Tyvek® Fluid Applied Products** in the project area for additional information.

Sealants and Adhesives/Primers

Review the manufacturers' literature or label to confirm that the product(s) used have the chemical and adhesive properties necessary for use with **Tyvek® Fluid Applied Products**, **DuPont Self-Adhered Flashing Products**, and **Tyvek® WRBs**. Ensure the sealant materials meet the installation temperature requirements of the sealant manufacturer. Refer to [Chemical Compatibility of Representative Building Sealants and Adhesives/Primers](#) for more information about chemical compatibility.

Installation Methods for DuPont Flashing Products

Storefront Window

Method 1: Using DuPont™ Tyvek® Fluid Applied Flashing and Joint Compound+ and DuPont™ StraightFlash™

The steps below for Methods 1, 2, and 3 can be used for the following conditions: Storefront Windows on Knee-Walls Storefront Windows on Slab*, Non-Flanged Windows and Non-Flanged Doors.

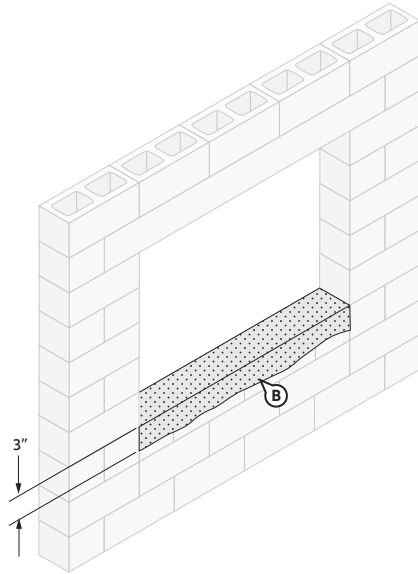

STEP 1

- Clean substrate of any material that could negatively affect adhesion as well as any sharp protrusions.
- Apply a [chemically-compatible adhesive/primer](#) to wall substrate area where sill flashing will be installed.

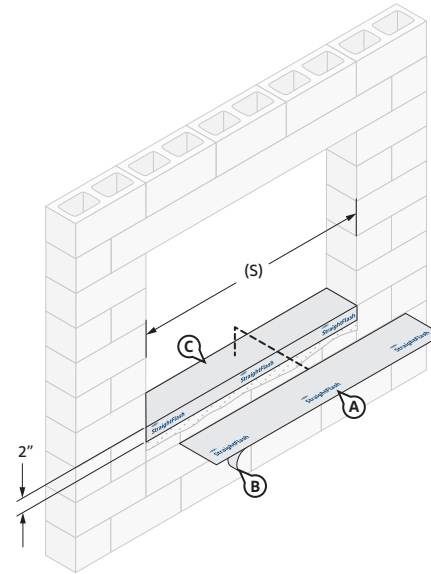

STEP 2

- Cut 9" **StraightFlash™** the width of rough opening sill (S). Ensure a minimum of 1" adhesion **BEYOND** where the back of the window frame will be located, and 2"– 3" adhesion onto the face of wall.
- Remove the release paper and position **StraightFlash™** onto the sill and 2" minimum onto the face of wall.
- Apply pressure along the entire surface of **StraightFlash™** for a good bond using firm hand pressure or J-roller (or alternate tool without sharp edges such as a plastic carpet tuck tool) to assist with application of uniform pressure.

NOTE: 9" **DuPont™ FlexWrap™** may be used to protect the sill and sill/jamb corners. If used, **FlexWrap™** installation along the sill should be aligned with [STEPS 2 and 3](#) of Method 2.

NOTE: Storefront Windows on Slab are not required to use **StraightFlash™**, **FlexWrap™** and/or **Tyvek® Fluid Applied Flashing and Joint Compound+** along the sill if a receiving unit or flashing components are required as part of storefront window manufacturer specifications.

Installation Methods for DuPont Flashing Products

Storefront Window

Method 1: Using DuPont™ Tyvek® Fluid Applied Flashing and Joint Compound+ and DuPont™ StraightFlash™

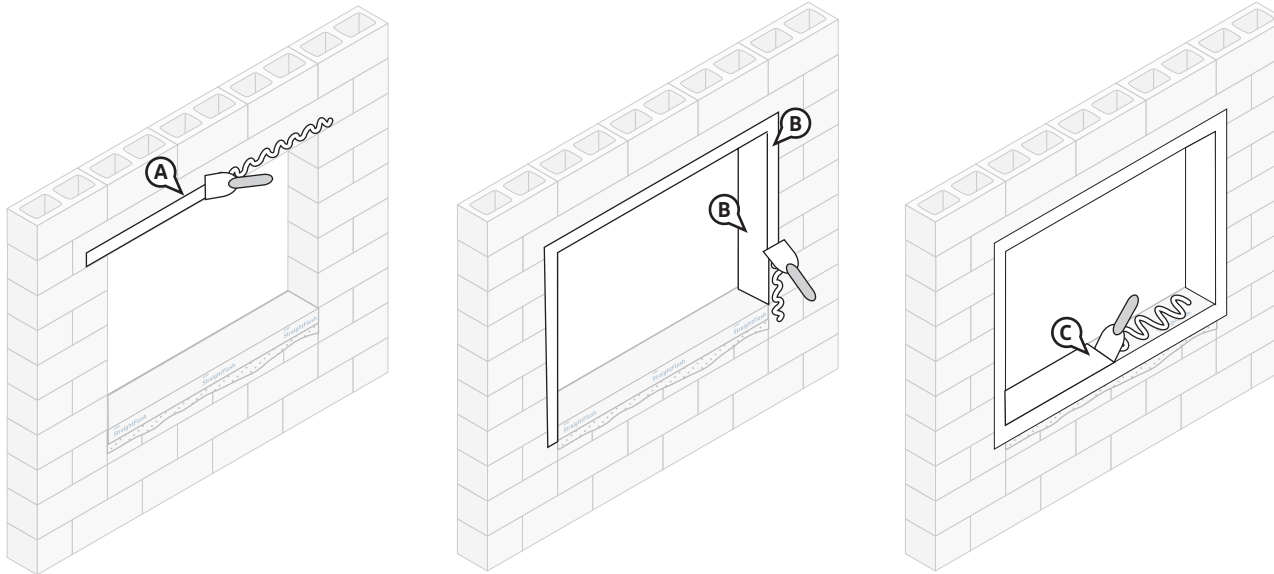

STEP 3

- A. Starting at the window head, apply **Tyvek® Fluid Applied Flashing and Joint Compound+** onto the inside surface of the rough opening and onto the face of wall. Use a trowel or brush to smooth out flashing to a thickness of approximately 25 mils. The flashing should cover the inside of the rough opening and extend a minimum of 2" onto the face of wall.
- B. Apply **Tyvek® Fluid Applied Flashing and Joint Compound+** along the rough opening of both jambs and minimum 2" onto the face of wall. Use a trowel or brush to smooth out flashing to a thickness of approximately 25 mils.

- C. Apply **Tyvek® Fluid Applied Flashing and Joint Compound+** on top of the **StraightFlash™** on the sill and a minimum 2" onto the face of wall. Be sure all inside corners are filled and integrated with the **StraightFlash™**. A corner trowel may be used to smooth outside corners.

NOTE: **Tyvek® Fluid Applied Flashing and Joint Compound+** is not required along the entire sill when **StraightFlash™** is installed as previously captured, provided **Tyvek® Fluid Applied Flashing and Joint Compound+** is applied a minimum 4"– 6" along the sill from the jamb corner.

NOTE: If **DuPont™ FlexWrap™** is used along the sill and a minimum of 6" up the jambs, **Tyvek® Fluid Applied Flashing and Joint Compound+** is not required along the sill to jamb interface but must be applied to head and jamb areas.

Installation Methods for DuPont Flashing Products

Storefront Window

Method 1: Using DuPont™ Tyvek® Fluid Applied Flashing and Joint Compound+ and DuPont™ StraightFlash™

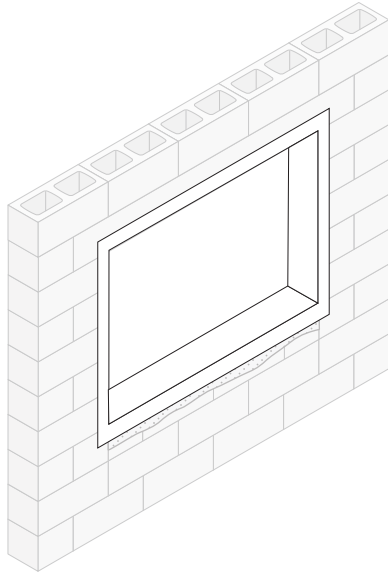

STEP 4

Upon completion, inspect surface, including all corners, to ensure that **Tyvek® Fluid Applied Flashing and Joint Compound+** is continuous and **free of any voids or pinholes**. **DuPont™ Tyvek® Fluid Applied WB+™** may be applied over and integrated with **Tyvek® Fluid Applied Flashing and Joint Compound+** once a tack-free skin has formed. Skin time is 1-2 hrs at 70°F (20°C), 50% RH.

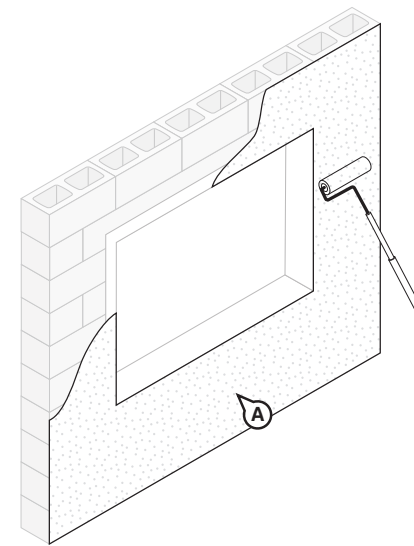

STEP 5

A. Install **Tyvek® Fluid Applied WB+™** up to the edge of the rough opening, overlapping the **Tyvek® Fluid Applied Flashing and Joint Compound+**.

NOTE: When spraying, the outer edge of **DuPont Self-Adhered Flashing Product** should be treated with **Tyvek® Fluid Applied Flashing and Joint Compound+** or **Tyvek® Fluid Applied WB+™** tapered to the wall substrate to help ensure installation is free of pinholes and voids.

Refer to the [DuPont™ Tyvek® Fluid Applied WB+™ Installation Instructions](#) section of this document. Exterior insulation and/or cladding may be installed once the membrane has cured sufficiently to resist damage during installation. Skin time is 1-2 hours, and 25 mil is workable in 24 hours at 70°F (20°C), 50% RH.

Installation Methods for DuPont Flashing Products

Storefront Window

Method 1: Using DuPont™ Tyvek® Fluid Applied Flashing and Joint Compound+ and DuPont™ StraightFlash™

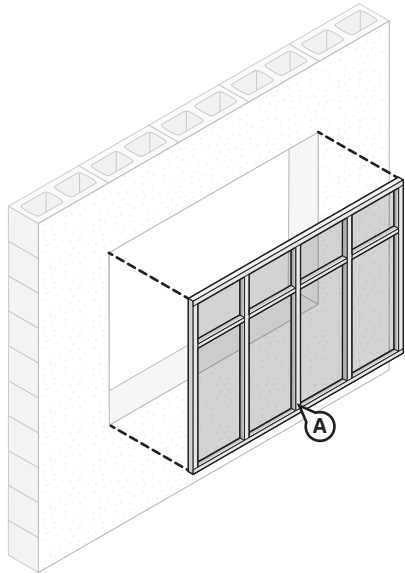

STEP 6

A. Install window per manufacturer's installation instructions.

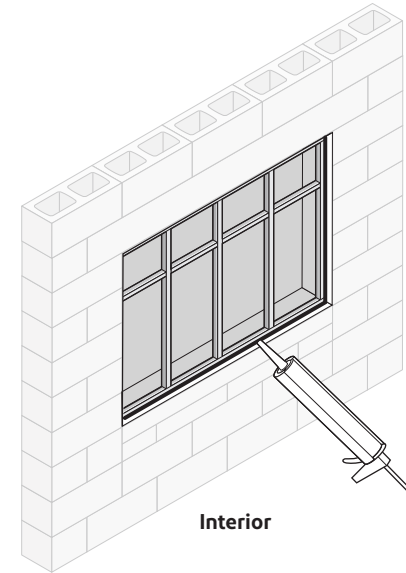

STEP 7

Create Interior Perimeter Seal

Apply a continuous bead of a [chemically-compatible sealant](#) (and backer rod as necessary) around the window opening at the interior. It is also acceptable to use **Great Stuff Pro™ Window & Door Polyurethane Foam Sealant**, or a chemically-compatible foam. When using **Great Stuff Pro™ Window & Door Polyurethane Foam Sealant** in perimeter openings less than 1/2", apply using the plastic extension tip for the **Great Stuff Pro™ Dispensing Gun** during installation.

NOTE: For high performance installations exceeding ASTM E1677 wind loading pressures (10.8 psf, 65 mph equivalent structural load) and ASTM E331 water infiltration resistance of 6.24 psf, a chemically-compatible sealant **must be** installed over the cured foam when using **Great Stuff Pro™ Window and Door Polyurethane Foam Sealant** or a chemically-compatible foam. Sealant should be installed over the foam between the window frame and rough opening around the entire interior perimeter. If **Great Stuff Pro™ Window and Door Polyurethane Foam Sealant** or other chemically-compatible foam extends beyond the window frame, shave the excess cured foam flush with the window frame before applying sealant. Avoid damaging the **DuPont™ Tyvek® Fluid Applied Flashing and Joint Compound+** and/or **DuPont Self-Adhered Flashing Products**.

NOTE: Refer to the *Storefront Window* CAD details at building.dupont.com for more detailed information.

Installation Methods for DuPont Flashing Products

Storefront Window

Method 2: Self-Adhered Flashing Using DuPont™ FlexWrap™ and DuPont™ StraightFlash™

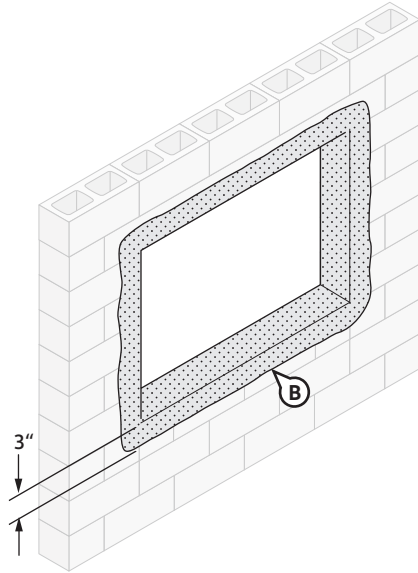

STEP 1

- A. Clean substrate of any material that could negatively affect adhesion, as well as any sharp protrusions.
- B. Apply a [chemically-compatible adhesive/primer](#) approximately 3" onto the exterior face of wall and onto the inside perimeter of the rough opening for masonry and concrete surfaces.

Installation Methods for DuPont Flashing Products

Storefront Window

Method 2: Self-Adhered Flashing Using DuPont™ FlexWrap™ and DuPont™ StraightFlash™

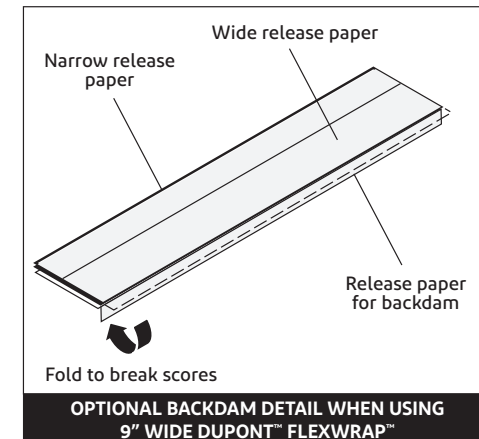
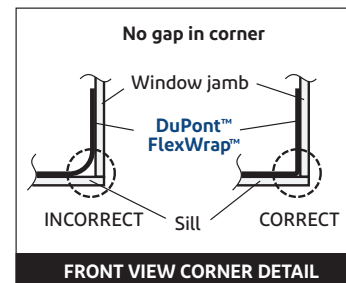
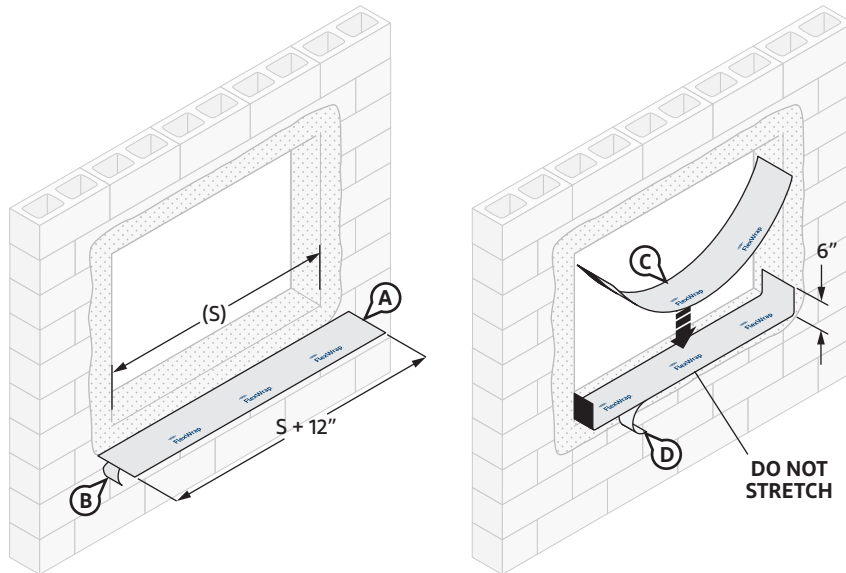

STEP 2

- Cut **FlexWrap™** at least 12" **LONGER** than the width of rough opening sill (S). Use roll widths sufficient to achieve a minimum of 1" adhesion **BEYOND** where the back of the window frame will be located, ensuring 2"– 3" adhesion onto the face of wall.
- Remove wide piece of release paper.
- Position **FlexWrap™** along the sill by aligning the inside of the narrow release paper with the face of wall to ensure 2"– 3" adhesion to face of wall with a minimum of 6" up each jamb. Adhere into rough opening.

Optional Back Dam: Fold 9" **FlexWrap™** to break perforation. Remove center piece of release paper. Cover horizontal sill to accommodate back dam as appropriate, and adhere into rough opening along sill and up jambs (min 6" on each side). Leave 1" release paper on **FlexWrap™** inside rough opening to finish back dam after window installation.

NOTE: Use of the optional back dam **must not** interfere with the installation of a continuous interior perimeter seal.

- Remove the remaining release paper.

NOTE: DuPont™ Tyvek® Commercial Certified Installers may install a 3-piece head (and sill) detail for window openings less than 6 ft wide. Installers who **are not** DuPont™ Tyvek® Commercial Certified Installers should refer to the [Special Considerations](#) section for more information regarding the 3-piece head/sill detail. Contact your local DuPont Building Envelope Specialist for more information about the Certified Installer program.

Installation Methods for DuPont Flashing Products Storefront Window

Method 2: Self-Adhered Flashing Using DuPont™ FlexWrap™ and DuPont™ StraightFlash™

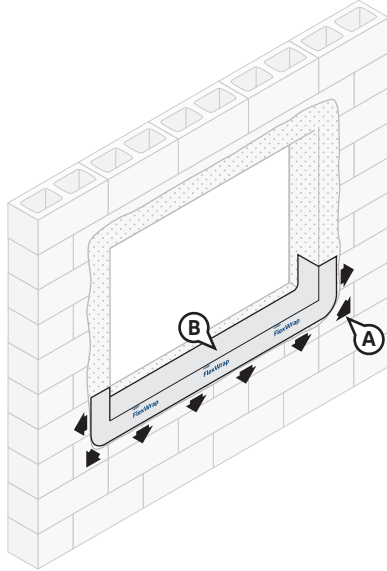

STEP 3

- A. Fan out the **FlexWrap™** at corners and adhere onto face of wall. Continue adhering onto face of wall along sill.
- B. Firmly press sill flashing to ensure full adhesion on all surfaces. Eliminate wrinkles and bubbles by smoothing surface and repositioning as necessary.

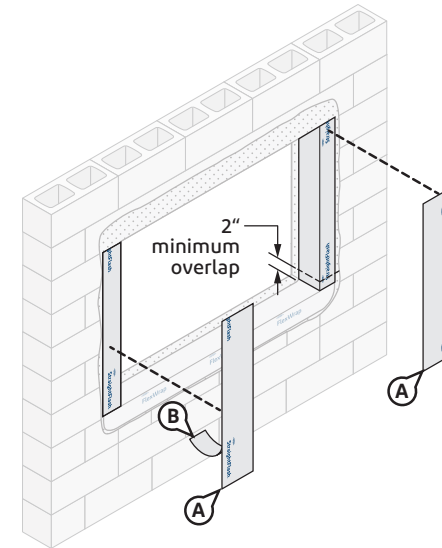

STEP 4

- A. Cut two jamb-length pieces of 9" **StraightFlash™**. Jamb flashing should overlap the sill flashing by at least 2".
- B. Remove release paper and position **StraightFlash™** so that 2"–3" extend onto the face of wall. Wrap jamb flashing into the rough opening at each jamb and onto face of wall. Apply pressure along entire surface of flashing for a good bond using firm hand pressure, J-roller, or alternate tool without sharp edges (such as a plastic carpet tuck tool) to assist with application of uniform pressure during installation of **DuPont Self-Adhered Flashing Products**. Eliminate wrinkles and bubbles by smoothing surface.

Installation Methods for DuPont Flashing Products

Storefront Window

Method 2: Self-Adhered Flashing Using DuPont™ FlexWrap™ and DuPont™ StraightFlash™

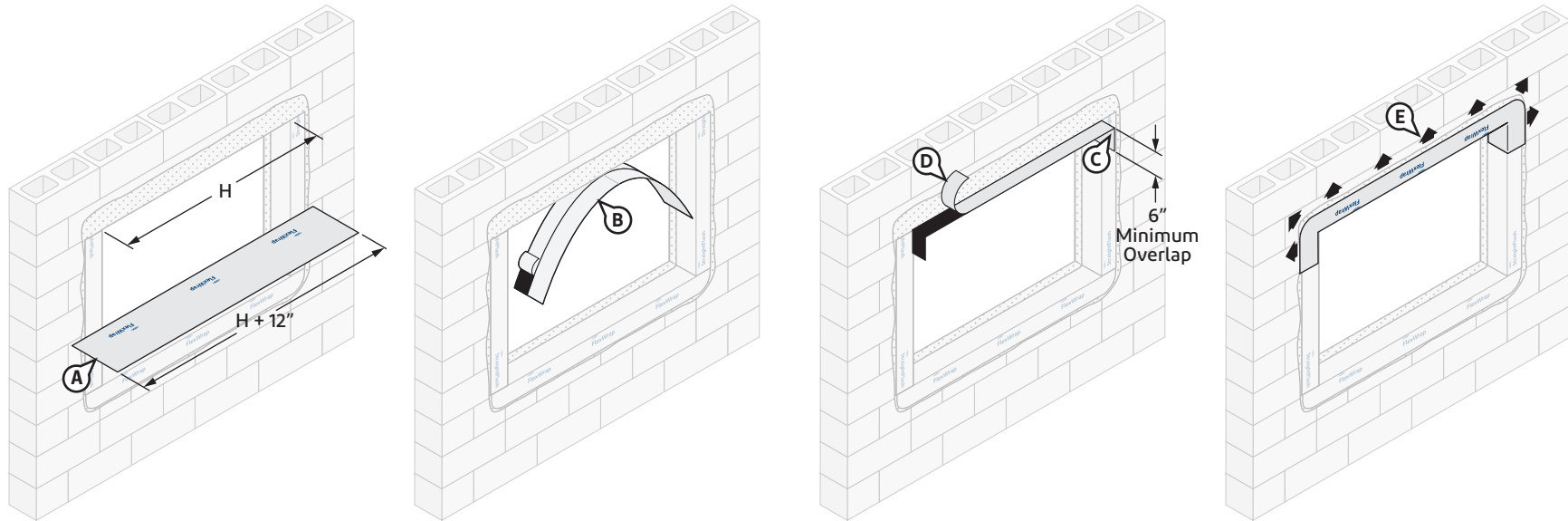

STEP 5

- Cut **FlexWrap™** at least 12" **LONGER** than the width of rough opening head (H). Use roll widths sufficient to achieve a minimum of 1" adhesion **BEYOND** where the back of the window frame will be located, ensuring 2"– 3" adhesion onto the face of wall.
- Fold the **FlexWrap™** in half lengthwise to create a slight crease at the center. Remove the wide piece of release paper on one side of the fold. Align the inside edge of the narrow release paper with the face of wall to ensure 2"– 3" adhesion to the face of wall.
- Starting at the crease, adhere the exposed butyl adhesive to the center of the head and a minimum of 6" down the jamb. Remove the remaining release paper and continue process of adhering **FlexWrap™** along the head of the rough opening and the opposite jamb.
- Remove remaining release paper.
- Fan out the **FlexWrap™** at corners and adhere onto the face of wall along the head.

NOTE: DuPont™ Tyvek® Commercial Certified Installers may install a 3-piece head (and sill) detail for window openings less than 6 ft wide. Installers who **are not** DuPont™ Tyvek® Commercial Certified Installers should refer to the [Special Considerations](#) section for more information regarding the 3-piece head/sill detail. Contact your local DuPont Building Envelope Specialist for more information about the Certified Installer program.

Installation Methods for DuPont Flashing Products

Storefront Window

Method 2: Self-Adhered Flashing Using DuPont™ FlexWrap™ and DuPont™ StraightFlash™

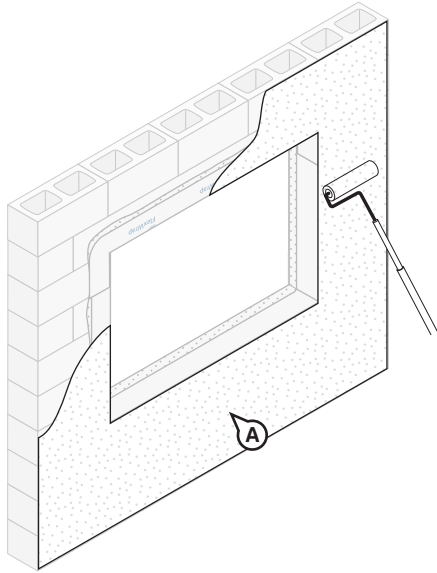

STEP 6

- A. Install **DuPont™ Tyvek® Fluid Applied WB+™** onto wall at 25 mils thick. Upon completion, inspect all surfaces to ensure that they are covered and **free of any voids or pinholes**.

NOTE: When spraying, the outer edge of **DuPont Self-Adhered Flashing Product** should be pretreated with a **DuPont™ Tyvek® Fluid Applied Product**, and tapered to wall substrate to help ensure installation is free of pinholes and voids.

Refer to the [DuPont™ Tyvek® Fluid Applied WB+™ Installation Instructions](#) section of this document. Exterior insulation and/or cladding may be installed once the membrane has cured sufficiently to resist damage during installation. Skin time is 1-2 hours, and 25 mil is workable in 24 hours at 70°F (20°C), 50% RH.

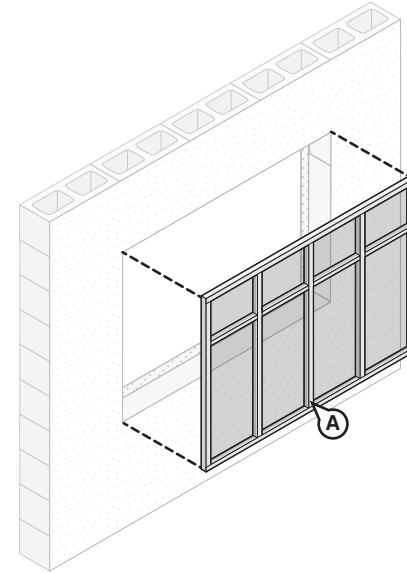

STEP 7

- A. Install window per manufacturer's installation instructions.

Installation Methods for DuPont Flashing Products

Storefront Window

Method 2: Self-Adhered Flashing Using DuPont™ FlexWrap™ and DuPont™ StraightFlash™

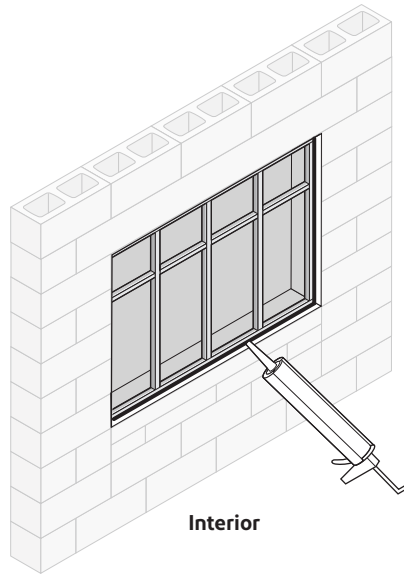

STEP 8

Create Interior Perimeter Seal

Apply a continuous bead of a [chemically-compatible sealant](#) (and backer rod as necessary) around the window opening at the interior. It is also acceptable to use **Great Stuff Pro™ Window & Door Polyurethane Foam Sealant**, or a chemically-compatible foam. When using **Great Stuff Pro™ Window & Door Polyurethane Foam Sealant** in perimeter openings less than 1/2", apply using the plastic extension tip for the **Great Stuff Pro™ Dispensing Gun** during installation.

NOTE: For high performance installations exceeding ASTM E1677 wind loading pressures (10.8 psf, 65 mph equivalent structural load) and ASTM E331 water infiltration resistance of 6.24 psf, a chemically-compatible sealant **must be** installed over the cured foam when using **Great Stuff Pro™ Window and Door Polyurethane Foam Sealant** or a chemically-compatible foam. Sealant should be installed over the foam between the window frame and rough opening around the entire interior perimeter. If **Great Stuff Pro™ Window and Door Polyurethane Foam Sealant** or other chemically-compatible foam extends beyond the window frame, shave the excess cured foam flush with the window frame before applying sealant. Avoid damaging the **DuPont™ Tyvek® Fluid Applied Flashing and Joint Compound+** and/or **DuPont Self-Adhered Flashing Products**.

NOTE: Refer to the Storefront Window CAD details at building.dupont.com for more detailed information.

Installation Methods for DuPont Flashing Products

Storefront Window

Method 3: Alternate Self-Adhered Flashing Option Using DuPont™ StraightFlash™ Only

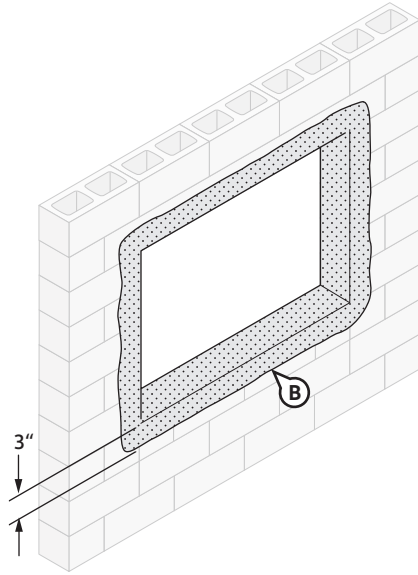

STEP 1

- A. Clean substrate of any material that could negatively affect adhesion, as well as any sharp protrusions.
- B. Apply a *chemically-compatible adhesive/primer* approximately 3" onto the exterior wall face and onto the inside perimeter of the rough opening for masonry and concrete surfaces.

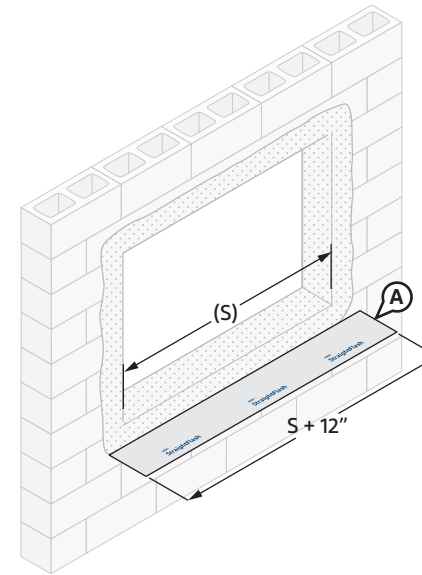

STEP 2

- A. Cut a piece of 9" **StraightFlash™** the length of the sill (S) plus an additional 12"

Installation Methods for DuPont Flashing Products

Storefront Window

Method 3: Alternate Self-Adhered Flashing Option Using DuPont™ StraightFlash™ Only

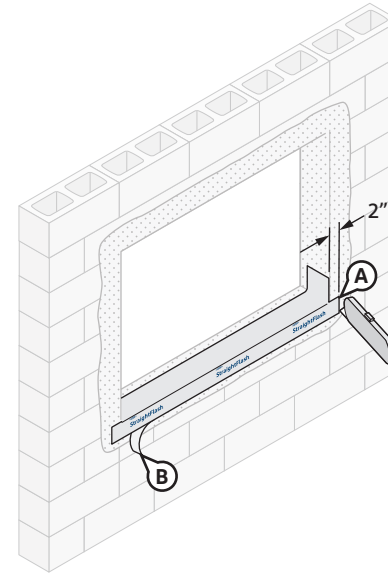
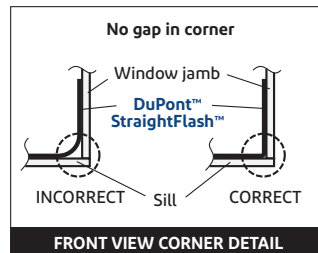
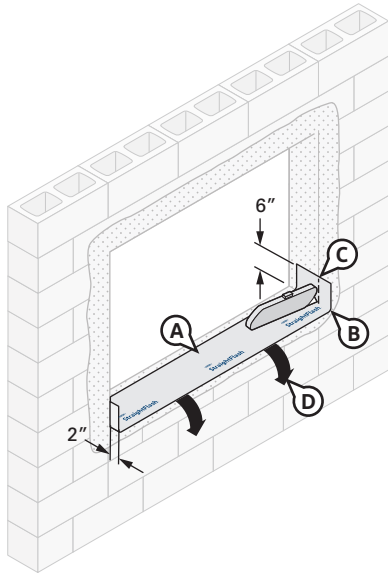

STEP 3

- Install the **StraightFlash™** by removing the widest strip of release paper, and aligning the flashing so it extends 1" **BEYOND** where the back of the window frame would be located, a minimum of 2" onto the face of wall, and 6" up the jambs.
- Secure flashing tightly into the corners by first working it in along the sill before adhering it up the jambs. (See front view corner detail below).
- Cut the jamb portion of the sill flashing even with the face of wall.
- With release paper still attached, fold flashing down onto the face of wall.

STEP 4

- Flaps created from vertical cuts in **StraightFlash™** should be trimmed so they do not extend more than 2" beyond jamb rough opening onto the face of wall.
- Remove remaining release paper and firmly press flashing onto the face of wall.

Installation Methods for DuPont Flashing Products

Storefront Window

Method 3: Alternate Self-Adhered Flashing Option Using DuPont™ StraightFlash™ Only

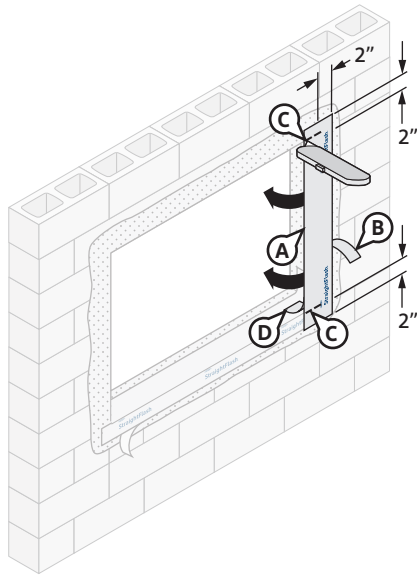

STEP 5

- Prepare the jamb flashing by cutting two pieces of **StraightFlash™** that are 4" longer than the jamb length.
- Remove the 2" wide portion of the release paper. Place the flashing onto the face of wall so that it extends a minimum of 2" past the jamb, head, and sill of the rough opening.
- Cut the **StraightFlash™** along the head and the sill of the rough opening. Flaps created from horizontal cuts in **StraightFlash™** should be trimmed so they do not extend more than 2"– 3" along the face of wall.
- Remove the remaining release paper. Fold the flashing into the rough opening and adhere it to the jamb.

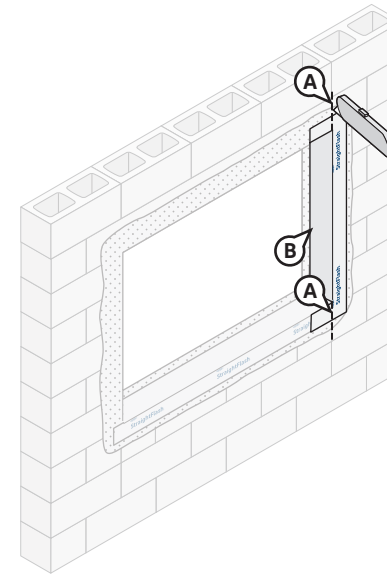

STEP 6

- Cut vertically along the remaining release paper and remove the excess flashing from the head and the sill.
- Apply firm pressure along the entire surface to ensure full adhesion on all surfaces.
- Install second piece of **StraightFlash™** to opposite jamb.

Installation Methods for DuPont Flashing Products

Storefront Window

Method 3: Alternate Self-Adhered Flashing Option Using DuPont™ StraightFlash™ Only

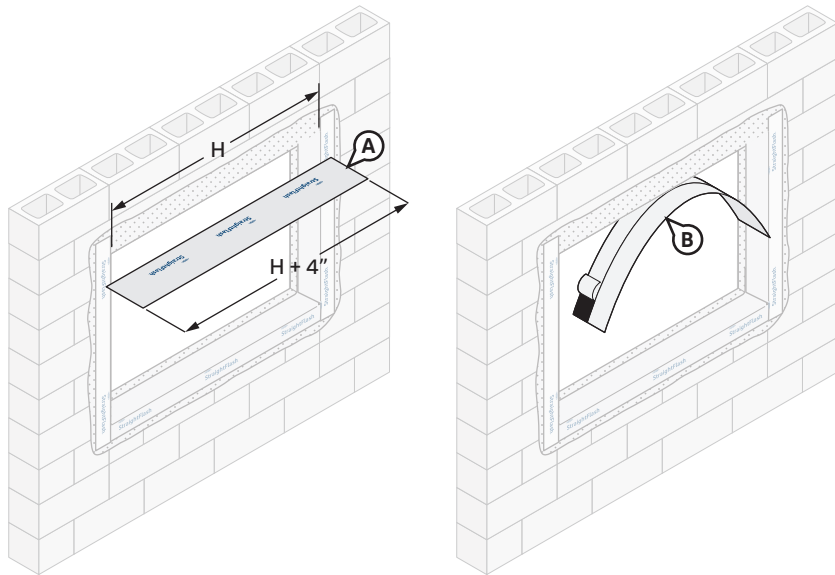

STEP 7

- A. Prepare the head flashing by cutting a piece of **StraightFlash™** that is at least 4" longer than the length of the rough opening head (H).
- B. Remove wide piece of release paper and position **StraightFlash™** underneath the head of the rough opening.

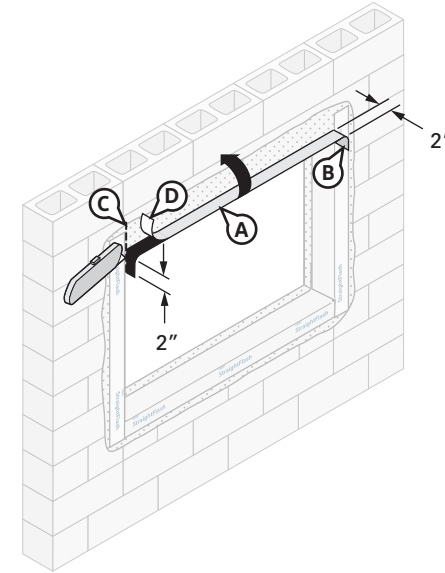

STEP 8

- A. Install the **StraightFlash™** by aligning the flashing so it extends 1" **BEYOND** where the back of the window frame will be located, 2"- 3" onto the face of wall, and 2" onto jamb flashing.
- B. Secure flashing tightly into the corners by first working it in along the head before adhering it down the jambs.
- C. Cut the jamb portion of the head flashing even with the face of wall.
- D. Remove the remaining release paper, fold the flashing up, and firmly press **StraightFlash™** onto the face of wall and jamb flashing overlaps. Apply pressure along entire surface of **StraightFlash™** for a good bond using firm hand pressure, J-roller, or alternate tool without sharp edges (such as a plastic carpet tuck tool) to assist with application of uniform pressure.

Installation Methods for DuPont Flashing Products

Storefront Window

Method 3: Alternate Self-Adhered Flashing Option Using DuPont™ StraightFlash™ Only

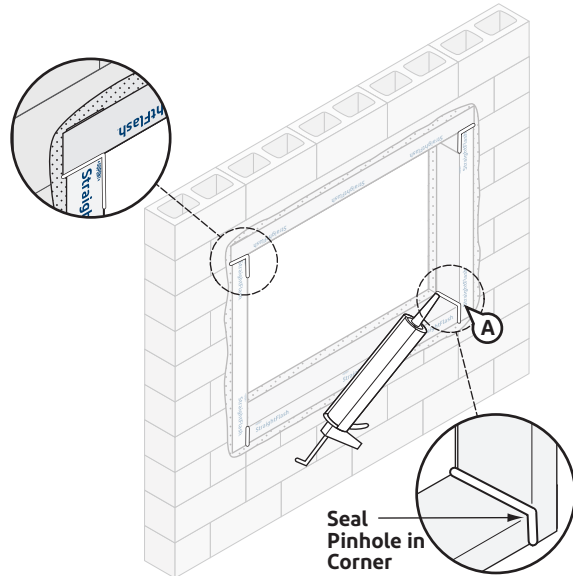

STEP 9

- A. Seal all four inside corners with **DuPont™ Tyvek® Fluid Applied Flashing and Joint Compound+**. Extend sealant onto the face of wall flashing.

NOTE: Be sure that the pinholes in the flashing corners are fully covered with sealant.

NOTE: **DuPont™ Tyvek® Fluid Applied Products** may be overcoated once a tack-free skin has formed. Skin time is 1-2 hrs at 70°F (20°C), 50% RH.

STEP 10

- A. Install **DuPont™ Tyvek® Fluid Applied WB+™** onto wall at 25 mils thick up to the edge of the rough opening, overlapping the **DuPont Self-Adhered Flashing Product**. Upon completion, inspect all surfaces to ensure that they are covered and **free of any voids or pinholes**.

NOTE: When spraying, the outer edge of **DuPont Self-Adhered Flashing Product** should be treated with **Tyvek® Fluid Applied Flashing and Joint Compound+**, and tapered to wall substrate to help ensure installation is free of pinholes and voids.

Refer to the [DuPont™ Tyvek® Fluid Applied WB+™ Installation Instructions](#) section of this document. Skin time is 1-2 hours, and 25 mils is workable in 24 hours at 70°F (20°C), 50% RH.

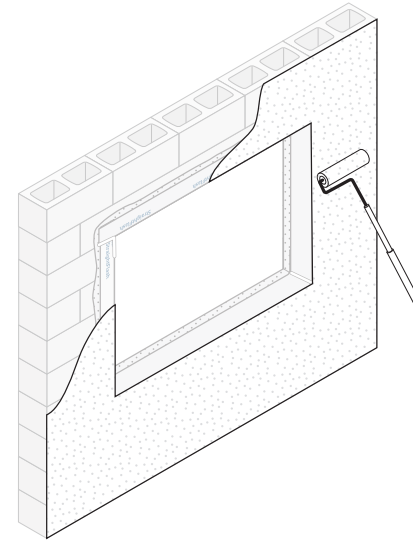

Installation Methods for DuPont Flashing Products

Storefront Window

Method 3: Alternate Self-Adhered Flashing Option Using DuPont™ StraightFlash™ Only

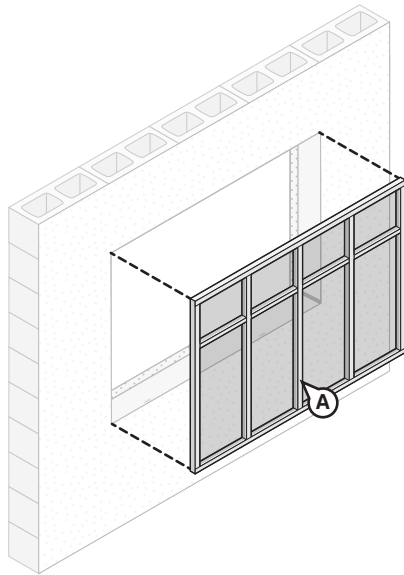

STEP 11

A. Install window per manufacturer's installation instructions.

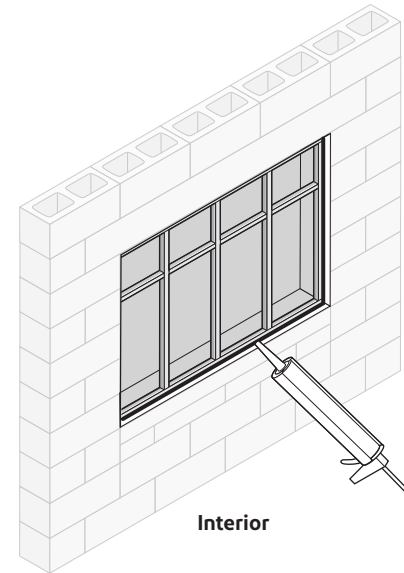

STEP 12

Create Interior Perimeter Seal

Apply a continuous bead of a [chemically-compatible sealant](#) (and backer rod as necessary) around the window opening at the interior. It is also acceptable to use **Great Stuff Pro™ Window & Door Polyurethane Foam Sealant**, or a chemically-compatible foam. When using **Great Stuff Pro™ Window & Door Polyurethane Foam Sealant** in perimeter openings less than 1/2", apply using the plastic extension tip for the **Great Stuff Pro™ Dispensing Gun** during installation.

NOTE: For high performance installations exceeding ASTM E1677 wind loading pressures (10.8 psf, 65 mph equivalent structural load) and ASTM E331 water infiltration resistance of 6.24 psf, a chemically-compatible sealant **must be** installed over the cured foam when using **Great Stuff Pro™ Window and Door Polyurethane Foam Sealant** or a chemically-compatible foam. Sealant should be installed over the foam between the window frame and rough opening around the entire interior perimeter. If **Great Stuff Pro™ Window and Door Polyurethane Foam Sealant** or other chemically-compatible foam extends beyond the window frame, shave the excess cured foam flush with the window frame before applying sealant. Avoid damaging the **DuPont™ Tyvek® Fluid Applied Flashing and Joint Compound+** and/or **DuPont Self-Adhered Flashing Products**.

NOTE: Refer to the Storefront Window CAD details at building.dupont.com for more detailed information.

Installation Methods for DuPont Flashing Products

Wood Bump-Out Frame with Non-Flanged Window

Method 1: Using DuPont™ Tyvek® Fluid Applied Flashing and Joint Compound+ and DuPont™ StraightFlash™

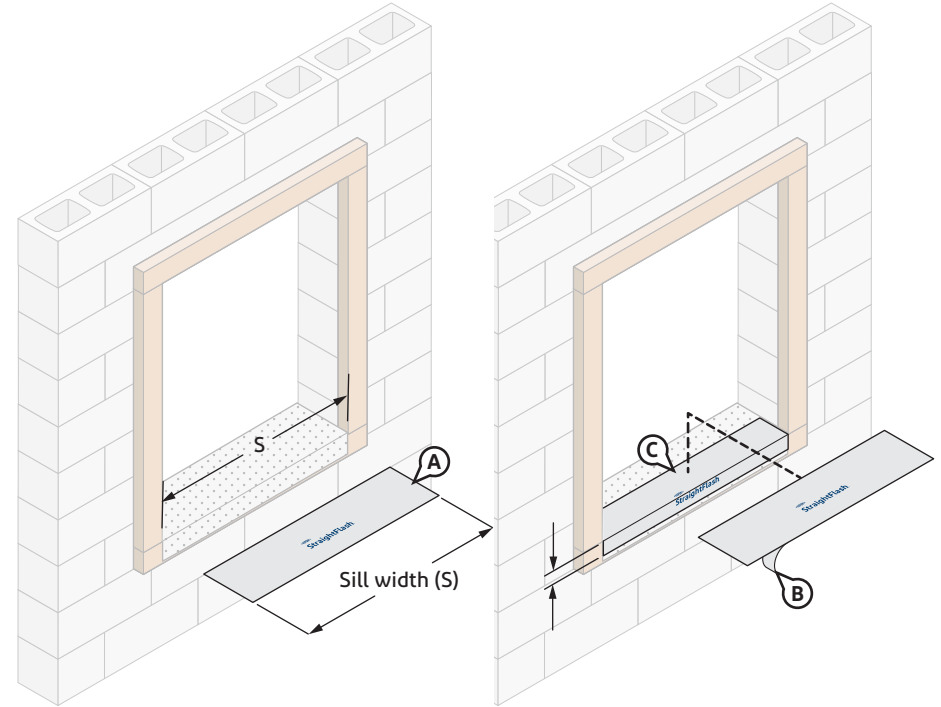
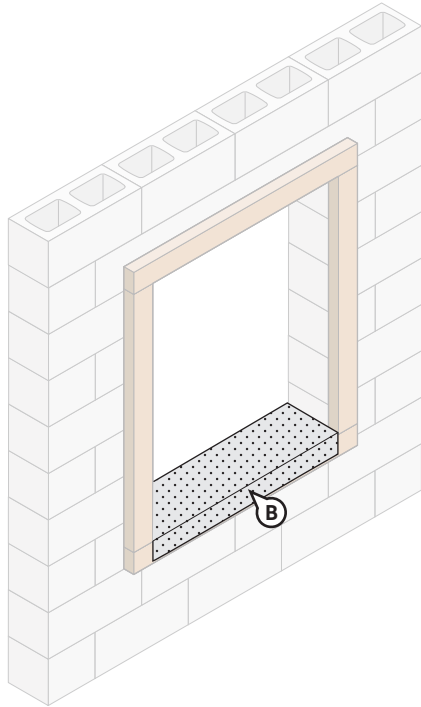

STEP 1

- Clean substrate of any material that could negatively affect adhesion as well as any sharp protrusions.
- When using **StraightFlash™** at the sill of the window, apply a [chemically-compatible adhesive/primer](#) approximately 3" onto the face of the bump-out framing and onto the inside of the sill for masonry and concrete surfaces.

STEP 2

- Cut 9" **StraightFlash™** the width of rough opening sill (S). Ensure a minimum of 1" adhesion **BEYOND** where the back of the window frame will be located, and 2"– 3" adhesion onto the face of the bump-out framing.
- Remove the release paper and position **StraightFlash™** onto the sill and 2" minimum onto the face of the bump-out framing.
- Apply pressure along the entire surface of **StraightFlash™** for a good bond using firm hand pressure or J-roller (or alternate tool without sharp edges such as a plastic carpet tuck tool) to assist with application of uniform pressure.

NOTE: **StraightFlash™** is not required in cases where no fasteners are being installed through the window sill.

Installation Methods for DuPont Flashing Products

Wood Bump-Out Frame with Non-Flanged Window

Method 1: Using DuPont™ Tyvek® Fluid Applied Flashing and Joint Compound+ and DuPont™ StraightFlash™

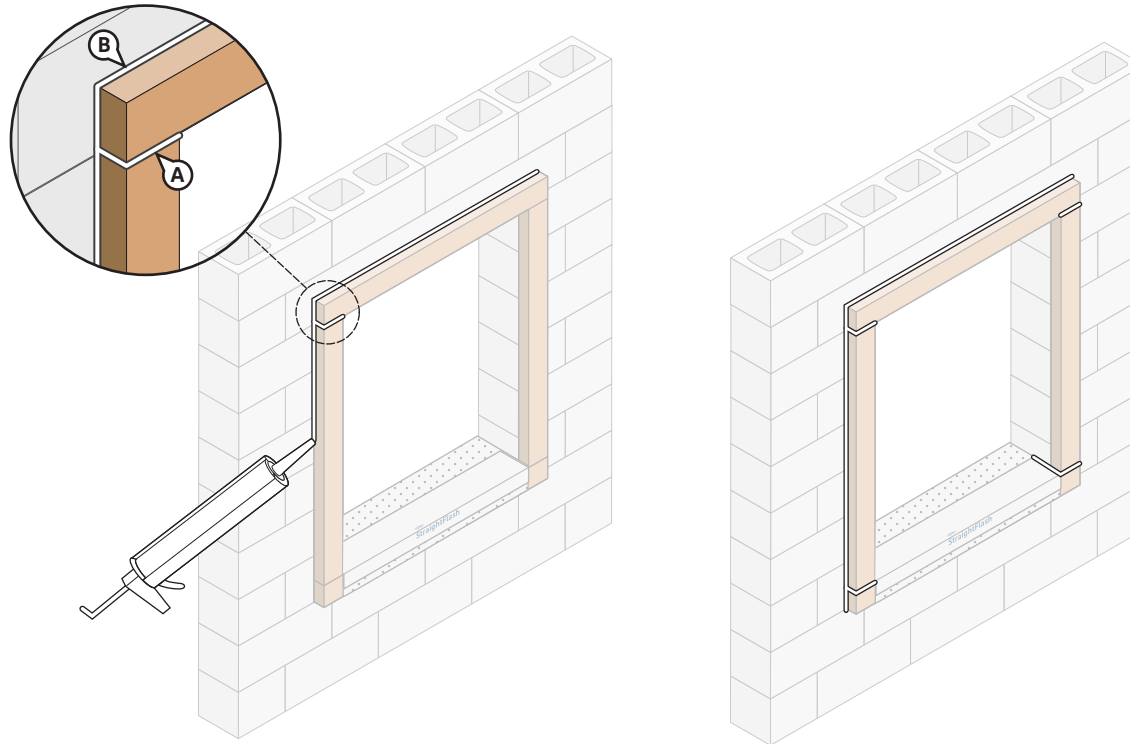

STEP 3

- A. Apply a bead of **Tyvek® Fluid Applied Flashing and Joint Compound+** or a [chemically-compatible sealant](#) to all the seams, and fill any holes or cracks in the bump-out framing and tool flat.
- B. Apply a fillet bead of **Tyvek® Fluid Applied Flashing and Joint Compound+** or a [chemically-compatible sealant](#) around the perimeter of the wood bump-out framing, at the bump-out framing / wall interface. The fillet bead should extend approximately 1/2" onto both surfaces.

- C. Tool sealant to achieve optimal joint design.

NOTE: **Tyvek® Fluid Applied Flashing and Joint Compound+** may be overcoated once a tack-free skin has formed. Skin time is 1–2 hrs at 70°F (20°C), 50% RH.

Installation Methods for DuPont Flashing Products

Wood Bump-Out Frame with Non-Flanged Window

Method 1: Using DuPont™ Tyvek® Fluid Applied Flashing and Joint Compound+ and DuPont™ StraightFlash™

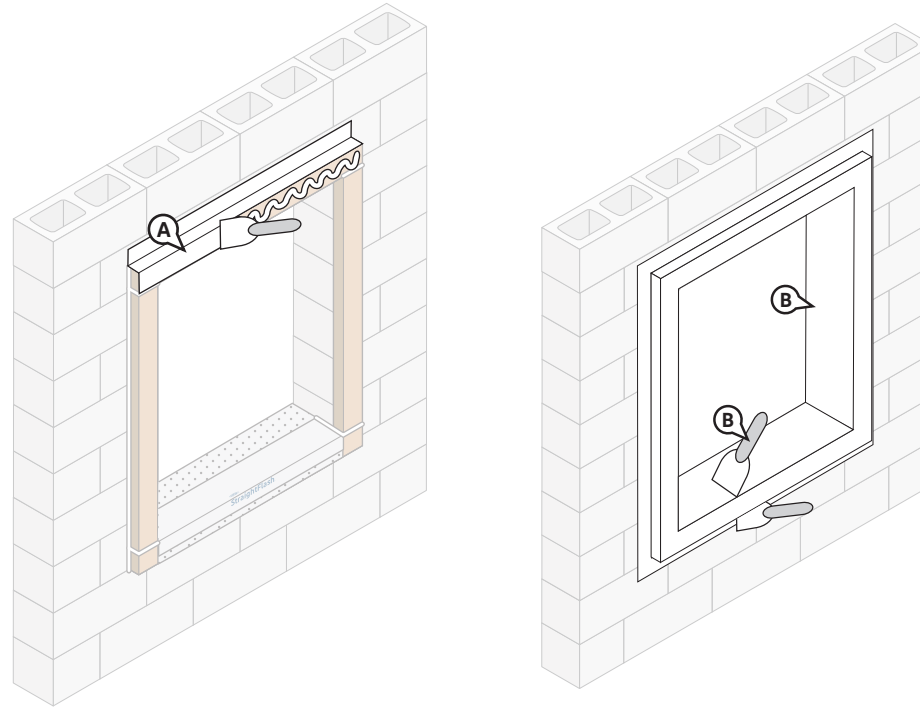

STEP 4

- A. Starting at the window head, apply **Tyvek® Fluid Applied Flashing and Joint Compound+** onto the inside surface of the rough opening, the face and edge of the wood bump-out framing, and a minimum of 2" onto the wall substrate. Use a trowel or brush to smooth out flashing to a thickness of approximately 25 mils.
- B. Apply **Tyvek® Fluid Applied Flashing and Joint Compound+** to the jambs and sill. Be sure all inside corners are filled and integrated with the **StraightFlash™**. Use a trowel or brush to smooth out flashing to a thickness of approximately 25 mils. A corner trowel may be used to smooth outside corners.

NOTE: **Tyvek® Fluid Applied Flashing and Joint Compound+** is **not required** along the entire sill when **StraightFlash™** is installed as previously captured, provided **Tyvek® Fluid Applied Flashing and Joint Compound+** is applied a minimum 4"– 6" along the sill from the jamb corner.

NOTE: If **DuPont™ FlexWrap™** is used along the sill and 6" up the jambs, **Tyvek® Fluid Applied Flashing and Joint Compound+** is not required along the sill to jamb interface but must be applied to head and jamb area.

Installation Methods for DuPont Flashing Products

Wood Bump-Out Frame with Non-Flanged Window

Method 1: Using DuPont™ Tyvek® Fluid Applied Flashing and Joint Compound+ and DuPont™ StraightFlash™

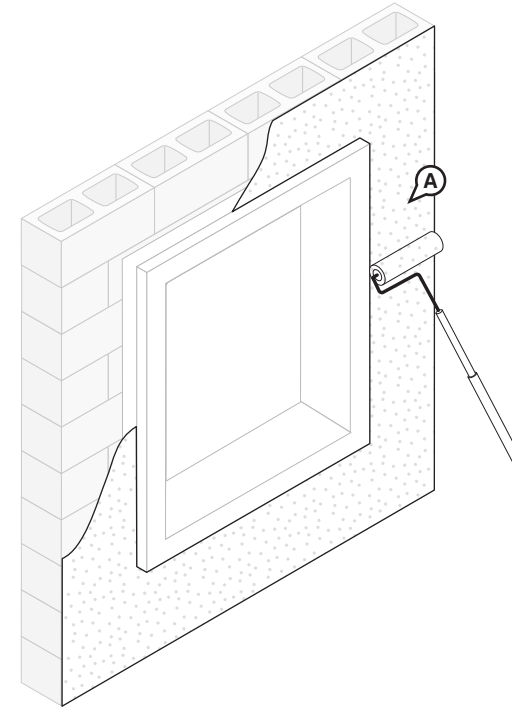
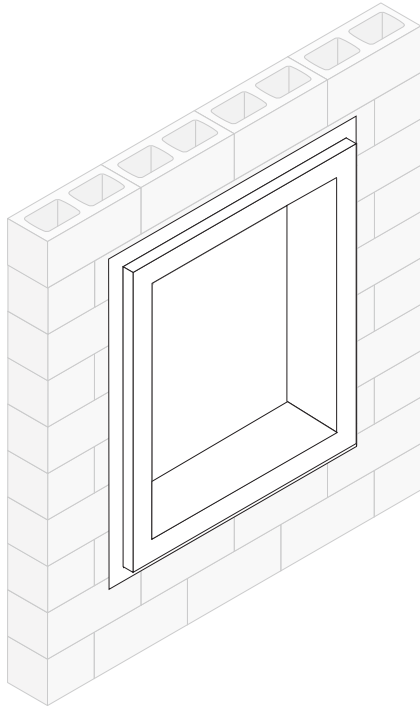

STEP 5

Upon completion, inspect surface, including all corners, to ensure that **Tyvek® Fluid Applied Flashing and Joint Compound+** is continuous and **free of any voids or pinholes**. **DuPont™ Tyvek® Fluid Applied WB+™** may be applied over and integrated with **Tyvek® Fluid Applied Flashing and Joint Compound+** once a tack-free skin has formed. Skin time is 1-2 hrs at 70°F (20°C), 50% RH.

STEP 6

A. Install **Tyvek® Fluid Applied WB+™** up to the edge of the rough opening, overlapping the **Tyvek® Fluid Applied Flashing and Joint Compound+**.

Refer to the [DuPont™ Tyvek® Fluid Applied WB+™ Installation Instructions](#) section of this document. Exterior insulation and/or cladding may be installed once the membrane has cured sufficiently to resist damage during installation. Skin time is 1-2 hours, and 25 mil is workable in 24 hours at 70°F (20°C), 50% RH.

Installation Methods for DuPont Flashing Products

Wood Bump-Out Frame with Non-Flanged Window

Method 1: Using DuPont™ Tyvek® Fluid Applied Flashing and Joint Compound+ and DuPont™ StraightFlash™

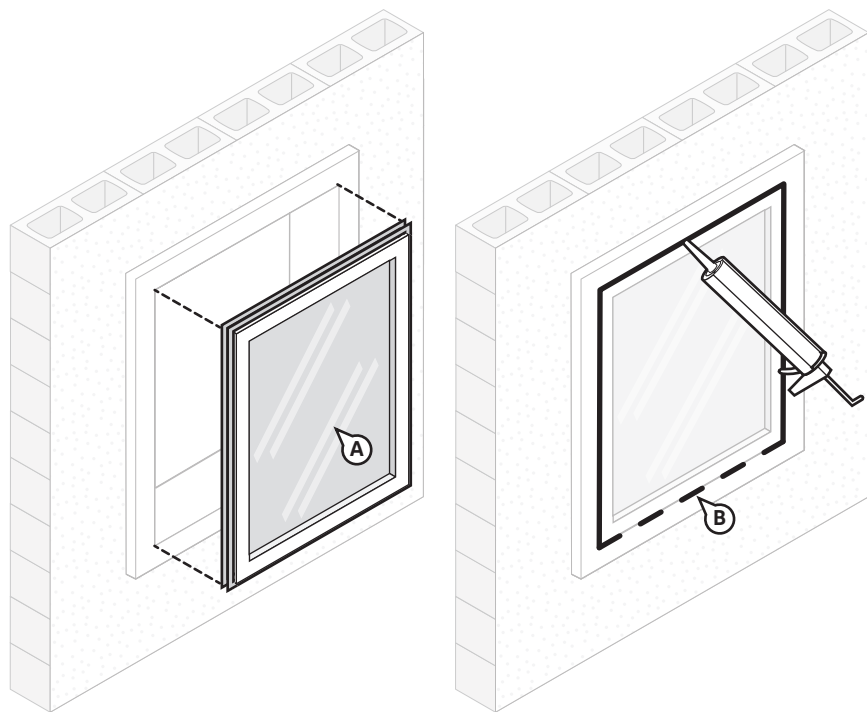

STEP 7

- Install window per manufacturer's installation instructions.
- Apply an exterior perimeter seal using backer rod and [chemically-compatible sealant](#) along the jambs and head of the window opening.

NOTE: To allow for drainage, do not apply continuous sealant bead along sill. Ensure a minimum 2" wide drainage gap in the sealant bead within 4" from each corner of the jamb-sill interface. Continue applying sealant along the sill with additional 2" wide (min.) drainage gaps for every 6"– 12" (on center) of sill width.

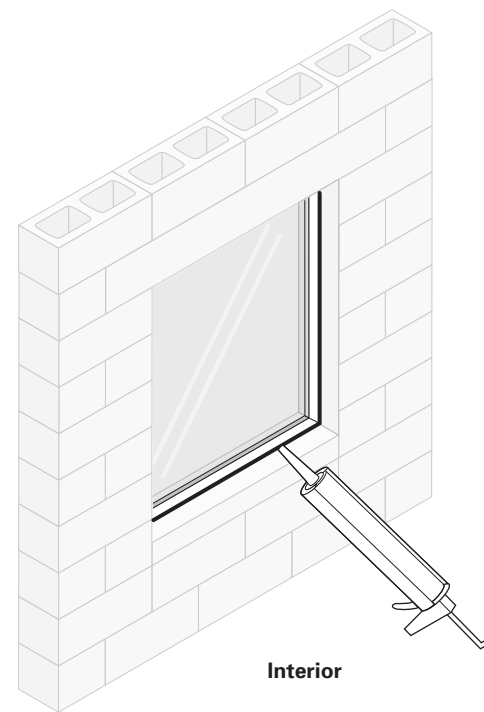

STEP 8

Create Interior Perimeter Seal

Apply a continuous bead of a [chemically-compatible sealant](#) (and backer rod as necessary) around the window opening at the interior. It is also acceptable to use [Great Stuff Pro™ Window & Door Polyurethane Foam Sealant](#), or a chemically-compatible foam. When using [Great Stuff Pro™ Window & Door Polyurethane Foam Sealant](#) in perimeter openings less than 1/2", apply using the plastic extension tip for the [Great Stuff Pro™ Dispensing Gun](#) during installation.

NOTE: For high performance installations exceeding ASTM E1677 wind loading pressures (10.8 psf, 65 mph equivalent structural load) and ASTM E331 water infiltration resistance of 6.24 psf, a chemically-compatible sealant **must be** installed over the cured foam when using [Great Stuff Pro™ Window and Door Polyurethane Foam Sealant](#) or a chemically-compatible foam. Sealant should be installed over the foam between the window frame and rough opening around the entire interior perimeter. If [Great Stuff Pro™ Window and Door Polyurethane Foam Sealant](#) or other chemically-compatible foam extends beyond the window frame, shave the excess cured foam flush with the window frame before applying sealant. Avoid damaging the [Tyvek® Fluid Applied Flashing and Joint Compound+](#) and/or [DuPont Self-Adhered Flashing Products](#).

Installation Methods for DuPont Flashing Products

Wood Bump-Out Frame with Non-Flanged Window

Method 2: Self-Adhered Flashing Using DuPont™ FlexWrap™ and DuPont™ StraightFlash™

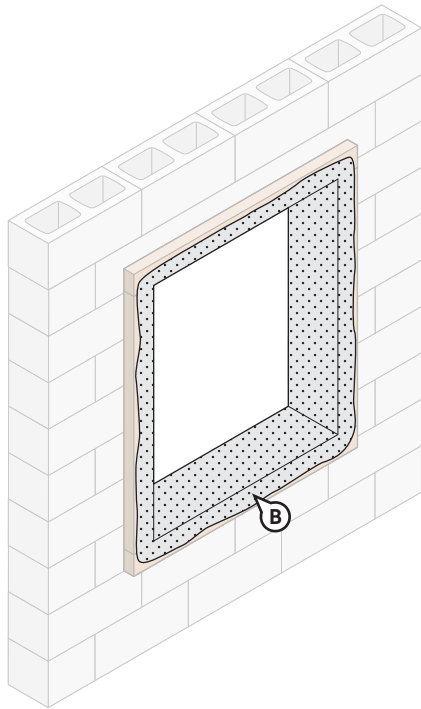

STEP 1

- A. Clean substrate of any material that could negatively affect adhesion, as well as any sharp protrusions.
- B. Apply a [*chemically-compatible adhesive/primer*](#) approximately 3" onto the exterior face of bump-out framing surrounding the rough opening, and onto the inside perimeter of the rough opening for masonry and concrete surfaces.

Installation Methods for DuPont Flashing Products

Wood Bump-Out Frame with Non-Flanged Window

Method 2: Self-Adhered Flashing Using DuPont™ FlexWrap™ and DuPont™ StraightFlash™

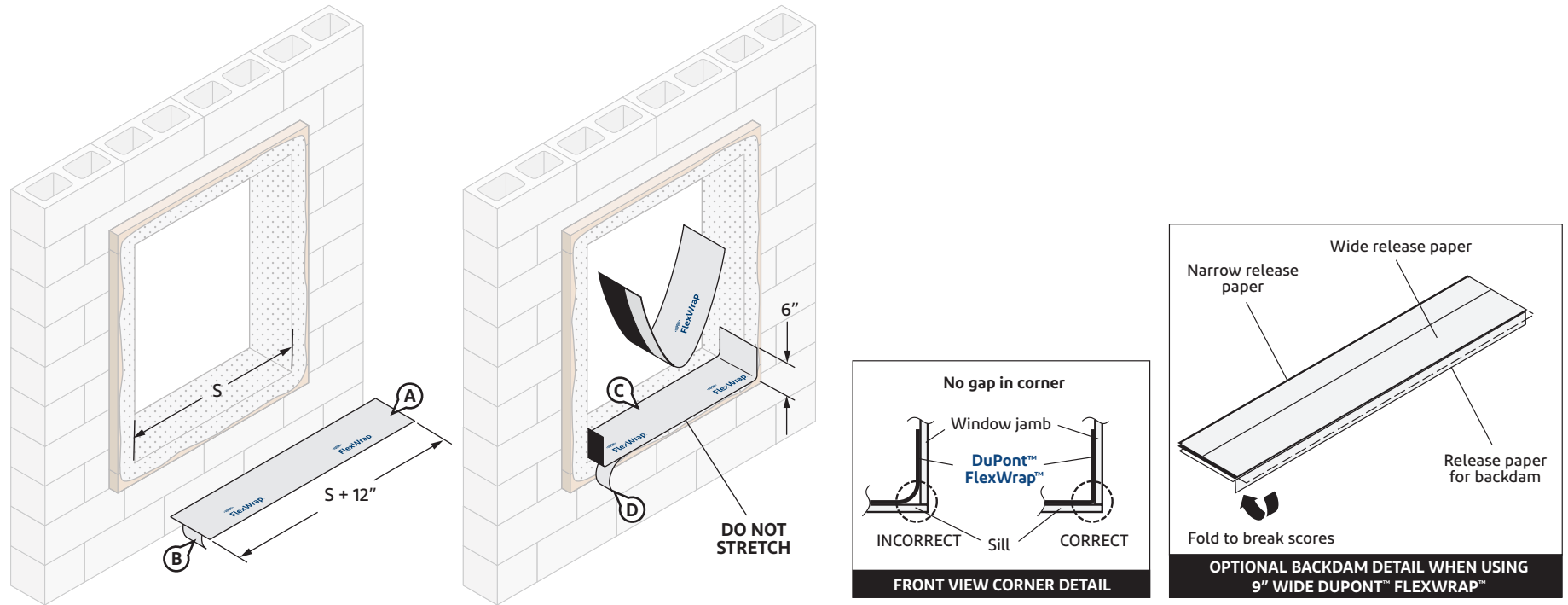

STEP 2

- Cut **FlexWrap™** at least 12" **LONGER** than the width of rough opening sill (S). Use roll widths sufficient to achieve a minimum of 1" adhesion **BEYOND** where the back of the window frame will be located, ensuring 2"– 3" adhesion onto the face of the wood bump-out framing.
- Remove wide piece of release paper.
- Position **FlexWrap™** along the sill by aligning the inside of the narrow release paper with the face of the bump-out framing to ensure 2"– 3" of the **FlexWrap™** will be adhered to the face of the bump-out framing with a minimum of 6" up each jamb. Adhere into rough opening.

Optional Back Dam: Fold 9" **FlexWrap™** to break perforation. Remove center piece of release paper. Cover horizontal sill to accommodate back dam as appropriate, and adhere into rough opening along sill and up jambs (min 6" on each side). Leave 1" release paper on **FlexWrap™** inside rough opening to finish back dam after window installation.

- Remove remaining release paper.

NOTE: Use of the optional back dam **must not** interfere with the installation of a continuous interior perimeter seal.

NOTE: DuPont™ Tyvek® Commercial Certified Installers may install a 3-piece head (and sill) detail for window openings less than 6 ft wide. Installers who **are not** DuPont™ Tyvek® Commercial Certified Installers should refer to the [Special Considerations](#) section for more information regarding the 3-piece head/sill detail. Contact your local DuPont Building Envelope Specialist for more information about the Certified Installer program.

Installation Methods for DuPont Flashing Products

Wood Bump-Out Frame with Non-Flanged Window

Method 2: Self-Adhered Flashing Using DuPont™ FlexWrap™ and DuPont™ StraightFlash™

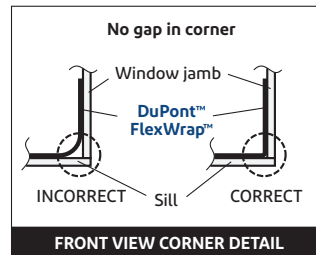
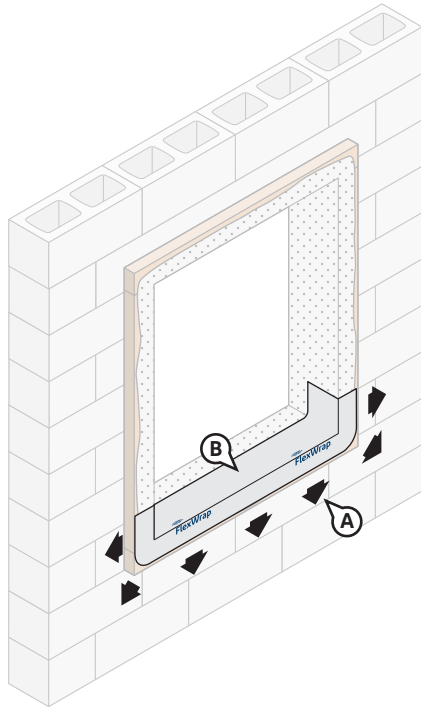

STEP 3

- Fan out the **FlexWrap™** at corners and adhere onto face of bump-out framing. Continue adhering onto face of bump-out framing along sill.
- Firmly press sill flashing to ensure full adhesion on all surfaces. Eliminate wrinkles and bubbles by smoothing surface and repositioning as necessary.

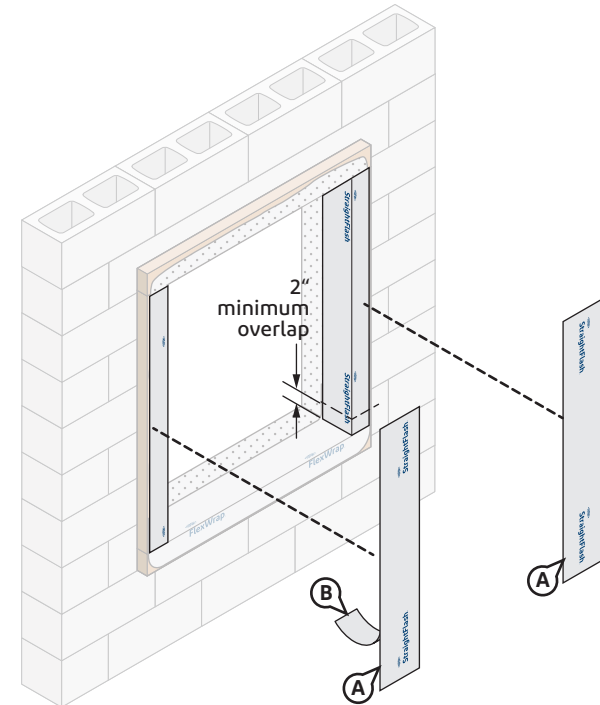

STEP 4

- Cut two pieces of 9" **StraightFlash™** to the length of the jamb. Jamb flashing should overlap the sill flashing by at least 2" and be overlapped by future head flashing by at least 2".
- Remove release paper and position **StraightFlash™** so that 2" will extend onto the bump-out framing. Wrap jamb flashing into the rough opening at each jamb and onto the face of the bump-out framing. Apply pressure along entire surface of flashing for a good bond using firm hand pressure, J-roller, or alternate tool without sharp edges (such as a plastic carpet tuck tool) to assist with application of uniform pressure during installation of **DuPont Self-Adhered Flashing Products**. Eliminate wrinkles and bubbles by smoothing surface.

Installation Methods for DuPont Flashing Products

Wood Bump-Out Frame with Non-Flanged Window

Method 2: Self-Adhered Flashing Using DuPont™ FlexWrap™ and DuPont™ StraightFlash™

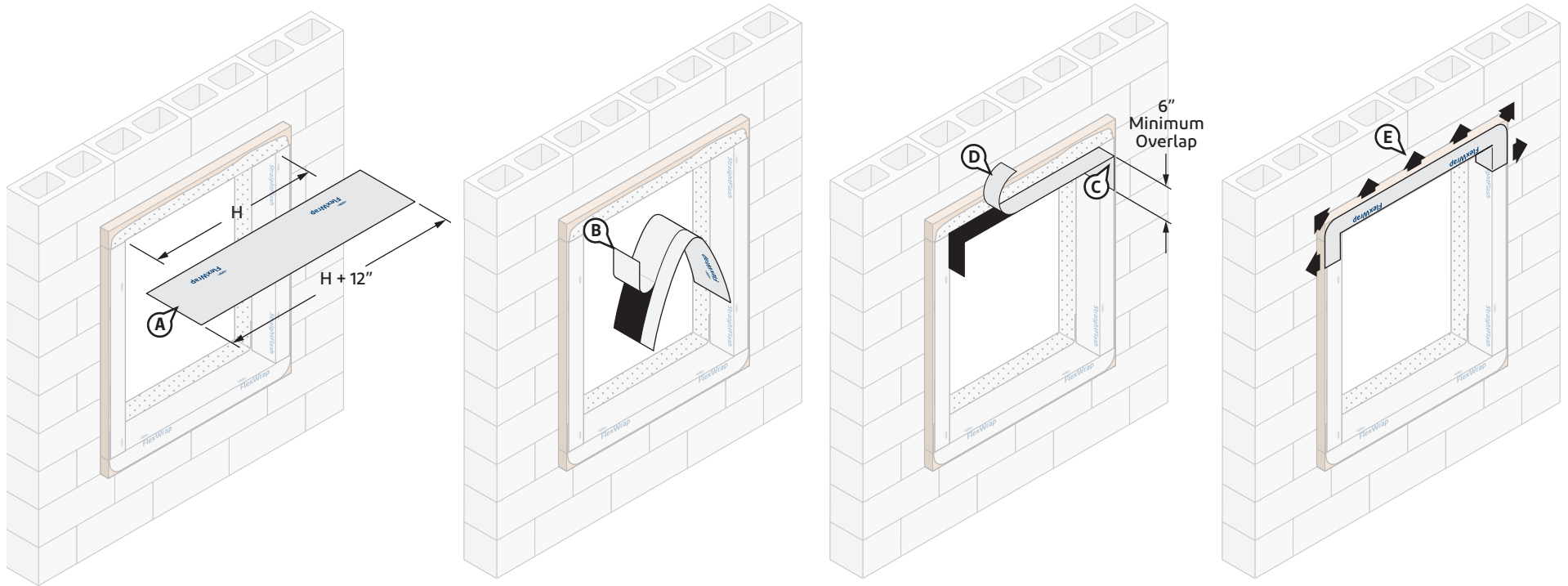

STEP 5

- A. Cut **FlexWrap™** at least 12" **LONGER** than the width of rough opening head (H). Use roll widths sufficient to achieve a minimum of 1" adhesion **BEYOND** where the window frame will be located, ensuring 2"– 3" adhesion onto the face of the wood bump-out framing.
- B. Fold the **FlexWrap™** in half lengthwise to create a slight crease at the center. Remove the wide piece of release paper on one side of the fold. Align the inside edge of the narrow release paper with the face of the bump-out to ensure 2"– 3" of the **FlexWrap™** will be adhered to the face of the bump-out framing.
- C. Starting at the crease, adhere the the exposed butyl adhesive to the center of the head and a minimum of 6" down the jamb. Remove the remaining release paper and continue process of adhering **FlexWrap™** along the head of the rough opening and 6" down the opposite jamb.
- D. Remove remaining release paper.
- E. Fan out the **FlexWrap™** at corners and adhere onto face of bump-out framing.

NOTE: DuPont™ Tyvek® Commercial Certified Installers may install a 3-piece head (and sill) detail for window openings less than 6 ft wide. Installers who **are not** DuPont™ Tyvek® Commercial Certified Installers should refer to the [Special Considerations](#) section for more information regarding the 3-piece head/sill detail. Contact your local DuPont Building Envelope Specialist for more information about the Certified Installer program.

Installation Methods for DuPont Flashing Products

Wood Bump-Out Frame with Non-Flanged Window

Method 2: Self-Adhered Flashing Using DuPont™ FlexWrap™ and DuPont™ StraightFlash™

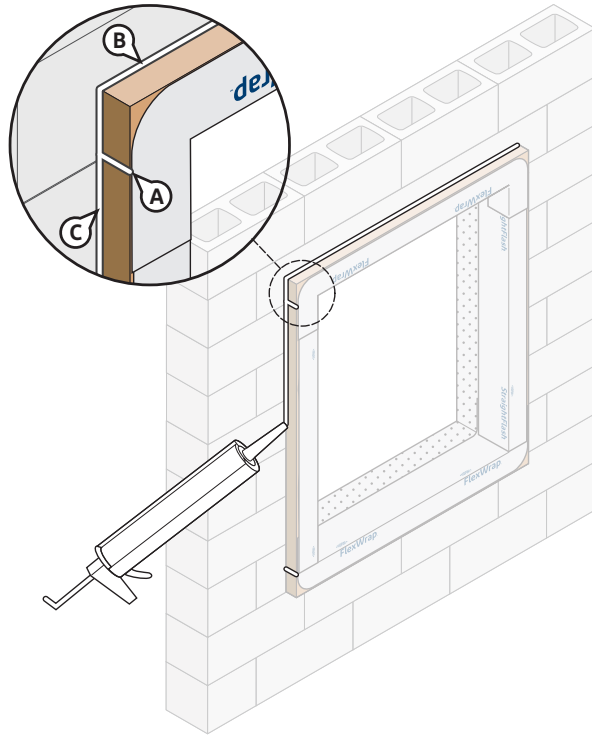

STEP 6

- Apply a bead of **DuPont™ Tyvek® Fluid Applied Flashing and Joint Compound+** or a [chemically-compatible sealant](#) to the seams in the bump-out framing. Fill any remaining holes or cracks in bump-out framing using the joint compound or sealant, and tool flat.
- Apply a fillet bead of **Tyvek® Fluid Applied Flashing and Joint Compound+** or a [chemically-compatible sealant](#) to the perimeter of the bump-out framing/wall interface. Fillet bead should extend approximately 1/2" onto both surfaces.
- Tool **Tyvek® Fluid Applied Flashing and Joint Compound+** or sealant to achieve optimal joint design.

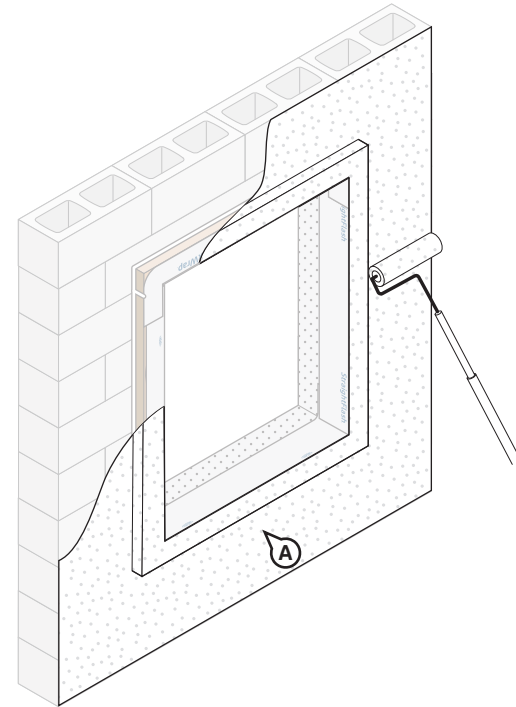

STEP 7

- Install **DuPont™ Tyvek® Fluid Applied WB+™** onto wall and bump-out framing at 25 mils thick. Coat bump-out framing up to the edge of the rough opening, overlapping the **DuPont Self-Adhered Flashing Product**. Coating the **DuPont Self-Adhered Flashing Product** into the sill, is also acceptable. Upon completion, inspect all surfaces to ensure that they are covered and **free of any voids or pinholes**.

NOTE: When spraying, the outer edge of **DuPont Self-Adhered Flashing Product** may need to be pretreated with a **DuPont™ Tyvek® Fluid Applied Product** tapered to wall substrate to help ensure installation is free of pinholes and voids.

Refer to the [DuPont™ Tyvek® Fluid Applied WB+™ Installation Instructions](#) section of this document. Exterior insulation and/or cladding may be installed once the membrane has cured sufficiently to resist damage during installation. Skin time is 1-2 hours, and 25 mil is workable in 24 hours at 70°F (20°C), 50% RH.

Installation Methods for DuPont Flashing Products

Wood Bump-Out Frame with Non-Flanged Window

Method 2: Self-Adhered Flashing Using DuPont™ FlexWrap™ and DuPont™ StraightFlash™

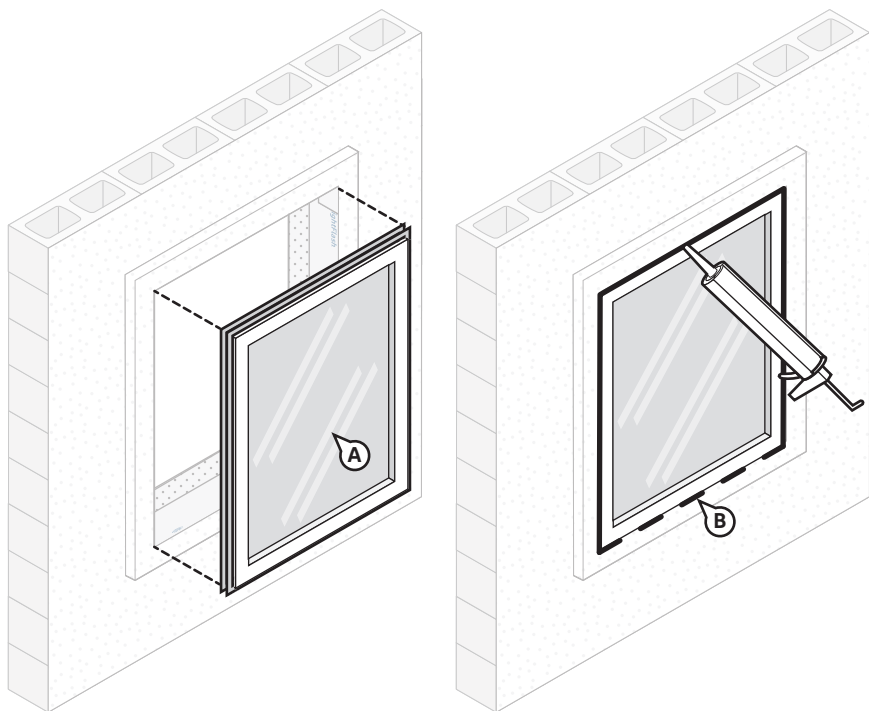

STEP 8

- Install window per manufacturer's installation instructions.
- Apply an exterior perimeter seal using backer rod and [chemically-compatible sealant](#) along the jambs and head of the window opening.

NOTE: To allow for drainage, do not apply continuous sealant bead along sill. Ensure a minimum 2" wide drainage gap in the sealant bead within 4" from each corner of the jamb-sill interface. Continue applying sealant along the sill with additional 2" wide (min.) drainage gaps for every 6"– 12" (on center) of sill width.

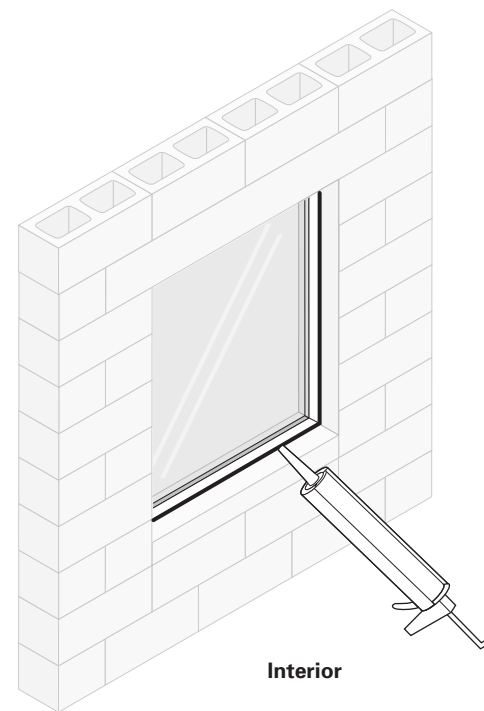

STEP 9

Create Interior Perimeter Seal

Apply a continuous bead of a [chemically-compatible sealant](#) (and backer rod as necessary) around the window opening at the interior. It is also acceptable to use **Great Stuff Pro™ Window & Door Polyurethane Foam Sealant**, or a chemically-compatible foam. When using **Great Stuff Pro™ Window & Door Polyurethane Foam Sealant** in perimeter openings less than 1/2", apply using the plastic extension tip for the **Great Stuff Pro™ Dispensing Gun** during installation.

NOTE: For high performance installations exceeding ASTM E1677 wind loading pressures (10.8 psf, 65 mph equivalent structural load) and ASTM E331 water infiltration resistance of 6.24 psf, a chemically-compatible sealant **must be** installed over the cured foam when using **Great Stuff Pro™ Window and Door Polyurethane Foam Sealant** or a chemically-compatible foam. Sealant should be installed over the foam between the window frame and rough opening around the entire interior perimeter. If **Great Stuff Pro™ Window and Door Polyurethane Foam Sealant** or other chemically-compatible foam extends beyond the window frame, shave the excess cured foam flush with the window frame before applying sealant. Avoid damaging the **DuPont™ Tyvek® Fluid Applied Flashing and Joint Compound+** and/or **DuPont Self-Adhered Flashing Products**.

Installation Methods for DuPont Flashing Products

Wood Bump-Out Frame with Non-Flanged Window

Method 3: Alternate Self-Adhered Flashing Option Using DuPont™ StraightFlash™ Only

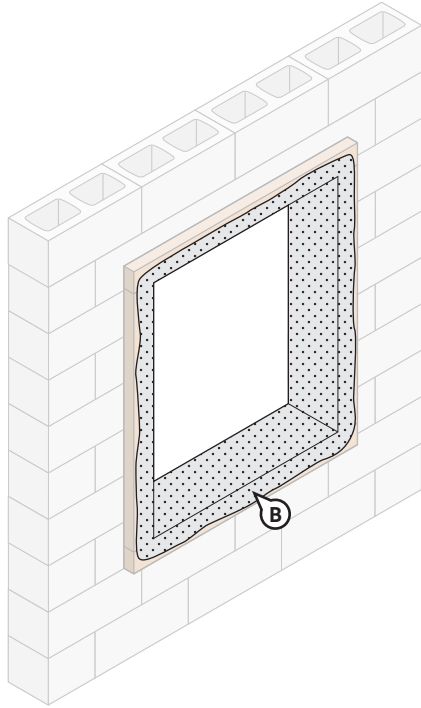

STEP 1

- A. Clean substrate of any material that could negatively affect adhesion, as well as any sharp protrusions.
- B. Apply a [chemically-compatible adhesive/primer](#) approximately 3" onto the exterior face of the wood bump-out framing surrounding the rough opening, and onto the inside perimeter of the rough opening for masonry and concrete surfaces.

Installation Methods for DuPont Flashing Products Wood Bump-Out Frame with Non-Flanged Window

Method 3: Alternate Self-Adhered Flashing Option Using DuPont™ StraightFlash™ Only

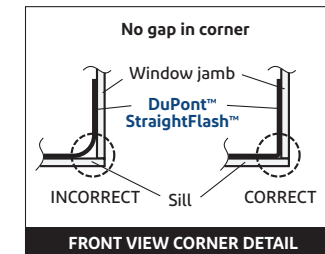
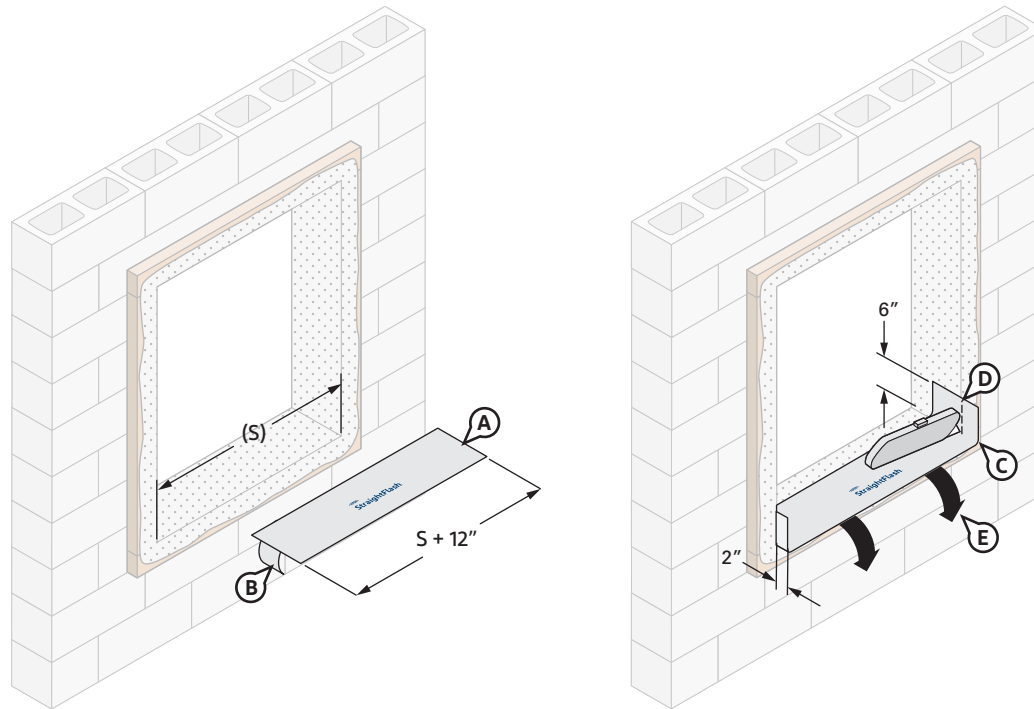

STEP 2

- A. Prepare the sill flashing by cutting a piece of **StraightFlash™** that is at least 12" **LONGER** than the sill width.
- B. Install the **StraightFlash™** by removing the widest strip of release paper, and aligning the flashing so it extends 1" **BEYOND** where the back of the window frame will be located, 2"– 3" onto the face of wall, and 6" up the jambs.
- C. Secure flashing tightly into the corners by first working it in along the sill before adhering it up the jambs. (See front view corner detail above).
- D. Cut the jamb portion of the sill flashing even with the face of the bump-out-framing.
- E. With release paper still attached, fold flashing down onto the face of the bump-out framing.

Installation Methods for DuPont Flashing Products

Wood Bump-Out Frame with Non-Flanged Window

Method 3: Alternate Self-Adhered Flashing Option Using DuPont™ StraightFlash™ Only

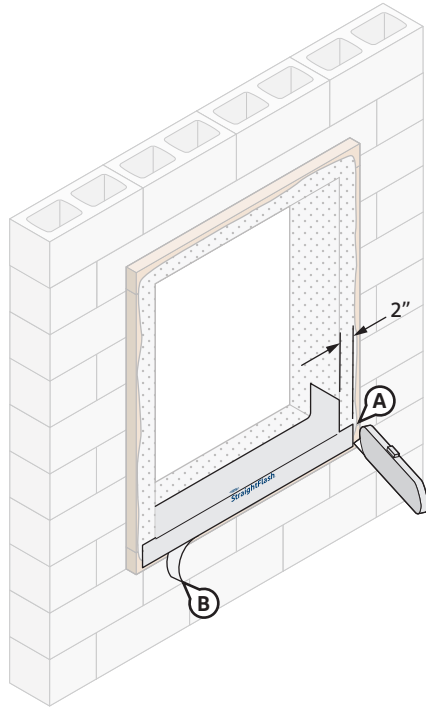

STEP 3

- Flaps created from vertical cuts in **StraightFlash™** should be trimmed so they do not extend more than 2" beyond jamb rough opening onto the face of the bump-out framing.
- Remove remaining release paper and firmly press flashing onto the face of the bump-out framing.

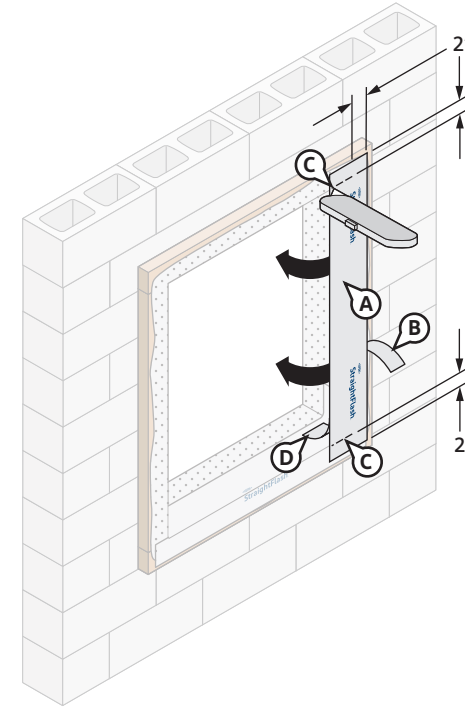

STEP 4

- Prepare the jamb flashing by cutting two pieces of **StraightFlash™** that are 4" longer than the jamb length.
- Remove the 2" wide portion of the release paper. Place the flashing onto the face of the bump-out so that it extends a minimum of 2" past the jamb, head, and sill of the rough opening.
- Cut the **StraightFlash™** along the head and the sill of the rough opening. Flaps created from horizontal cuts in **StraightFlash™** should be trimmed so they do not extend more than 2"-3" along the face of bump-out framing beyond sill-to-jamb and head-to-jamb interfaces.
- Remove the remaining release paper. Fold the **StraightFlash™** into the rough opening and adhere it to the jamb.

Installation Methods for DuPont Flashing Products

Wood Bump-Out Frame with Non-Flanged Window

Method 3: Alternate Self-Adhered Flashing Option Using DuPont™ StraightFlash™ Only

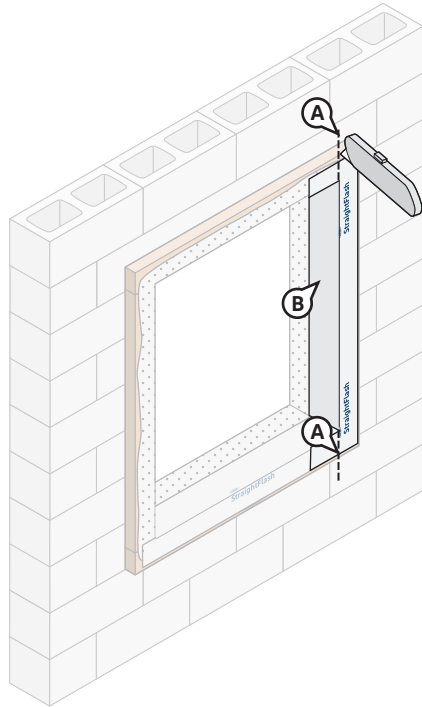

STEP 5

- A. Cut vertically along the remaining release paper and remove the excess flashing from the head and the sill.
- B. Firmly press flashing onto the jambs, face of bump-out framing and the sill flashing overlaps.
- C. Install second piece of **StraightFlash™** to opposite jamb.

Installation Methods for DuPont Flashing Products

Wood Bump-Out Frame with Non-Flanged Window

Method 3: Alternate Self-Adhered Flashing Option Using DuPont™ StraightFlash™ Only

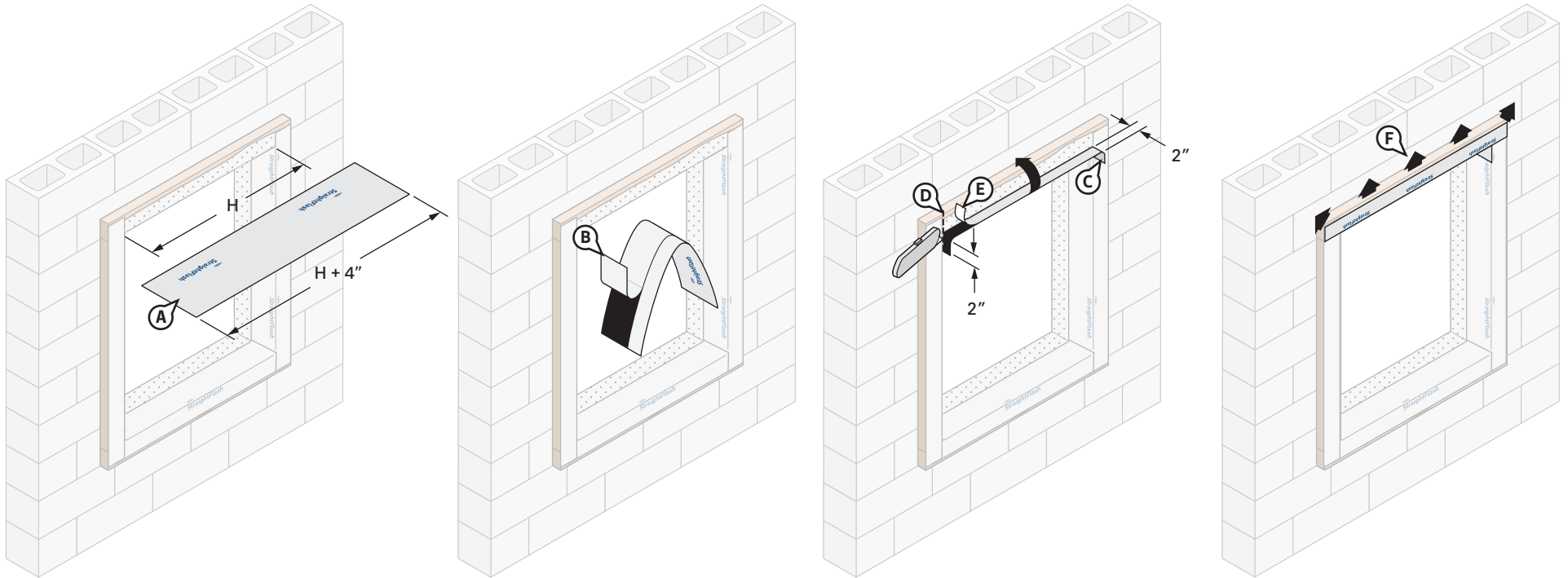

STEP 6

- Prepare the head flashing by cutting a piece of **StraightFlash™** that is at least 4" longer than the length of the rough opening head (H).
- Install the **StraightFlash™** by removing the widest strip of release paper, and aligning the flashing so that a minimum of 2" will extend onto the face of the bump-out framing and will overlap the jamb flashing by at least 2".
- Secure flashing tightly into the corners by first working it in along the head before adhering it down the jambs.
- Cut the jamb portion of the head flashing even with the face of the bump-out frame.
- Remove the remaining release paper.
- Fold **StraightFlash™** up and firmly press flashing onto the face of the bump-out framing and jamb flashing overlaps. Apply pressure along entire surface of flashing for a good bond using firm hand pressure, J-roller, or alternate tool without sharp edges (such as a plastic carpet tuck tool) to assist with application of uniform pressure.

Installation Methods for DuPont Flashing Products

Wood Bump-Out Frame with Non-Flanged Window

Method 3: Alternate Self-Adhered Flashing Option Using DuPont™ StraightFlash™ Only

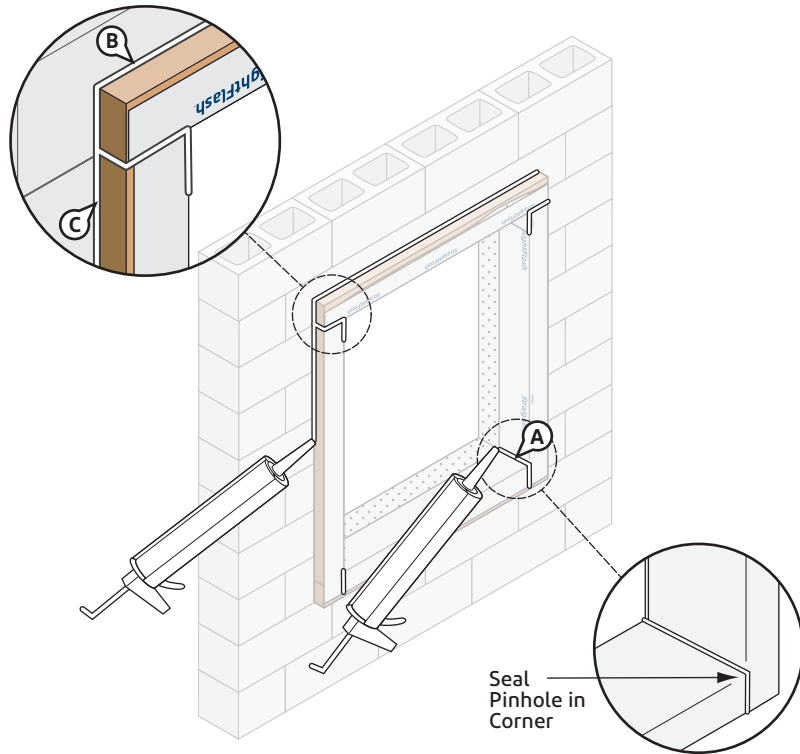

STEP 7

- A. Seal all four inside corners with **DuPont™ Tyvek® Fluid Applied Flashing and Joint Compound+** or a *chemically-compatible sealant*. Extend sealant approximately 1/2" onto the face of the bump-out framing flashing.

NOTE: Be sure that the pinholes in the flashing corners are fully covered with with **Tyvek® Fluid Applied Flashing and Joint Compound+** or a *chemically-compatible sealant*.

- B. Apply a fillet bead of **Tyvek® Fluid Applied Flashing and Joint Compound+** or a *chemically-compatible sealant* around the perimeter of the wood bump-out frame wall interface. The fillet bead should extend approximately 1/2" onto both surfaces, and tool flat.

- C. Tool sealant to achieve optimal joint design.

NOTE: **DuPont™ Tyvek® Fluid Applied Products** may be overcoated once a tack-free skin has formed. Skin time is 1-2 hrs at 70°F (20°C), 50% RH.

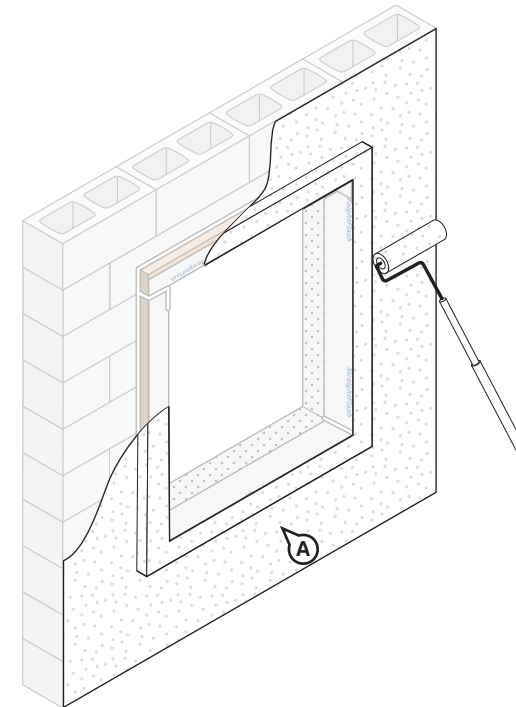

STEP 8

- A. Install **DuPont™ Tyvek® Fluid Applied WB+™** onto wall at 25 mils thick. Coat wood buck, if applicable, up to the edge of the rough opening, overlapping the **DuPont Self-Adhered Flashing Product**. Coating the **DuPont Self-Adhered Flashing Product** into the sill is also acceptable. Upon completion, inspect all surfaces to ensure that they are covered and **free of any voids or pinholes**.

NOTE: When spraying, the outer edge of **DuPont Self-Adhered Flashing Product** should be treated with **Tyvek® Fluid Applied Flashing and Joint Compound+**, and tapered to wall substrate to help ensure installation is free of pinholes and voids.

Refer to the *DuPont™ Tyvek® Fluid Applied WB+™ Installation Instructions* section of this document. Skin time is 1-2 hours, and 25 mils is workable in 24 hours at 70°F (20°C), 50% RH.

Installation Methods for DuPont Flashing Products

Wood Bump-Out Frame with Non-Flanged Window

Method 3: Alternate Self-Adhered Flashing Option Using DuPont™ StraightFlash™ Only

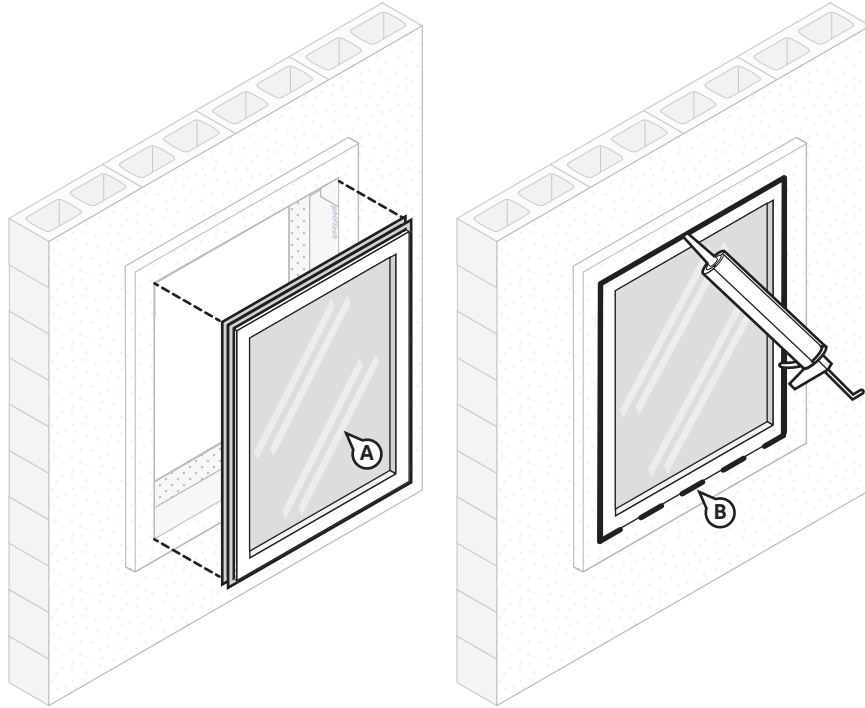

STEP 9

- Install window per manufacturer's installation instructions.
- Apply an exterior perimeter seal using backer rod and [chemically-compatible sealant](#) along the jambs and head of the window opening.

NOTE: To allow for drainage, do not apply continuous sealant bead along sill. Ensure a minimum 2" wide drainage gap in the sealant bead within 4" from each corner of the jamb-sill interface. Continue applying sealant along the sill with additional 2" wide (min.) drainage gaps for every 6"–12" (on center) of sill width.

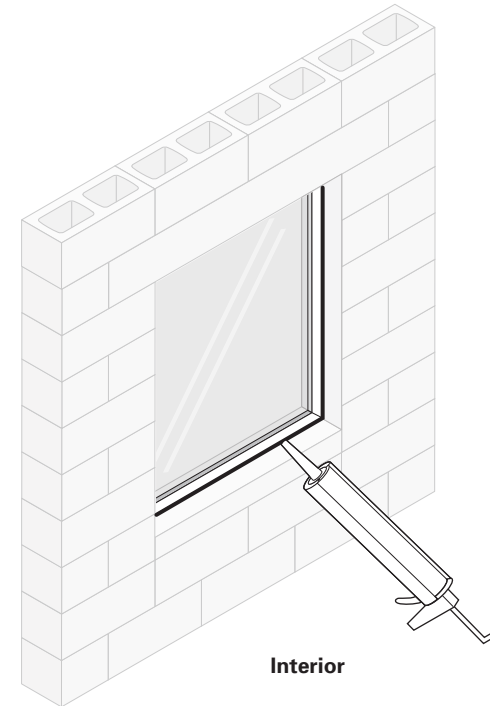

STEP 10

Create Interior Perimeter Seal

Apply a continuous bead of a [chemically-compatible sealant](#) (and backer rod as necessary) around the window opening at the interior. It is also acceptable to use [Great Stuff Pro™ Window & Door Polyurethane Foam Sealant](#), or a chemically-compatible foam. When using [Great Stuff Pro™ Window & Door Polyurethane Foam Sealant](#) in perimeter openings less than 1/2", apply using the plastic extension tip for the [Great Stuff Pro™ Dispensing Gun](#) during installation.

NOTE: For high performance installations exceeding ASTM E1677 wind loading pressures (10.8 psf, 65 mph equivalent structural load) and ASTM E331 water infiltration resistance of 6.24 psf, a chemically-compatible sealant **must be** installed over the cured foam when using [Great Stuff Pro™ Window and Door Polyurethane Foam Sealant](#) or a chemically-compatible foam. Sealant should be installed over the foam between the window frame and rough opening around the entire interior perimeter. If [Great Stuff Pro™ Window and Door Polyurethane Foam Sealant](#) or other chemically-compatible foam extends beyond the window frame, shave the excess cured foam flush with the window frame before applying sealant. Avoid damaging the [DuPont™ Tyvek® Fluid Applied Flashing and Joint Compound+](#) and/or [DuPont Self-Adhered Flashing Products](#).

Installation Methods for DuPont Flashing Products Wood Bump-Out Frame with Integral Flanged Window

Using DuPont™ Tyvek® Fluid Applied Flashing and Joint Compound+

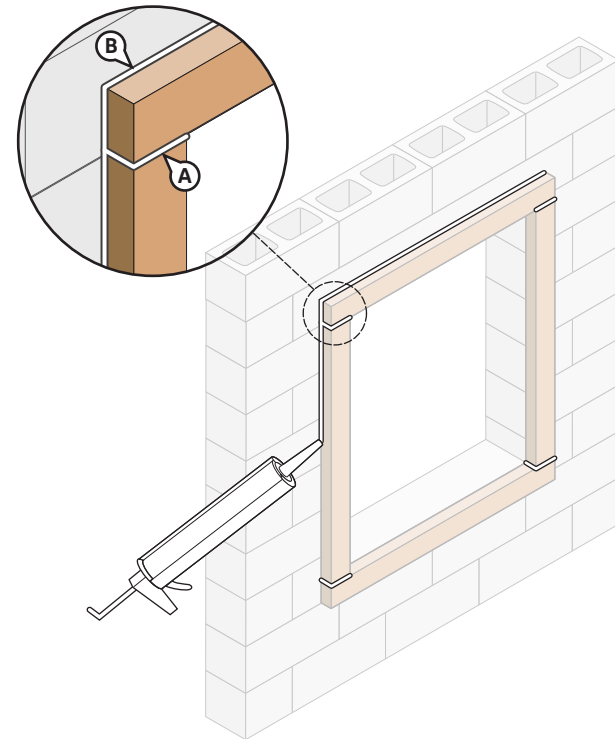
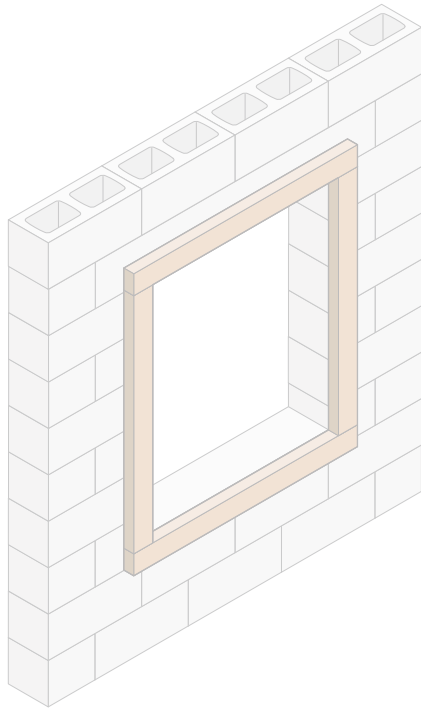

STEP 1

A. Clean substrate of any material that could negatively affect adhesion as well as any sharp protrusions.

STEP 2

- A. Apply a bead of **Tyvek® Fluid Applied Flashing and Joint Compound+** or a [*chemically-compatible sealant*](#) to all the seams, and fill any holes or cracks in the bump-out framing and tool flat.
- B. Apply a fillet bead of **Tyvek® Fluid Applied Flashing and Joint Compound+** or a [*chemically-compatible sealant*](#) around the perimeter of the wood bump-out framing at the wall interface. The fillet bead should extend approximately 1/2" onto both surfaces.
- C. Tool sealant to achieve optimal joint design.

NOTE: **Tyvek® Fluid Applied Flashing and Joint Compound+** may be overcoated once a tack-free skin has formed. Skin time is 1-2 hrs at 70°F (20°C), 50% RH.

Installation Methods for DuPont Flashing Products

Wood Bump-Out Frame with Integral Flanged Window

Using DuPont™ Tyvek® Fluid Applied Flashing and Joint Compound+

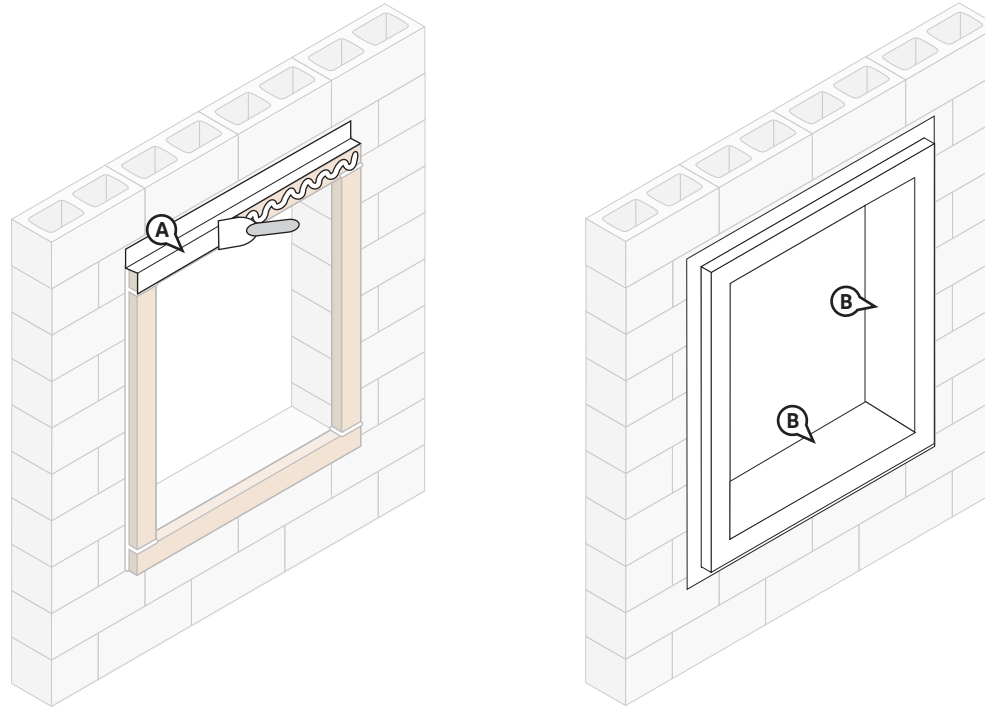

STEP 3

A. Starting at the window head, apply **Tyvek® Fluid Applied Flashing and Joint Compound+** onto the inside surface of the rough opening, the face and edge of the wood bump-out framing, and a minimum of 2" onto the wall substrate. Use a trowel or brush to smooth out flashing to a thickness of approximately 25 mils.

B. Apply **Tyvek® Fluid Applied Flashing and Joint Compound+** to the jambs and sill. Use a trowel or brush to smooth out flashing to a thickness of approximately 25 mils.

NOTE: A **DuPont Self-Adhered Flashing Product** is **not required** along the sill of an integral flanged window.

Installation Methods for DuPont Flashing Products Wood Bump-Out Frame with Integral Flanged Window

Using DuPont™ Tyvek® Fluid Applied Flashing and Joint Compound+

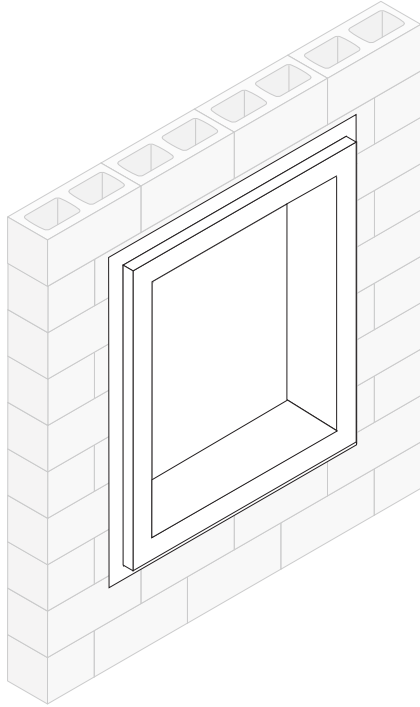

STEP 4

Upon completion, inspect surface, including all corners, to ensure that **Tyvek® Fluid Applied Flashing and Joint Compound+** is continuous and **free of any voids or pinholes**. **DuPont™ Tyvek® Fluid Applied WB+™** may be applied over and integrated with **Tyvek® Fluid Applied Flashing and Joint Compound+** once a tack-free skin has formed. Skin time is 1-2 hrs at 70°F (20°C), 50% RH.

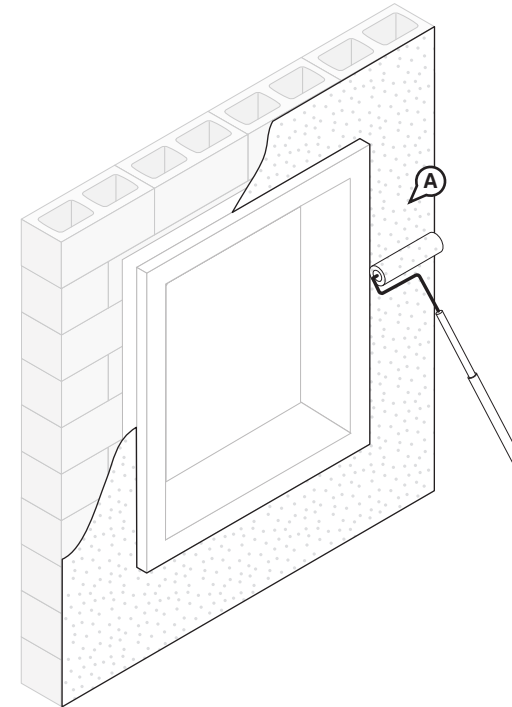

STEP 5

A. Install **Tyvek® Fluid Applied WB+™** up to the edge of the wood bump-out framing, overlapping the **Tyvek® Fluid Applied Flashing and Joint Compound+**.

Refer to the [DuPont™ Tyvek® Fluid Applied WB+™ Installation Instructions](#) section of this document. Exterior insulation and/or cladding may be installed once the membrane has cured sufficiently to resist damage during installation. Skin time is 1-2 hours, and 25 mil is workable in 24 hours at 70°F (20°C), 50% RH.

Installation Methods for DuPont Flashing Products Wood Bump-Out Frame with Integral Flanged Window

Using DuPont™ Tyvek® Fluid Applied Flashing and Joint Compound+

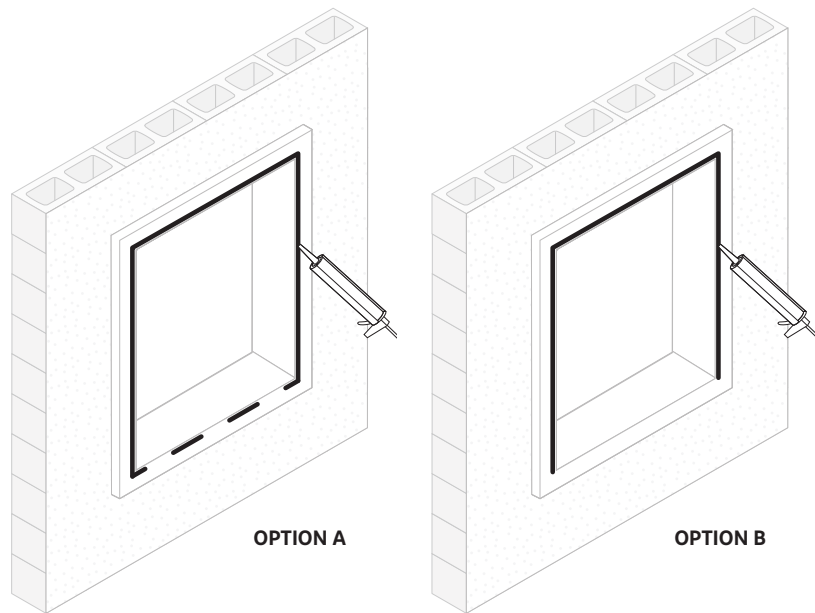

OPTION A

OPTION B

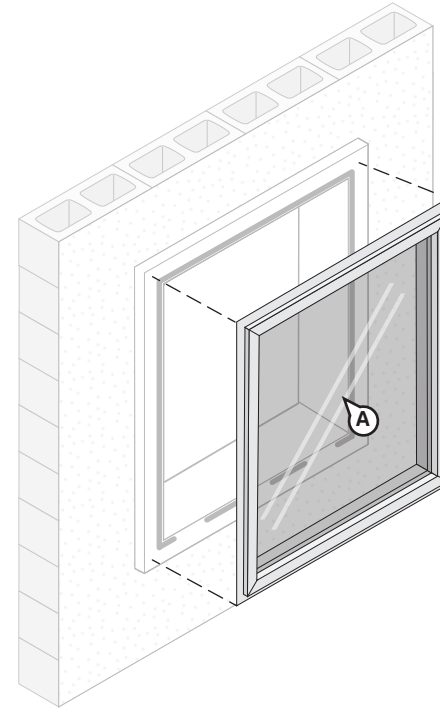

STEP 6

OPTION A: Apply a continuous bead of a [chemically-compatible sealant](#) along the jambs and head of the bump-out frame or the back side of the window mounting flange. **o allow for drainage, do not apply continuous sealant bead along sill.** Ensure a minimum 2" wide drainage gap in the sealant bead within 4" from each corner of the jamb-sill interface. Continue applying sealant along the sill with additional 2" wide (min.) drainage gaps for every 6"– 12" (on center) of sill width.

OPTION B: Apply continuous bead of a [chemically-compatible sealant](#) at the window head and jambs to wall or back side of window mounting flange. **To allow for drainage, do not apply sealant bead along sill.**

STEP 7

Install Window

A. Install integral flanged window per manufacturer's instructions.

Installation Methods for DuPont Flashing Products

Wood Bump-Out Frame with Integral Flanged Window

Using DuPont™ Tyvek® Fluid Applied Flashing and Joint Compound+

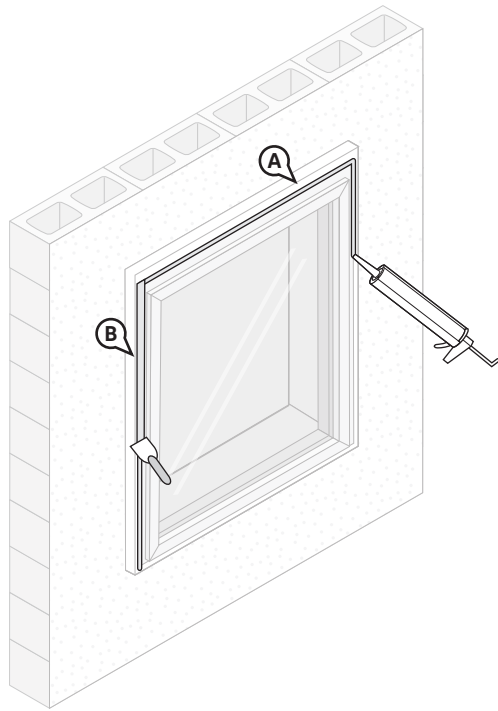

STEP 8

- A. Apply a continuous bead of **DuPont™ Tyvek® Fluid Applied Flashing and Joint Compound+** along the interface between the window flange and the wall on the jambs and head of the window.
- B. Use a trowel or brush to smooth flashing to approximately 2" wide x 60 mils thick. The **Tyvek® Fluid Applied Flashing and Joint Compound+** should extend onto the window flange a minimum of a 1/2" past the flange fasteners (approximately 1" onto either side of the flange/wall interface). Upon completion, inspect surface to ensure that **Tyvek® Fluid Applied Flashing and Joint Compound+** application is continuous and free of any voids or pinholes.

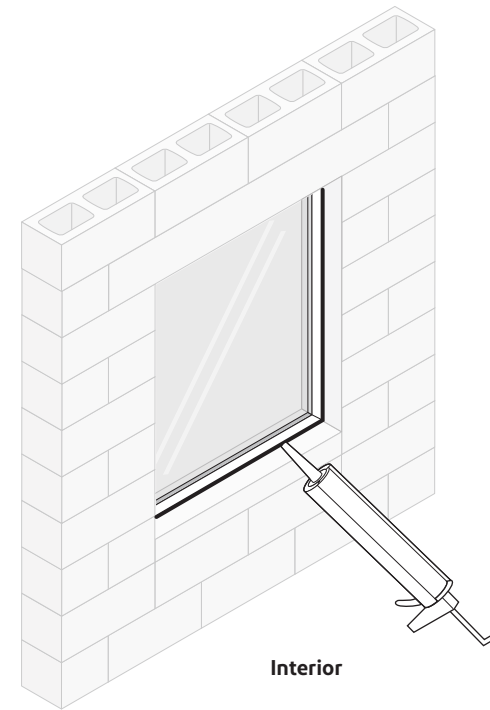

STEP 9

Create Interior Perimeter Seal

Apply a continuous bead of a [*chemically-compatible sealant*](#) (and backer rod as necessary) around the window opening at the interior. It is also acceptable to use **Great Stuff Pro™ Window & Door Polyurethane Foam Sealant**, or a chemically-compatible foam. When using **Great Stuff Pro™ Window & Door Polyurethane Foam Sealant** in perimeter openings less than 1/2", apply using the plastic extension tip for the **Great Stuff Pro™ Dispensing Gun** during installation.

NOTE: For high performance installations exceeding ASTM E1677 wind loading pressures (10.8 psf, 65 mph equivalent structural load) and ASTM E331 water infiltration resistance of 6.24 psf, a chemically-compatible sealant **must be** installed over the cured foam when using **Great Stuff Pro™ Window and Door Polyurethane Foam Sealant** or a chemically-compatible foam. Sealant should be installed over the foam between the window frame and rough opening around the entire interior perimeter. If **Great Stuff Pro™ Window and Door Polyurethane Foam Sealant** or other chemically-compatible foam extends beyond the window frame, shave the excess cured foam flush with the window frame before applying sealant. Avoid damaging the **Tyvek® Fluid Applied Flashing and Joint Compound+**.

Installation Methods for DuPont Flashing Products

Steel Stud with Integral Flanged Window

Method 1: Using DuPont™ Tyvek® Fluid Applied Flashing and Joint Compound+ and DuPont™ StraightFlash™

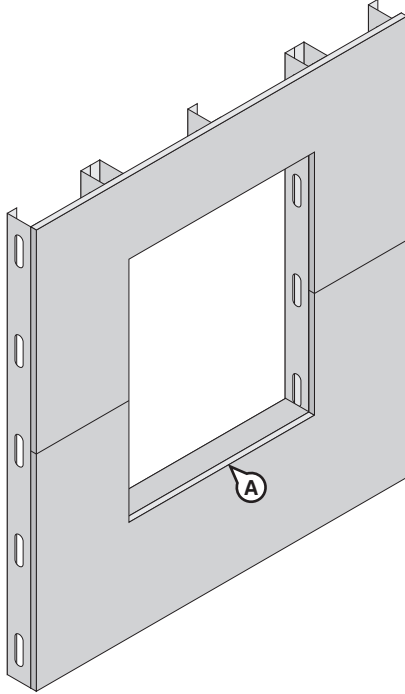

STEP 1

- A. Cut rough opening in sheathing for window. Ensure that sheathing is cut flush with, or slightly below, the sill framing to allow for positive drainage.

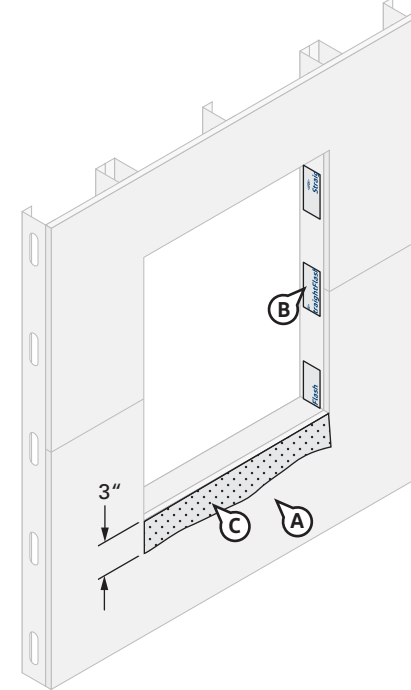

STEP 2

- A. Clean substrate of any material that could negatively affect adhesion as well as any sharp protrusions.
- B. Cover any pre-punched holes in the steel studs with patches of **StraightFlash™**.
- C. When using **StraightFlash™** at the sill of the window, apply a chemically-compatible adhesive/primer approximately 3" onto the exterior face of wall and along the interior sill for masonry and/or concrete surfaces.

NOTE: If applying to exterior gypsum sheathing, the cut edge of the gypsum should be primed using a chemically-compatible adhesive/primer on all four sides prior to application of **Tyvek® Fluid Applied Flashing and Joint Compound+**.

NOTE: A chemically-compatible adhesive/primer is required when applying **DuPont Self-Adhered Flashing Products** on concrete, masonry, and fiber faced exterior gypsum board substrates. The use of a chemically-compatible adhesive/primer, is a recommended best practice for application of **DuPont Self-Adhered Flashing Products** onto wood substrates.

Installation Methods for DuPont Flashing Products

Steel Stud with Integral Flanged Window

Method 1: Using DuPont™ Tyvek® Fluid Applied Flashing and Joint Compound+ and DuPont™ StraightFlash™

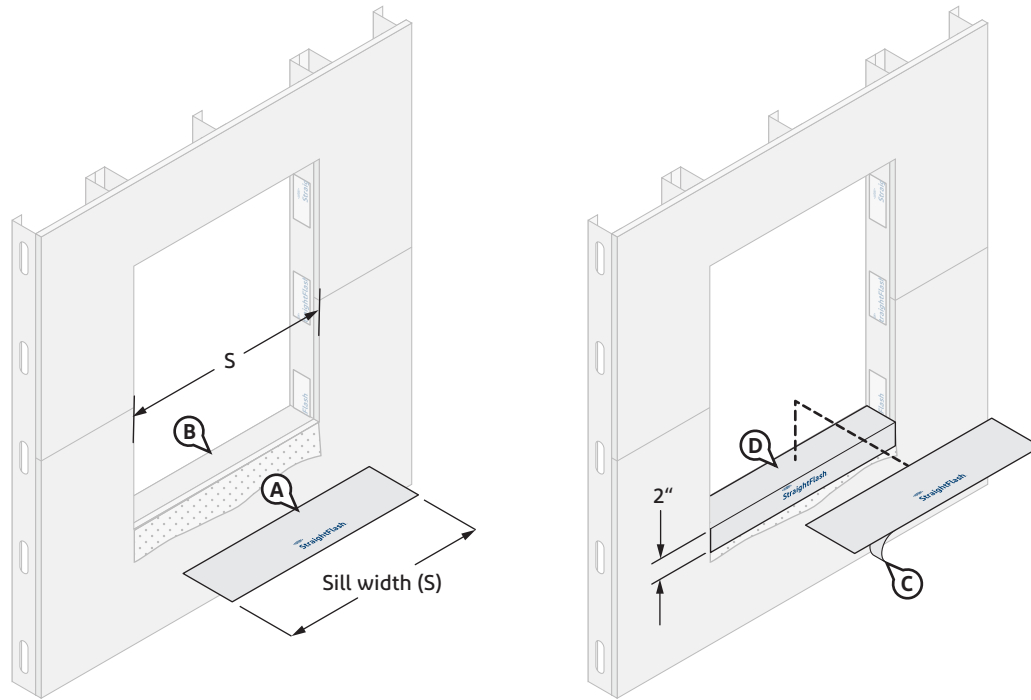

STEP 3

- Cut 9" **StraightFlash™** the width of rough opening sill (S). Ensure a minimum of 1" adhesion **BEYOND** where the back of the window frame will be located, and 2"– 3" adhesion onto the face of wall.
- Inspect installation surface to ensure surface is free of dirt or substances that could interfere with adhesion as well as any sharp protrusions.

- Remove the release paper and position **StraightFlash™** onto the sill and 2" minimum onto the face the wall.
- Apply pressure along the entire surface of **StraightFlash™** for a good bond using firm hand pressure or J-roller (or alternate tool without sharp edges such as a plastic carpet tuck tool) to assist with application of uniform pressure.

NOTE: **StraightFlash™** is not required in cases where no fasteners are being installed through the window sill.

NOTE: **DuPont™ FlexWrap™** can be used in place of **StraightFlash™**. When used, **FlexWrap™** should be cut and installed to accommodate the sill, 6" up each jamb, and 2"– 3" onto the face of wall substrate.

Installation Methods for DuPont Flashing Products

Steel Stud with Integral Flanged Window

Method 1: Using DuPont™ Tyvek® Fluid Applied Flashing and Joint Compound+ and DuPont™ StraightFlash™

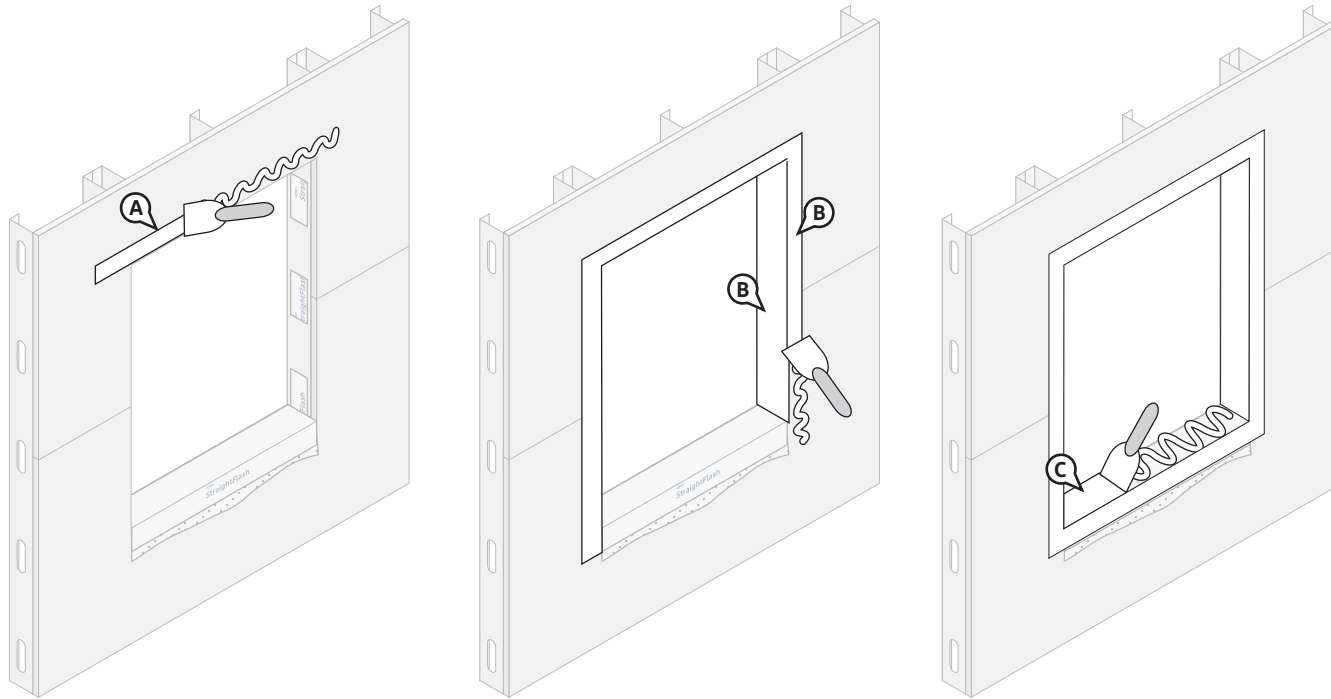

STEP 4

- A. Starting at the window head, apply **Tyvek® Fluid Applied Flashing and Joint Compound+** onto the inside surface of the rough opening and onto the face of wall. Use a trowel or brush to smooth out flashing to a thickness of approximately 25 mils. The flashing should cover the inside of the rough opening and extend a minimum of 2" onto the face of wall.
- B. Apply **Tyvek® Fluid Applied Flashing and Joint Compound+** along the rough opening of both jambs and minimum 2" onto the face of wall. Use a trowel or brush to smooth out flashing to a thickness of approximately 25 mils.

- C. Apply **Tyvek® Fluid Applied Flashing and Joint Compound+** on top of the **StraightFlash™** along the sill and a minimum 2" on the face of wall. Be sure all inside corners are filled and integrated with the **StraightFlash™**. A corner trowel may be used to smooth outside corners.

NOTE: **Tyvek® Fluid Applied Flashing and Joint Compound+** is not required along the entire sill when **StraightFlash™** is installed as previously captured, provided **Tyvek® Fluid Applied Flashing and Joint Compound+** is applied a minimum 4"– 6" along the sill from the jamb corner.

NOTE: If **DuPont™ FlexWrap™** is used along the sill, **Tyvek® Fluid Applied Flashing and Joint Compound+** is not required along the sill to jamb interface but must be applied to head and jamb areas.

Method 1: Using DuPont™ Tyvek® Fluid Applied Flashing and Joint Compound+ and

Installation Methods for DuPont Flashing Products Steel Stud with Integral Flanged Window

DuPont™ StraightFlash™

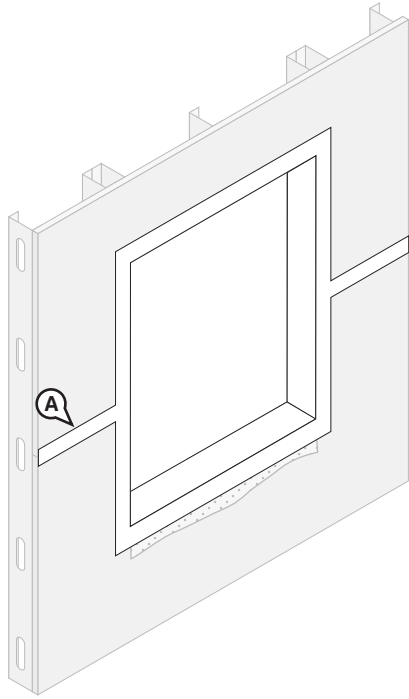

STEP 5

- A. Treat sheathing seam joints with **Tyvek® Fluid Applied Flashing and Joint Compound+** in accordance with the [Joint Treatment Methods](#) where applicable.
- B. Upon completion, inspect surface, including all corners, to ensure that **Tyvek® Fluid Applied Flashing and Joint Compound+** is continuous and **free of any voids or pinholes**. **NOTE:** DuPont™ Tyvek® Fluid Applied WB+™ may be applied over and integrated with **Tyvek® Fluid Applied Flashing and Joint Compound+** once a tack-free skin has formed. Skin time is 1-2 hrs at 70°F (20°C), 50% RH.

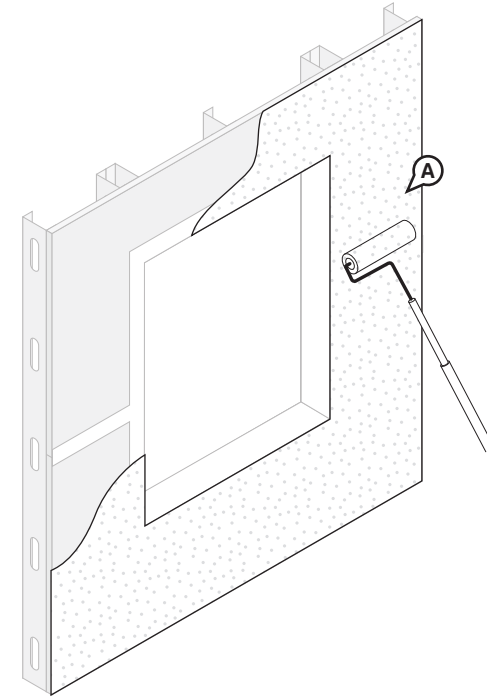

STEP 6

- A. Install **Tyvek® Fluid Applied WB+™** up to the edge of the rough opening, overlapping the **Tyvek® Fluid Applied Flashing and Joint Compound+**.

NOTE: When spraying, the outer edge of **DuPont Self-Adhered Flashing Product** should be treated with **Tyvek® Fluid Applied Flashing and Joint Compound+** or **Tyvek® Fluid Applied WB+™** tapered to the wall substrate to help ensure installation is free of pinholes and voids.

Refer to the [DuPont™ Tyvek® Fluid Applied WB+™ Installation Instructions](#) section of this document. Exterior insulation and/or cladding may be installed once the membrane has cured sufficiently to resist damage during installation. Skin time is 1 – 2 hours, and 25 mil is workable in 24 hours at 70°F (20°C), 50% RH.

Installation Methods for DuPont Flashing Products

Steel Stud with Integral Flanged Window

Method 1: Using DuPont™ Tyvek® Fluid Applied Flashing and Joint Compound+ and DuPont™ StraightFlash™

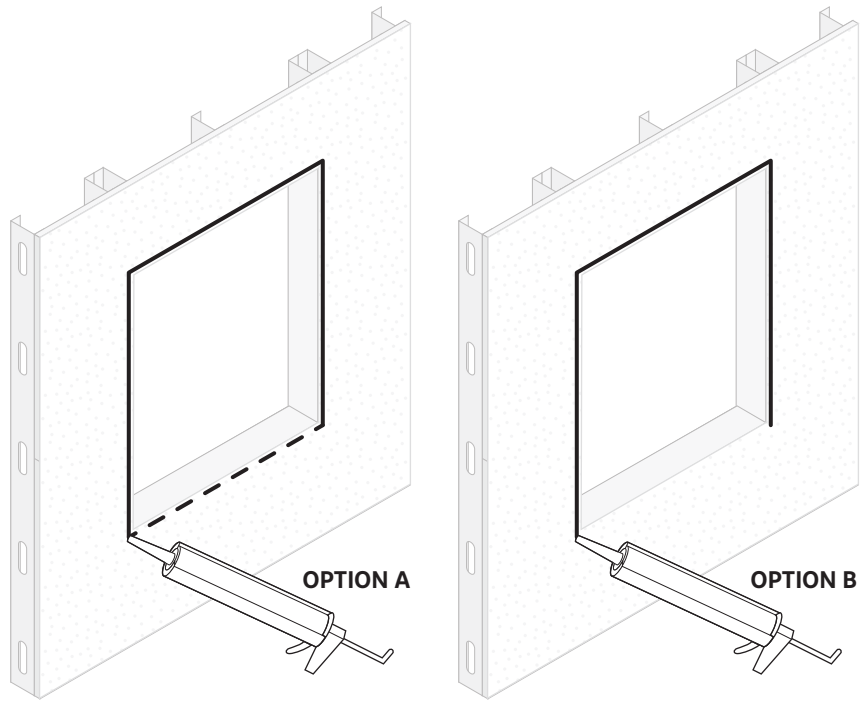

STEP 7

After DuPont™ Tyvek® Fluid Applied WB+™ has cured, apply a [chemically-compatible sealant](#) using one of the following options.

OPTION A: Apply a continuous bead of a [chemically-compatible sealant](#) at window head and jambs to wall or back side of window mounting flange. To allow for drainage, **DO NOT APPLY** continuous sealant bead along sill. Ensure a minimum 2" wide drainage gap in the sealant bead within 4" from each corner of the jamb-sill interface. Continue applying sealant along the sill with additional 2" wide (min.) drainage gaps for every 6"– 12" (on center) of sill width.

OPTION B: Apply a continuous bead of a [chemically-compatible sealant](#) at window head and jambs to wall or back side of window flanges. **To allow for drainage, do not apply sealant bead along sill.**

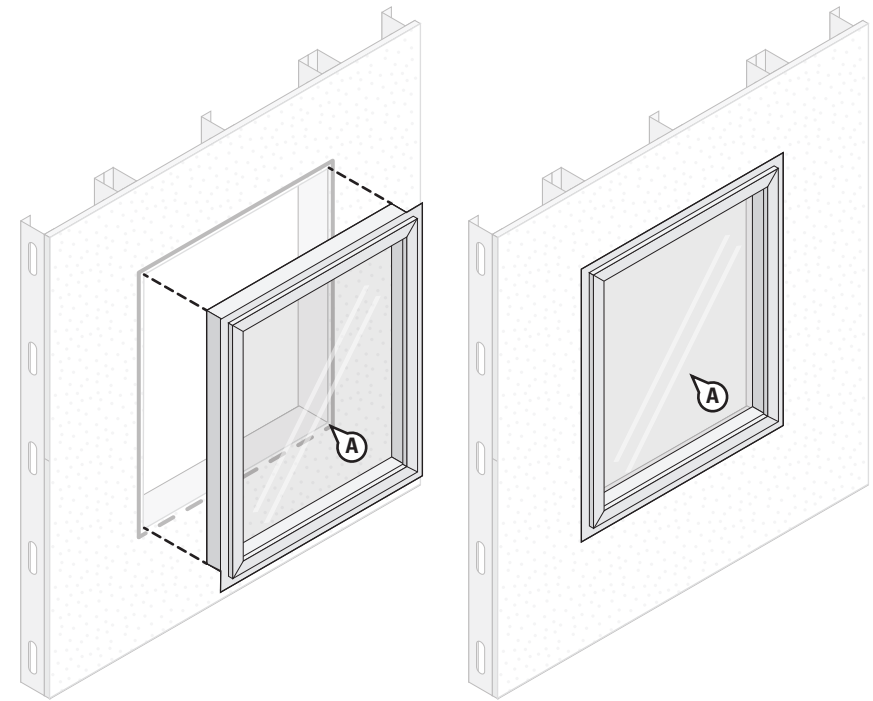

STEP 8

A. Install window per manufacturer's installation instructions.

Installation Methods for DuPont Flashing Products

Steel Stud with Integral Flanged Window

Method 1: Using DuPont™ Tyvek® Fluid Applied Flashing and Joint Compound+ and DuPont™ StraightFlash™

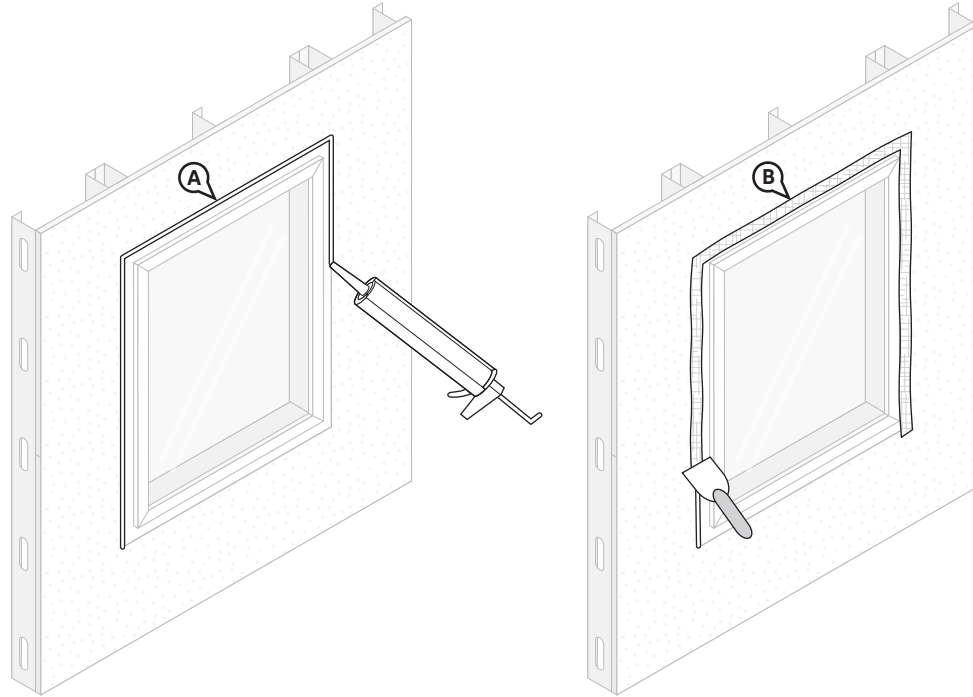

STEP 9

A. Apply a continuous bead of **Tyvek® Fluid Applied Flashing and Joint Compound+** along the interface between the window flange and the wall on the jambs and head of the window.

B. Use a trowel to smooth **Tyvek® Fluid Applied Flashing and Joint Compound+** to approximately 2" wide x 60 mils thick. The **Tyvek® Fluid Applied Flashing and Joint Compound+** should extend onto the window flange a minimum of a 1/2" past the flange fasteners (approximately 1" onto either side of the flange/wall interface). Upon completion, inspect surface to ensure that **Tyvek® Fluid Applied Flashing and Joint Compound+** application is continuous and **free of any voids or pinholes**.

Installation Methods for DuPont Flashing Products

Steel Stud with Integral Flanged Window

Method 1: Using DuPont™ Tyvek® Fluid Applied Flashing and Joint Compound+ and DuPont™ StraightFlash™

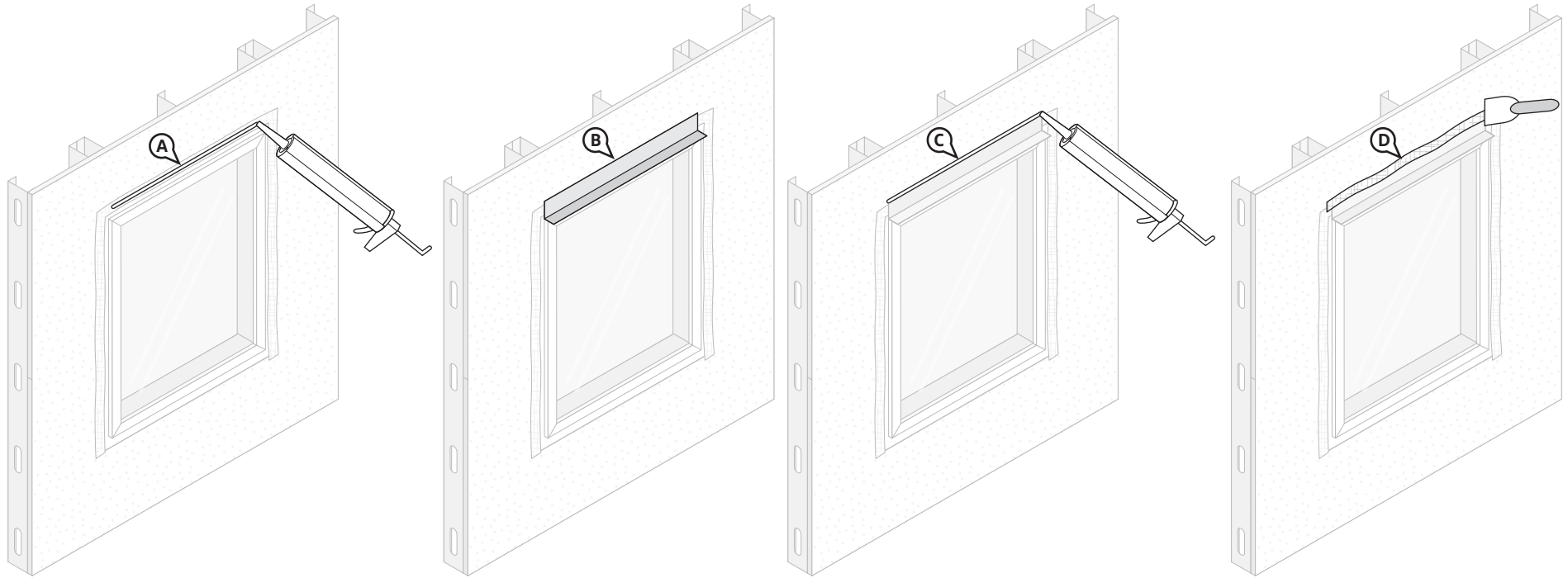

STEP 10

Drip Cap Installation

NOTE: The following steps may be used to install a drip cap over the head flashing for any of the window types included in this guide.

A. Apply a wet bed of **Tyvek® Fluid Applied Flashing and Joint Compound+** along the location where the fastener for the drip cap will be positioned. Wet bed can be troweled to 25 mils ±5 mils.

- B. Install metal drip cap per project details and/or manufacturer's recommendation.
- C. Apply **Tyvek® Fluid Applied Flashing and Joint Compound+** along the top edge of the metal drip cap.
- D. Trowel **Tyvek® Fluid Applied Flashing and Joint Compound+** to continuous 25 mils. Ensure a minimum of 1" of coverage onto either side of the drip cap to wall interface.

Installation Methods for DuPont Flashing Products

Steel Stud with Integral Flanged Window

Method 1: Using DuPont™ Tyvek® Fluid Applied Flashing and Joint Compound+ and DuPont™ StraightFlash™

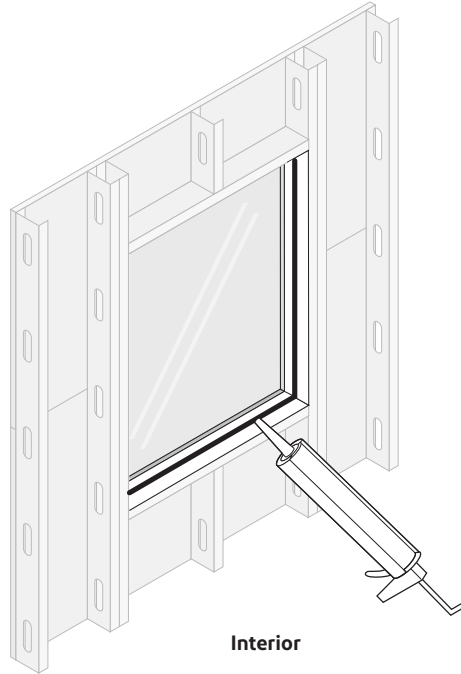

STEP 11

Create Interior Perimeter Seal

Apply a continuous bead of a [chemically-compatible sealant](#) (and backer rod as necessary) around the window opening at the interior. It is also acceptable to use **Great Stuff Pro™ Window & Door Polyurethane Foam Sealant**, or a chemically-compatible foam. When using **Great Stuff Pro™ Window & Door Polyurethane Foam Sealant** in perimeter openings less than 1/2", apply using the plastic extension tip for the **Great Stuff Pro™ Dispensing Gun** during installation.

NOTE: For high performance installations exceeding ASTM E1677 wind loading pressures (10.8 psf, 65 mph equivalent structural load) and ASTM E331 water infiltration resistance of 6.24 psf, a chemically-compatible sealant **must be** installed over the cured foam when using **Great Stuff Pro™ Window and Door Polyurethane Foam Sealant** or a chemically-compatible foam. Sealant should be installed over the foam between the window frame and rough opening around the entire interior perimeter. If **Great Stuff Pro™ Window and Door Polyurethane Foam Sealant** or other chemically-compatible foam extends beyond the window frame, shave the excess cured foam flush with the window frame before applying sealant. Avoid damaging the **Tyvek® Fluid Applied Flashing and Joint Compound+** and/or **DuPont Self-Adhered Flashing Products**.

Installation Methods for DuPont Flashing Products

Steel Stud with Integral Flanged Window

Method 2: Self-Adhered Flashing Using DuPont™ FlexWrap™ and DuPont™ StraightFlash™

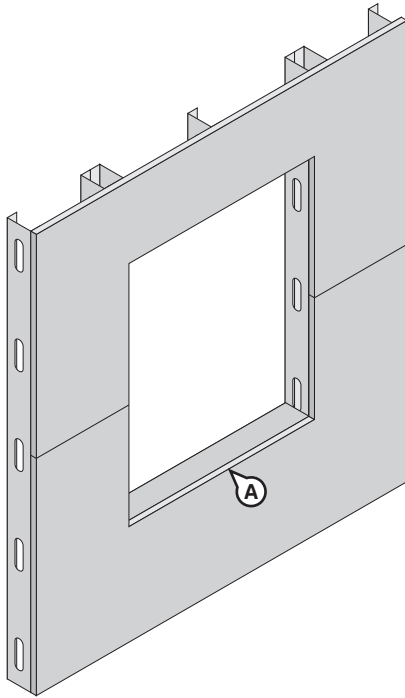

STEP 1

A. Cut rough opening in sheathing for window. Ensure that sheathing is cut flush with, or slightly below, the sill framing to allow for positive drainage.

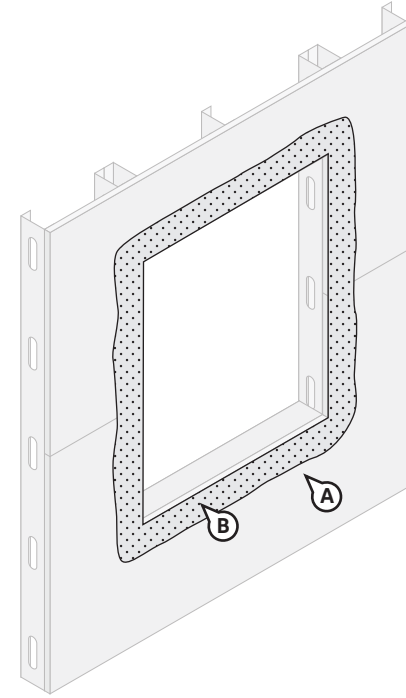

STEP 2

- A. Clean substrate of any material that could negatively affect adhesion, as well as any sharp protrusions.
- B. Apply a [chemically-compatible adhesive/primer](#) approximately 3" onto the exterior face of wall.

Installation Methods for DuPont Flashing Products

Steel Stud with Integral Flanged Window

Method 2: Self-Adhered Flashing Using DuPont™ FlexWrap™ and DuPont™ StraightFlash™

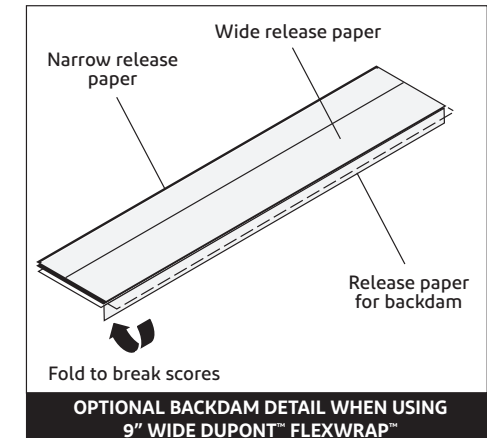
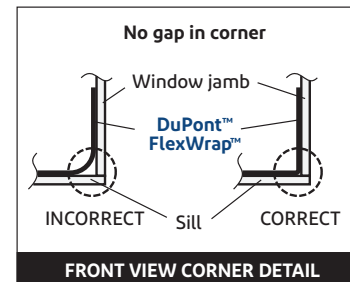
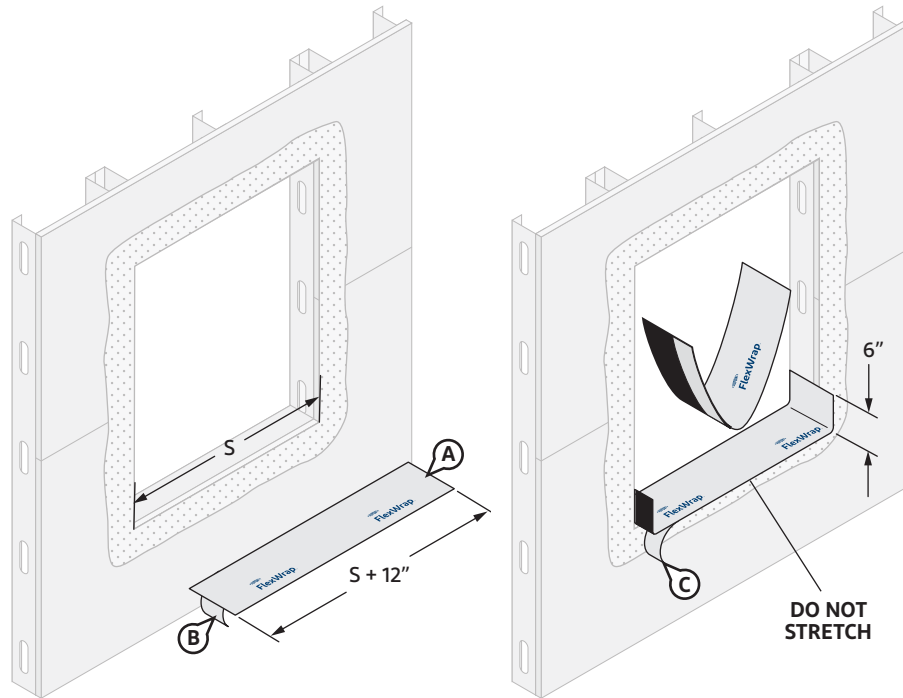

STEP 3

- Cut **FlexWrap™** at least 12" **LONGER** than the width of rough opening sill (S). Use roll widths sufficient to achieve a minimum of 1" adhesion **BEYOND** where the back of the window frame will be located, ensuring 2"– 3" adhesion onto the face of wall.
- Remove the wide piece of release paper.
- Remove wide piece of release paper. Position on horizontal sill by aligning the inside edge of the narrow release paper with the face of wall to ensure 2"– 3" of the **FlexWrap™** will be adhered to the face of wall with a minimum of 6" up each jamb. Adhere into rough opening.

Optional Back Dam: Fold 9" **FlexWrap™** to break perforation. Remove center piece of

release paper. Cover horizontal sill to accommodate back dam as appropriate, and adhere into rough opening along sill and up jambs (min 6" on each side). Leave 1" release paper on **FlexWrap™** inside rough opening to finish back dam after window installation.

NOTE: Use of the optional back dam **must not** interfere with the installation of a continuous interior perimeter seal.

- Remove the remaining release paper.

NOTE: DuPont™ Tyvek® Commercial Certified Installers may install a 3-piece head (and sill) detail for window openings less than 6 ft wide. Installers who **are not** DuPont™ Tyvek® Commercial Certified Installers should refer to the [Special Considerations](#) section for more information regarding the 3-piece head/sill detail. Contact your local DuPont Building Envelope Specialist for more information about the Certified Installer program.

Installation Methods for DuPont Flashing Products Steel Stud with Integral Flanged Window

Method 2: Self-Adhered Flashing Using DuPont™ FlexWrap™ and DuPont™ StraightFlash™

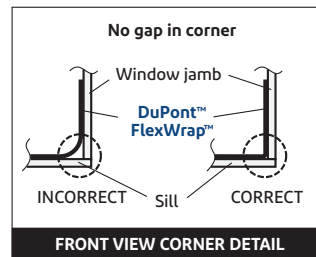
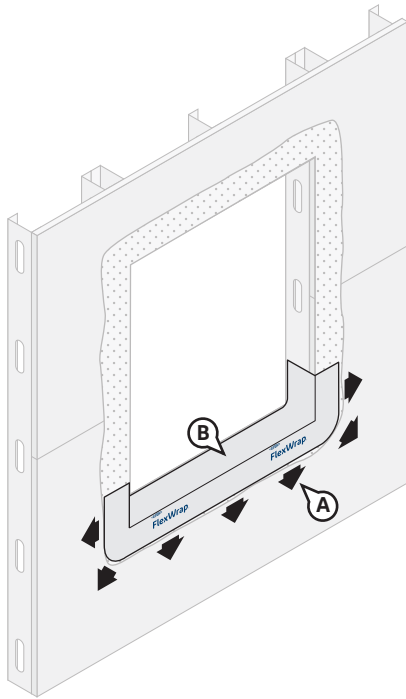

STEP 4

- Fan out the **FlexWrap™** at corners and adhere onto face of wall. Continue adhering onto face of wall along sill.
- Firmly press sill flashing to ensure full adhesion on all surfaces. Eliminate wrinkles and bubbles by smoothing surface and repositioning as necessary.

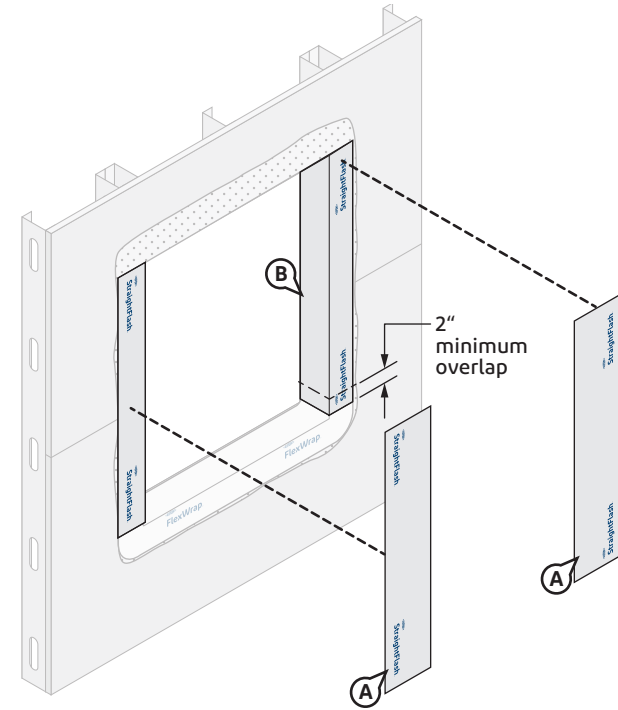

STEP 5

- Cut two pieces of 9" **StraightFlash™** the vertical length of the rough opening. Jamb flashing should be long enough to overlap the sill flashing by at least 2" and be overlapped by future head flashing by at least 2".
- Wrap the **StraightFlash™** into the rough opening at each jamb and 2"– 3" onto the face of wall. As a general reference, **DuPont Self-Adhered Flashing Products** should align with the interior edge of the jamb framing.

Installation Methods for DuPont Flashing Products

Steel Stud with Integral Flanged Window

Method 2: Self-Adhered Flashing Using DuPont™ FlexWrap™ and DuPont™ StraightFlash™

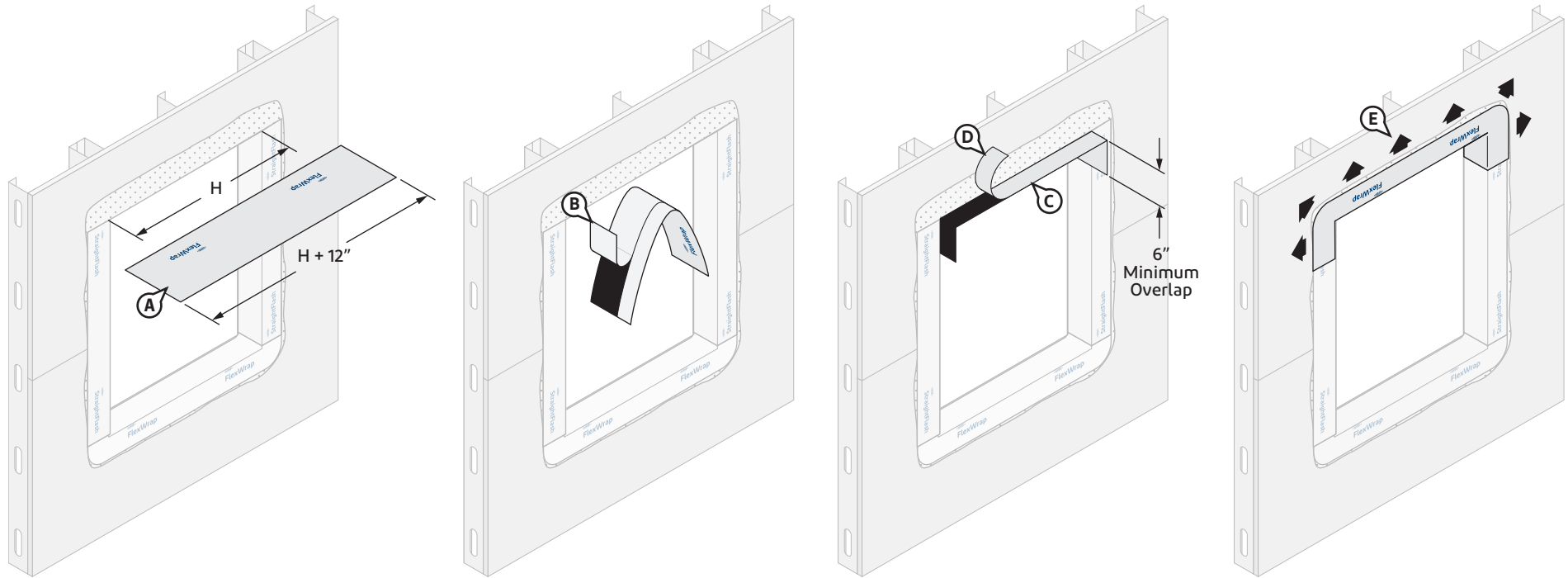

STEP 6

- Cut **FlexWrap™** at least 12" **LONGER** than the width of rough opening head (H). Use roll widths sufficient to achieve a minimum of 1" adhesion **BEYOND** where the back of the window frame will be located, ensuring 2"– 3" adhesion onto the face of wall.
- Fold the **FlexWrap™** in half lengthwise to create a slight crease at the center. Remove the wide piece of release paper on one side of the fold. Align the inside edge of the narrow release paper with the face of wall to ensure 2"– 3" of the **FlexWrap™** will be adhered to the face of wall.
- Starting at the crease, adhere the exposed butyl adhesive to the center of the head and a minimum of 6" down the jamb. Remove the remaining release paper and continue process of adhering **FlexWrap™** along the head of the rough opening and 6" down the opposite jamb.
- Remove the remaining release paper.
- Fan out the **FlexWrap™** at corners and adhere onto face of wall. Continue adhering onto face of wall along the head. Apply pressure along entire surface of flashing for a good bond using firm hand pressure, J-roller, or alternate tool without sharp edges (such as a plastic carpet tuck tool) to assist with application of uniform pressure.

NOTE: DuPont™ Tyvek® Commercial Certified Installers may install a 3-piece head (and sill) detail for window openings less than 6 ft wide. Installers who **are not** DuPont™ Tyvek® Commercial Certified Installers should refer to the [Special Considerations](#) section for more information regarding the 3-piece head/sill detail. Contact your local DuPont Building Envelope Specialist for more information about the Certified Installer program.

Installation Methods for DuPont Flashing Products

Steel Stud with Integral Flanged Window

Method 2: Self-Adhered Flashing Using DuPont™ FlexWrap™ and DuPont™ StraightFlash™

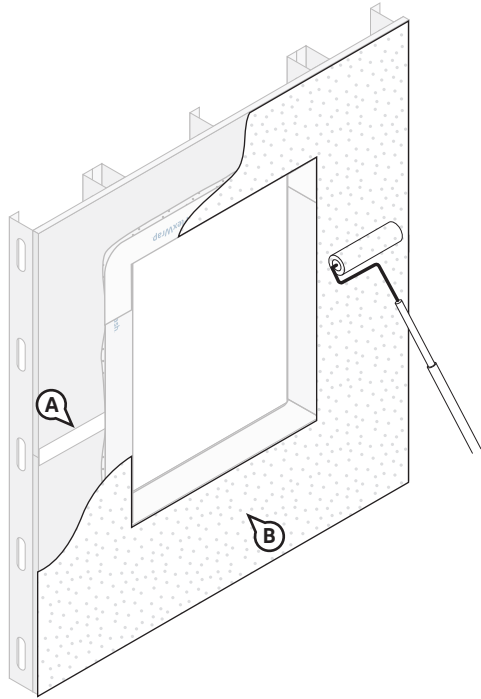

STEP 7

- A. Treat sheathing seam joints with **DuPont™ Tyvek® Fluid Applied Flashing and Joint Compound+** in accordance with the [Joint Treatment Methods](#) where applicable.
- B. Install **DuPont™ Tyvek® Fluid Applied WB+™** onto wall at 25 mils thick, overlapping the **DuPont Self-Adhered Flashing Product** up to the edge of the rough opening. Upon completion, inspect all surfaces to ensure that they are covered and free of any voids or pinholes.

NOTES:

- **Tyvek® Fluid Applied WB+™** may be applied over and integrated with **Tyvek® Fluid Applied Flashing and Joint Compound+** once a tack-free skin has formed. Skin time is 1–2 hours, and 25 mil is workable in 24 hours at 70°F (20°C), 50% RH.
- When spraying, the outer edge of **DuPont Self-Adhered Flashing Product** should be treated with **DuPont™ Tyvek® Fluid Applied Flashing and Joint Compound+**, and tapered to wall substrate to help ensure installation is free of pinholes and voids..
- Refer to the [DuPont™ Tyvek® Fluid Applied WB+™ Installation Instructions](#) section of this document. Exterior insulation and/or cladding may be installed once the membrane has cured sufficiently to resist damage during installation.

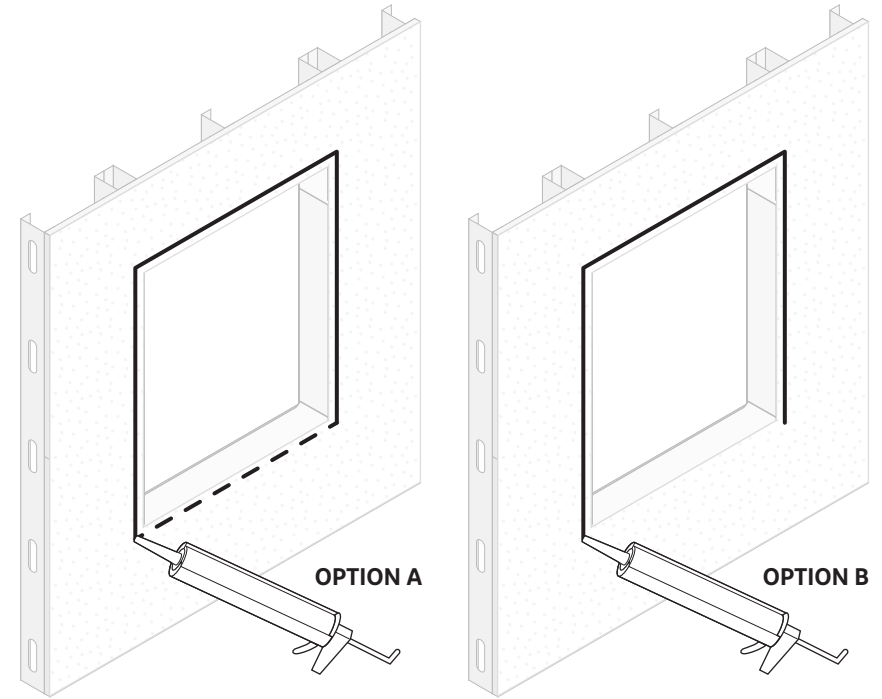

STEP 8

After **Tyvek® Fluid Applied WB+™** has cured, one of the sealant options **MUST** be used prior to installation of the integral flanged window.

OPTION A: Apply a continuous bead of a [chemically-compatible sealant](#) at window head and jambs to wall or back side of window mounting flange. To allow for drainage, **DO NOT APPLY** continuous sealant bead along sill. Ensure a minimum 2" wide drainage gap in the sealant bead within 4" from each corner of the jamb-sill interface. Continue applying sealant along the sill with additional 2" wide (min.) drainage gaps for every 6"– 12" (on center) of sill width.

OPTION B: Apply a continuous bead of a [chemically-compatible sealant](#) at window head and jambs to wall or back side of window flanges. **To allow for drainage, do not apply sealant bead along sill.**

Installation Methods for DuPont Flashing Products

Steel Stud with Integral Flanged Window

Method 2: Self-Adhered Flashing Using DuPont™ FlexWrap™ and DuPont™ StraightFlash™

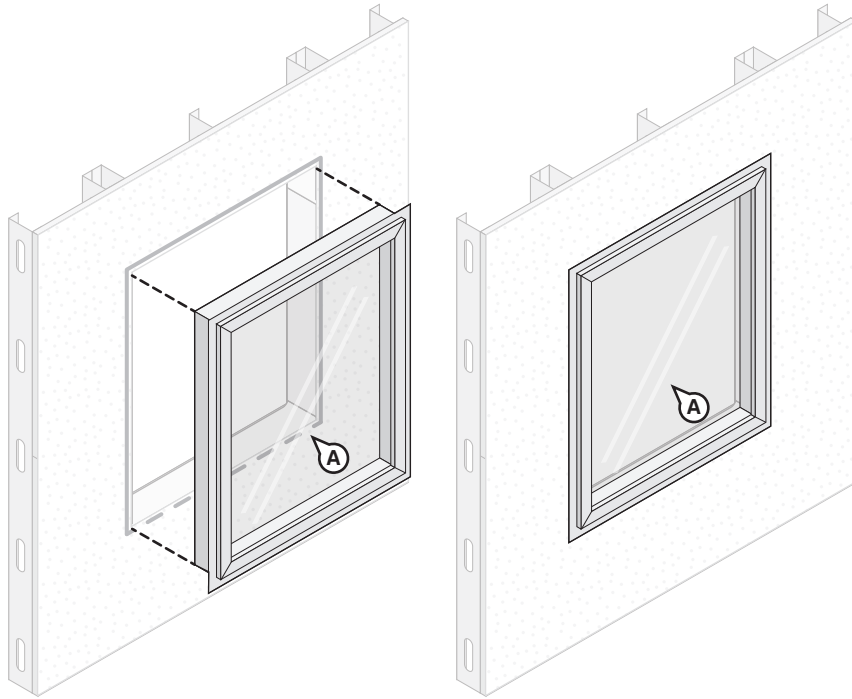

STEP 9

- A. Install window per manufacturer's installation instructions.

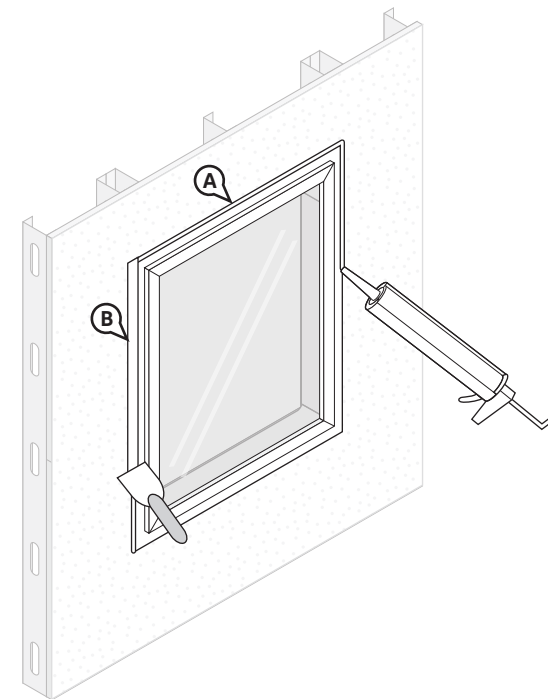

STEP 10

- A. Apply a continuous bead of **DuPont™ Tyvek® Fluid Applied Flashing and Joint Compound+** along the interface between the window flange and the wall on the jambs and head of the window.
- B. Use a trowel to smooth flashing to approximately 2" wide x 60 mils thick. The **Tyvek® Fluid Applied Flashing and Joint Compound+** should extend onto the window flange a minimum of a 1/2" past the flange fasteners (approximately 1" onto either side of the flange / wall interface). Upon completion, inspect surface to ensure that **Tyvek® Fluid Applied Flashing and Joint Compound+** application is continuous and **free of any voids or pinholes**.

Installation Methods for DuPont Flashing Products

Steel Stud with Integral Flanged Window

Method 2: Self-Adhered Flashing Using DuPont™ FlexWrap™ and DuPont™ StraightFlash™

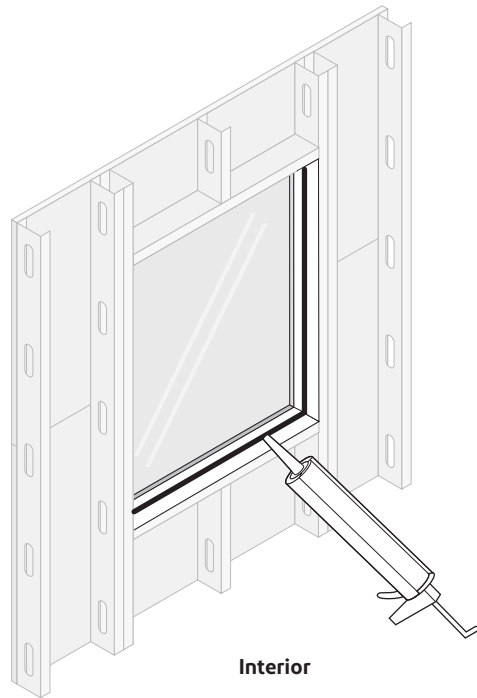

STEP 11

Create Interior Perimeter Seal

Apply a continuous bead of a [chemically-compatible sealant](#) (and backer rod as necessary) around the window opening at the interior. It is also acceptable to use **Great Stuff Pro™ Window & Door Polyurethane Foam Sealant**, or chemically-compatible foam. When using **Great Stuff Pro™ Window & Door Polyurethane Foam Sealant** in perimeter openings less than 1/2", apply using the plastic extension tip for the **Great Stuff Pro™ Dispensing Gun** during installation.

NOTE: For high performance installations exceeding ASTM E1677 wind loading pressures (10.8 psf, 65 mph equivalent structural load) and ASTM E331 water infiltration resistance of 6.24 psf, a chemically-compatible sealant **must be** installed over the cured foam when using **Great Stuff Pro™ Window and Door Polyurethane Foam Sealant** or a chemically-compatible foam. Sealant should be installed over the foam between the window frame and rough opening around the entire interior perimeter. If **Great Stuff Pro™ Window and Door Polyurethane Foam Sealant** or other chemically-compatible foam extends beyond the window frame, shave the excess cured foam flush with the window frame before applying sealant. Avoid damaging the **DuPont Self-Adhered Flashing Products**.

Installation Methods for DuPont Flashing Products

Steel Stud with Integral Flanged Window

Method 3: Alternate Self-Adhered Flashing Option Using DuPont™ StraightFlash™ Only

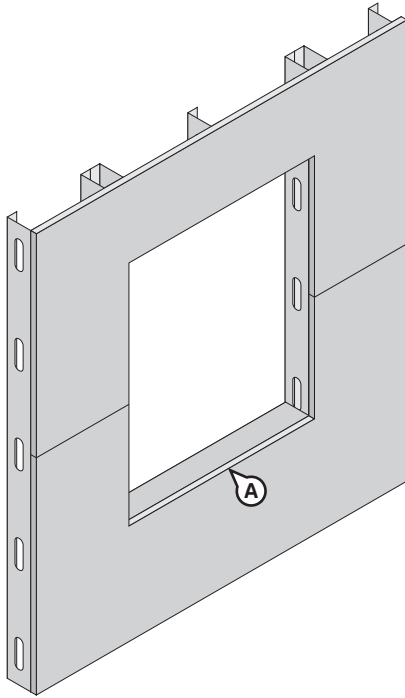

STEP 1

- A. Cut rough opening in sheathing for window. Ensure that sheathing is cut flush with, or slightly below, the sill framing to allow for positive drainage.

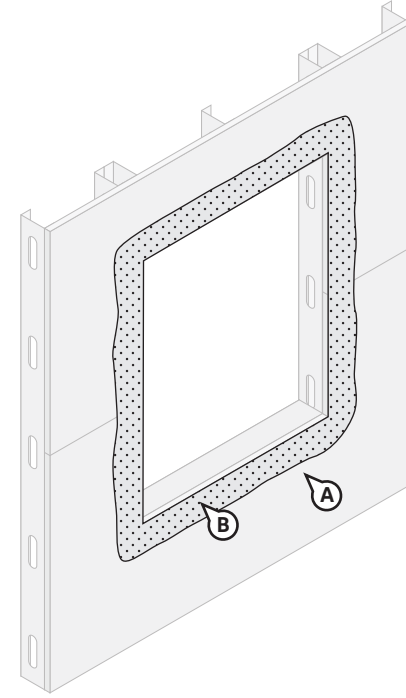

STEP 2

- A. Clean substrate of any material that could negatively affect adhesion, as well as any sharp protrusions.
- B. Apply a [*chemically-compatible adhesive/primer*](#) approximately 3" onto the exterior face of wall.

Installation Methods for DuPont Flashing Products

Steel Stud with Integral Flanged Window

Method 3: Alternate Self-Adhered Flashing Option Using DuPont™ StraightFlash™ Only

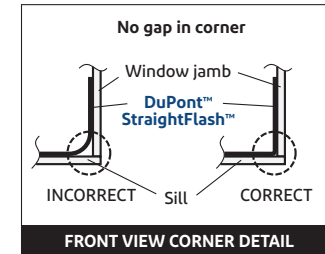
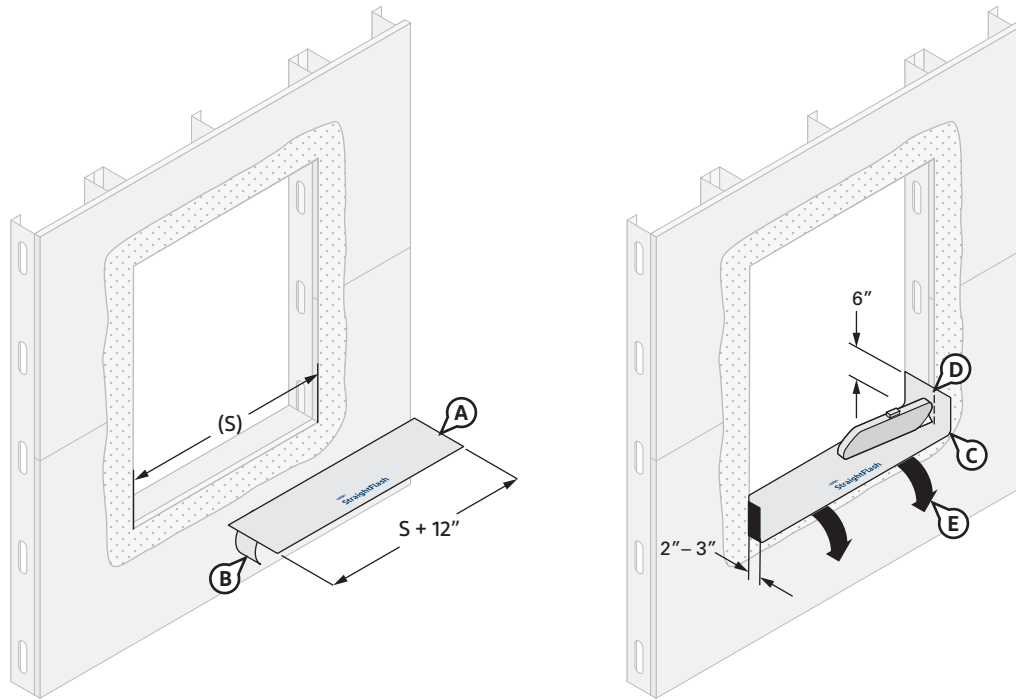

STEP 3

- A. Cut a piece of 9" **StraightFlash™** the length of the sill (S) plus an additional 12".
- B. Install the **StraightFlash™** by removing the widest strip of release paper, and aligning the flashing so it extends 1" **BEYOND** where the back of the window frame will be located, 2"– 3" onto the face of wall, and 6" up the jambs.
- C. Secure **StraightFlash™** tightly into the corners by first working it in along the sill before adhering it up the jambs. (See front view corner detail).
- D. Cut the jamb portion of the sill flashing even with the face of wall.
- E. With release paper still attached, fold flashing down onto the face of wall.

Installation Methods for DuPont Flashing Products

Steel Stud with Integral Flanged Window

Method 3: Alternate Self-Adhered Flashing Option Using DuPont™ StraightFlash™ Only

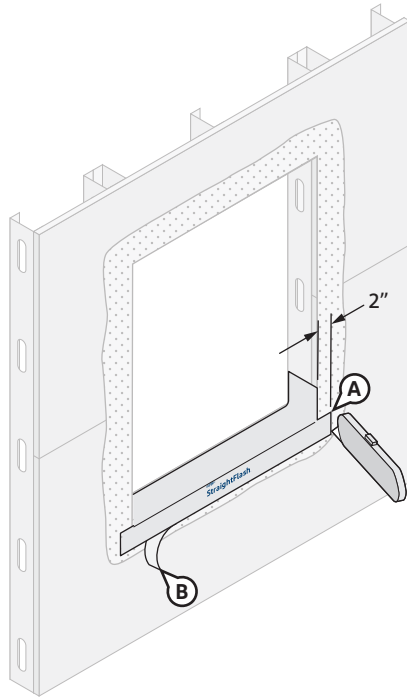

STEP 4

- A. Flaps created from vertical cuts in **StraightFlash™** should be trimmed so they do not extend more than 2" beyond jamb rough opening onto the face of wall.
- B. Remove remaining release paper and firmly press flashing onto the face of wall.

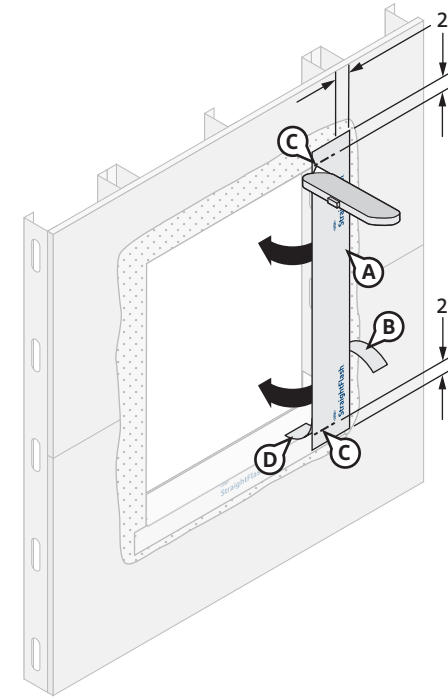

STEP 5

- A. Prepare the jamb flashing by cutting two pieces of **StraightFlash™** that are 4" longer than the jamb length.
- B. Use perforated release paper that allows **StraightFlash™** installed along the jambs to be aligned with **StraightFlash™** on sill that extends onto face of wall. Place the flashing onto the face of wall so that it extends a minimum of 2" past the jamb, head, and sill of the rough opening.
- C. Cut the **StraightFlash™** along the head and the sill of the rough opening. Flaps created from horizontal cuts in **StraightFlash™** should be trimmed so they do not extend more than 2"- 3" along the face of bump-out framing beyond sill-to-jamb and head-to-jamb interfaces.
- D. Remove the remaining release paper. Fold the flashing into the rough opening and adhere it to the jamb.

Installation Methods for DuPont Flashing Products

Steel Stud with Integral Flanged Window

Method 3: Alternate Self-Adhered Flashing Option Using DuPont™ StraightFlash™ Only

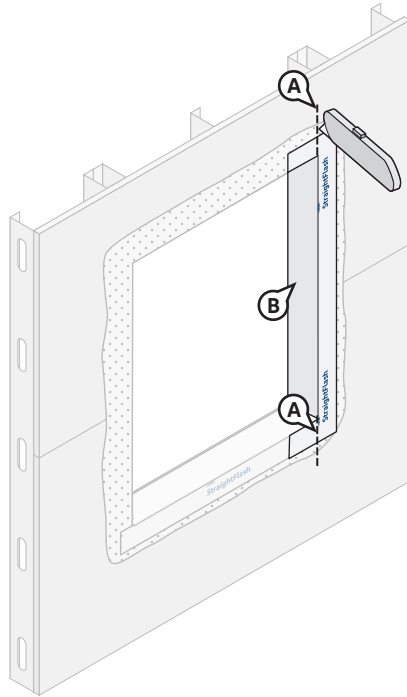

STEP 6

- A. Cut vertically along the remaining release paper and remove the excess flashing from the head and the sill. While trimming excess, ensure previously installed **StraightFlash™** remains continuous without surface cuts and/or gouges.
- B. Apply firm pressure along the entire surface to ensure full adhesion on all surfaces.

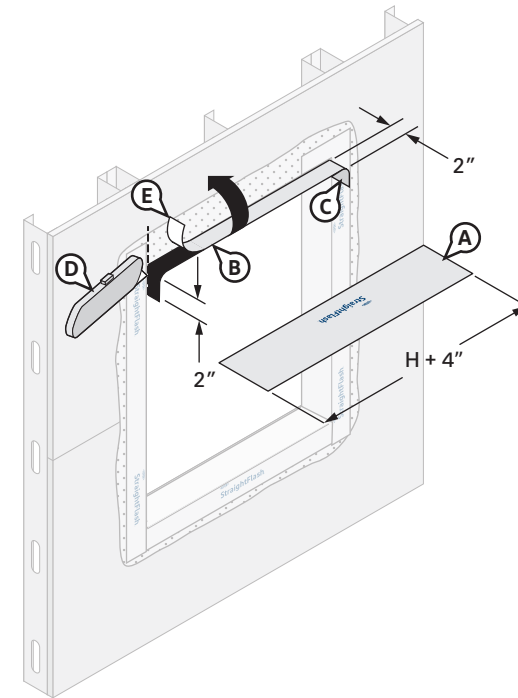

STEP 7

- A. Cut a piece of **StraightFlash™** that is at least 4" longer than the length of the rough opening head (H).
- B. Install the **StraightFlash™** by removing the widest strip of release paper, and aligning the flashing so it extends 2"– 3" onto the face of wall and overlaps the jamb flashing by at least 2".
- C. Secure flashing tightly into the corners by first working it in along the head before adhering it down the jambs.
- D. Cut the jamb portion of the head flashing even with the face of wall.
- E. Remove the remaining release paper, fold the flashing up, and firmly press flashing onto the face of wall and jamb flashing overlaps. Apply pressure along entire surface of flashing for a good bond using firm hand pressure, J-roller, or alternate tool without sharp edges (such as a plastic carpet tuck tool) to assist with application of uniform pressure.

Installation Methods for DuPont Flashing Products

Steel Stud with Integral Flanged Window

Method 3: Alternate Self-Adhered Flashing Option Using DuPont™ StraightFlash™ Only

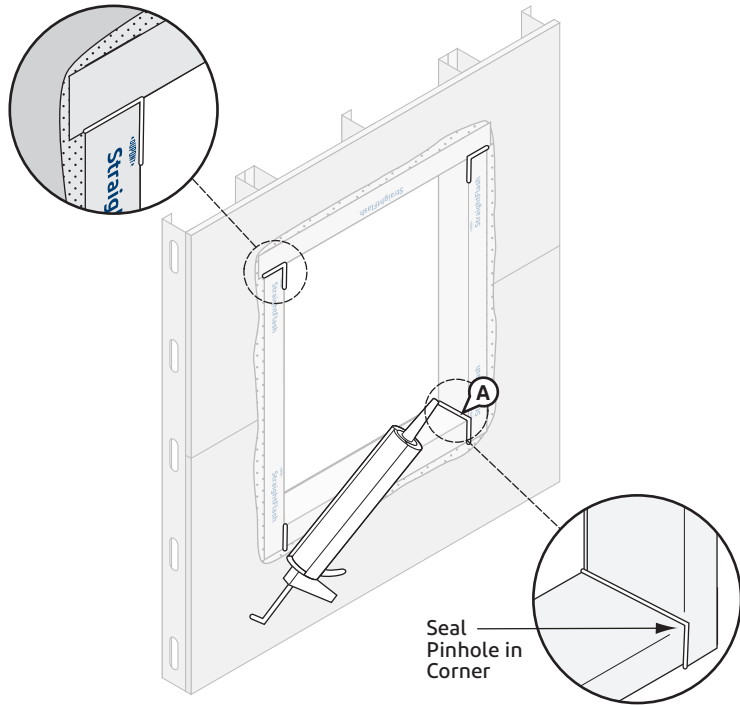

STEP 8

A. Seal all four inside corners with **DuPont™ Tyvek® Fluid Applied Flashing and Joint Compound+** or a *chemically-compatible sealant*. Extend applied product approximately 1/2" onto the face of wall flashing.

NOTE: Be sure that the pinholes in the flashing corners are fully covered with sealant.

NOTE: **DuPont™ Tyvek® Fluid Applied Products** may be overcoated once a tack-free skin has formed. Skin time is 1-2 hrs at 70°F (20°C), 50% RH.

STEP 9

A. Treat sheathing seam joints with **DuPont™ Tyvek® Fluid Applied Flashing and Joint Compound+** in accordance with the [Joint Treatment Methods](#) where applicable.

B. Install **DuPont™ Tyvek® Fluid Applied WB+™** onto wall at 25 mils thick, overlapping the **DuPont Self-Adhered Flashing Product** up to the edge of the rough opening. Upon completion, inspect all surfaces to ensure that they are covered and free of any voids or pinholes.

NOTES:

- **Tyvek® Fluid Applied WB+™** may be applied over and integrated with **Tyvek® Fluid Applied Flashing and Joint Compound+** once a tack-free skin has formed. Skin time is 1–2 hours, and 25 mil is workable in 24 hours at 70°F (20°C), 50% RH.
- When spraying, the outer edge of **DuPont Self-Adhered Flashing Product** should be treated with **DuPont™ Tyvek® Fluid Applied Flashing and Joint Compound+**, and tapered to wall substrate to help ensure installation is free of pinholes and voids.
- Refer to the [DuPont™ Tyvek® Fluid Applied WB+™ Installation Instructions](#) section of this document. Exterior insulation and/or cladding may be installed once the membrane has cured sufficiently to resist damage during installation.

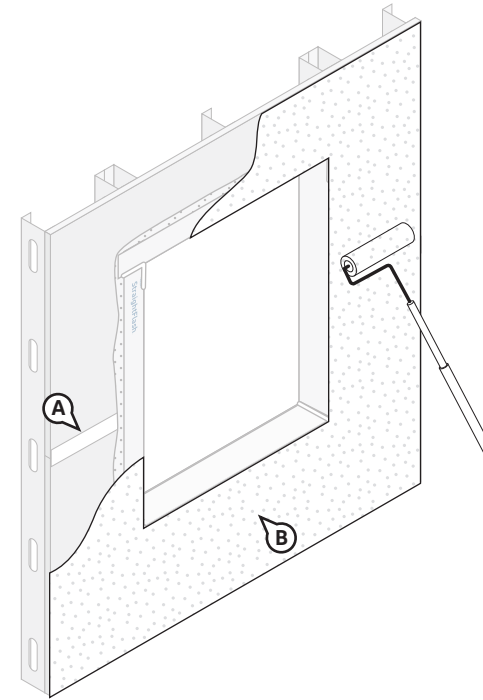

Installation Methods for DuPont Flashing Products

Steel Stud with Integral Flanged Window

Method 3: Alternate Self-Adhered Flashing Option Using DuPont™ StraightFlash™ Only

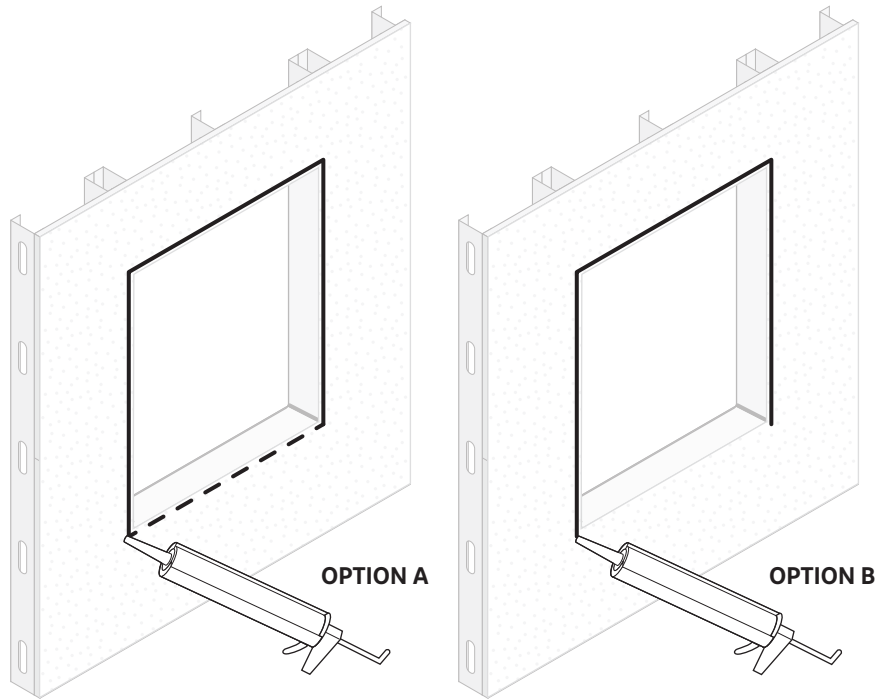

STEP 10

After the **DuPont™ Tyvek® Fluid Applied WB+™** has cured, one of the sealant options captured must be used prior to installation of the integral flanged window.

OPTION A: Apply a continuous bead of a [chemically-compatible sealant](#) at window head and jambs to wall or back side of window mounting flange. To allow for drainage, **DO NOT APPLY** continuous sealant bead along sill. Ensure a minimum 2" wide drainage gap in the sealant bead within 4" from each corner of the jamb-sill interface. Continue applying sealant along the sill with additional 2" wide (min.) drainage gaps for every 6"– 12" (on center) of sill width.

OPTION B: Apply a continuous bead of a [chemically-compatible sealant](#) at window head and jambs to wall or back side of window flanges. **To allow for drainage, do not apply sealant bead along sill.**

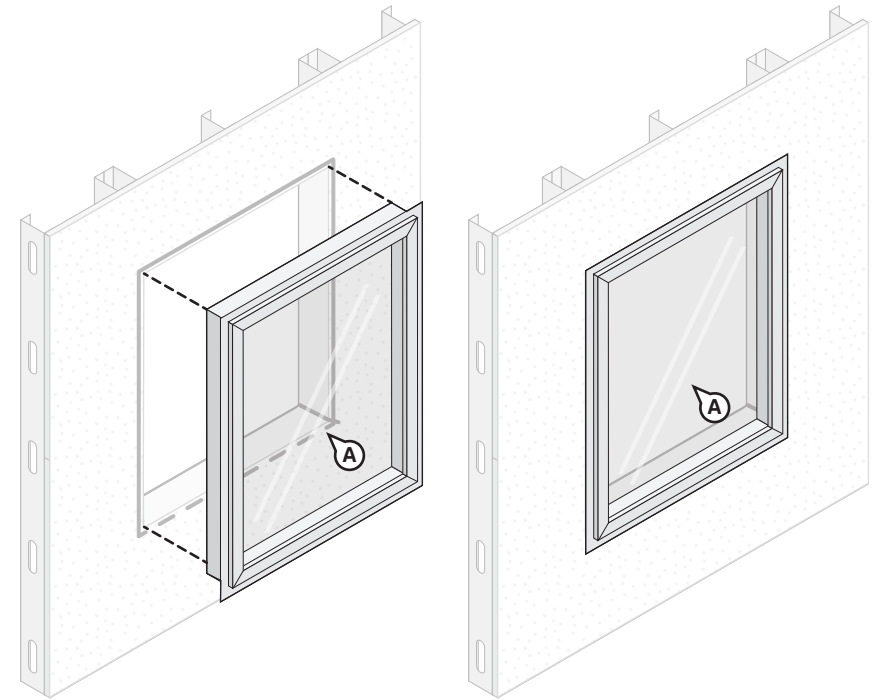

STEP 11

A. Install window per manufacturer's installation instructions.

Installation Methods for DuPont Flashing Products

Steel Stud with Integral Flanged Window

Method 3: Alternate Self-Adhered Flashing Option Using DuPont™ StraightFlash™ Only

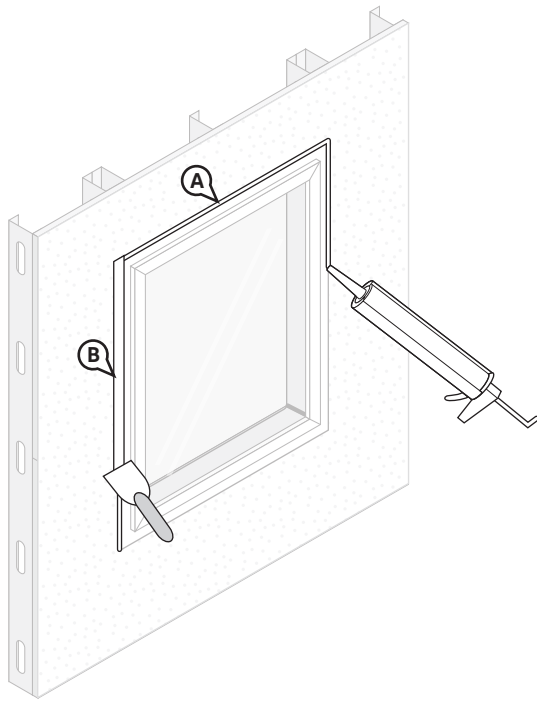

STEP 12

- Apply a continuous bead of **DuPont™ Tyvek® Fluid Applied Flashing and Joint Compound+** along the interface between the window flange and the wall on the jambs and head of the window.
- Use a trowel to smooth flashing to approximately 2" wide x 60 mils thick. The **Tyvek® Fluid Applied Flashing and Joint Compound+** should extend onto the window flange a minimum of a 1/2" past the flange fasteners (approximately 1" onto either side of the flange / wall interface). Upon completion, inspect surface to ensure that **Tyvek® Fluid Applied Flashing and Joint Compound+** application is continuous and **free of any voids or pinholes**.

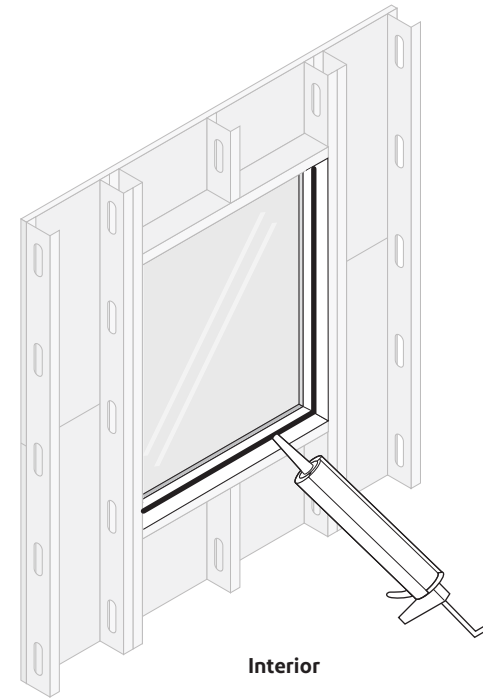

STEP 13

Create Interior Perimeter Seal

Apply a continuous bead of a *chemically-compatible sealant* (and backer rod as necessary) around the window opening at the interior. It is also acceptable to use **Great Stuff Pro™ Window & Door Polyurethane Foam Sealant**, or a chemically-compatible foam. When using **Great Stuff Pro™ Window & Door Polyurethane Foam Sealant** in perimeter openings less than 1/2", apply using the plastic extension tip for the **Great Stuff Pro™ Dispensing Gun** during installation.

NOTE: For high performance installations exceeding ASTM E1677 wind loading pressures (10.8 psf, 65 mph equivalent structural load) and ASTM E331 water infiltration resistance of 6.24 psf, a chemically-compatible sealant **must be** installed over the cured foam when using **Great Stuff Pro™ Window and Door Polyurethane Foam Sealant** or a chemically-compatible foam. Sealant should be installed over the foam between the window frame and rough opening around the entire interior perimeter. If **Great Stuff Pro™ Window and Door Polyurethane Foam Sealant** or other chemically-compatible foam extends beyond the window frame, shave the excess cured foam flush with the window frame before applying sealant. Avoid damaging the **StraightFlash™**.

Installation Methods for DuPont Flashing Products

Packaged Terminal Air Conditioner (PTAC) Unit

This method is for flashing/protecting the rough opening of a Packaged Terminal Air Conditioner (PTAC) Unit.

Method 1: Using DuPont™ Tyvek® Fluid Applied Flashing and Joint Compound+ and DuPont™ StraightFlash™

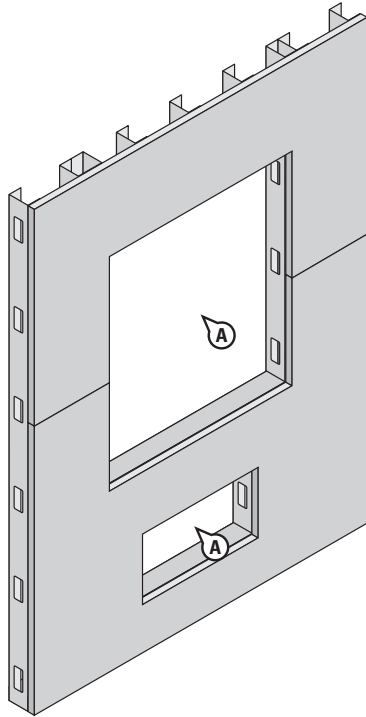

STEP 1

- A. Cut rough openings in sheathing for the PTAC unit and window. Ensure that sheathing is cut flush with, or slightly below the sill framing to allow for positive drainage.

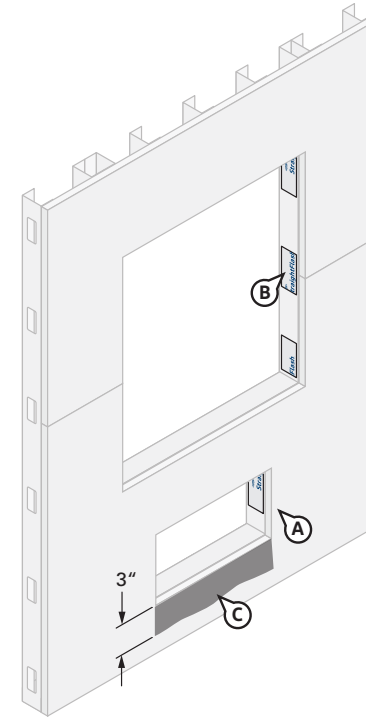

STEP 2

- A. Clean substrate of any material that could negatively affect adhesion as well as any sharp protrusions.
- B. Cover any pre-punched holes in the steel studs with patches of **StraightFlash™**.
- C. When using **StraightFlash™** at the sill, apply a [*chemically-compatible adhesive/primer*](#) approximately 3" onto the exterior face of the wall and along the interior sill for masonry and/or concrete surfaces.

NOTE: If applying to exterior gypsum sheathing, the cut edge of the gypsum should be primed using a [*chemically-compatible adhesive/primer*](#) on all four sides prior to application of **Tyvek® Fluid Applied Flashing and Joint Compound+**.

NOTE: A [*chemically-compatible adhesive/primer*](#) is required when applying **DuPont Self-Adhered Flashing Products** on concrete, masonry, and fiber faced exterior gypsum board substrates. The use of a [*chemically-compatible adhesive/primer*](#), is a recommended best practice for application of **DuPont Self-Adhered Flashing Products** onto wood substrates.

Installation Methods for DuPont Flashing Products Packaged Terminal Air Conditioner (PTAC) Unit

Method 1: Using DuPont™ Tyvek® Fluid Applied Flashing and Joint Compound+ and DuPont™ StraightFlash™

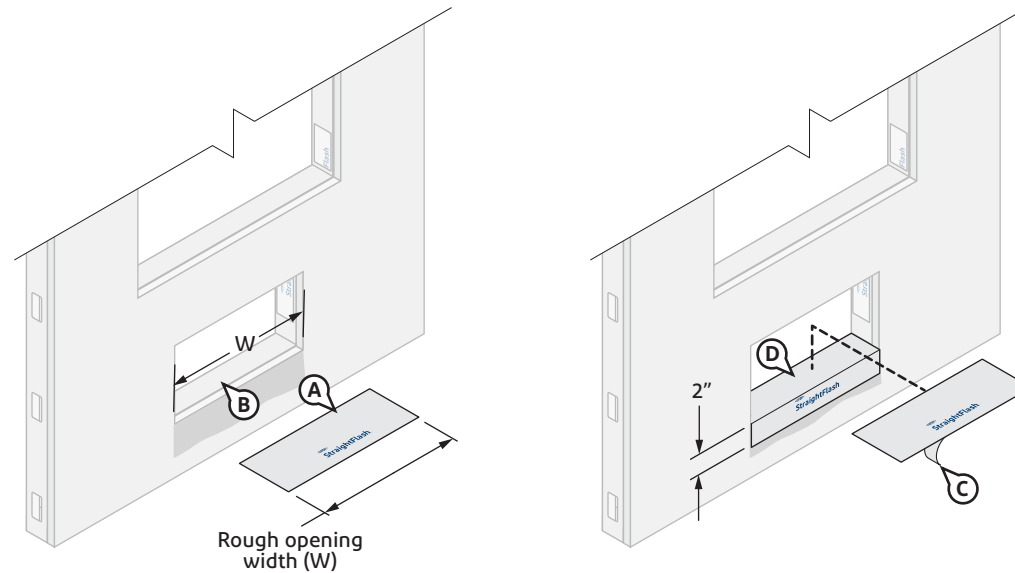

STEP 3

- A. Cut 9" **StraightFlash™** the width of the PTAC rough opening (W). Ensure a minimum of 1" adhesion **BEYOND** where the PTAC frame will be located, and 2"–3" adhesion onto the face of wall.
- B. Inspect installation surface to ensure surface is free of dirt or substances that could interfere with adhesion as well as any sharp protrusions.

- C. Remove the release paper and position **StraightFlash™** onto the sill and 2" minimum onto the face the wall.
- D. Apply pressure along the entire surface of **StraightFlash™** for a good bond using firm hand pressure or J-roller (or alternate tool without sharp edges such as a plastic carpet tuck tool) to assist with application of uniform pressure.

NOTE: **StraightFlash™** is not required in cases where no fasteners are being installed through the sill.

NOTE: **DuPont™ FlexWrap™** can be used in place of **StraightFlash™**. When used, **FlexWrap™** should be cut and installed to accommodate the sill, 6" up each jamb, and 2"–3" onto the face of wall.

Installation Methods for DuPont Flashing Products Packaged Terminal Air Conditioner (PTAC) Unit

Method 1: Using DuPont™ Tyvek® Fluid Applied Flashing and Joint Compound+ and DuPont™ StraightFlash™

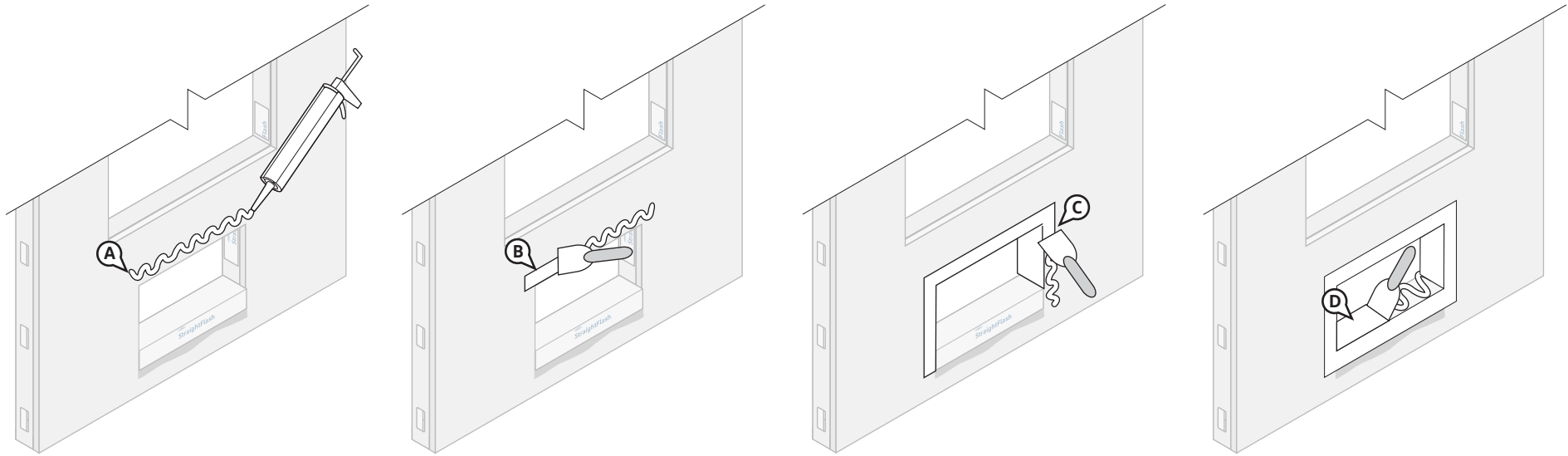

STEP 4

- A. Starting at the head of the PTAC opening, apply a bead of **Tyvek® Fluid Applied Flashing and Joint Compound+** onto the inside surface of the rough opening and onto the face of wall.
- B. Use a trowel or brush to smooth out flashing to a thickness of approximately 25 mils. The flashing should cover the inside of the rough opening and extend a minimum of 2" onto the face of wall.

- C. Continue the application process outlined in STEP 4B for the jambs.
- D. Apply **Tyvek® Fluid Applied Flashing and Joint Compound+** on top of the **StraightFlash™** along the sill and a minimum 2" on the face of wall substrate. Be sure all inside corners are filled and integrated with the **StraightFlash™**. A corner trowel may be used to smooth outside corners.

NOTE: **Tyvek® Fluid Applied Flashing and Joint Compound+** is not required along the entire sill when **StraightFlash™** is installed as previously captured, provided **Tyvek® Fluid Applied Flashing and Joint Compound+** is applied a minimum 4"– 6" along the sill from the jamb corner.

NOTE: If **DuPont™ FlexWrap™** is used along the sill, **Tyvek® Fluid Applied Flashing and Joint Compound+** is not required along the sill to jamb interface but must have 2" min overlap with **FlexWrap™** extending up the jambs and be applied to head and jamb areas.

Installation Methods for DuPont Flashing Products

Packaged Terminal Air Conditioner (PTAC) Unit

Method 1: Using DuPont™ Tyvek® Fluid Applied Flashing and Joint Compound+ and DuPont™ StraightFlash™

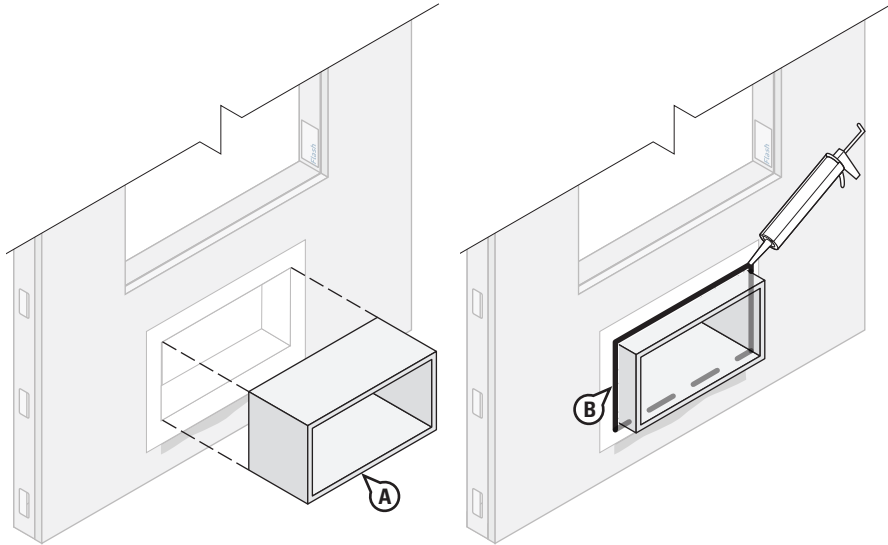

STEP 5

Install PTAC Unit

- Install PTAC Unit sleeve per manufacturer's installation instructions.
- Apply an exterior perimeter seal using backer rod and a [chemically-compatible sealant](#) along the jambs and head of the PTAC opening.

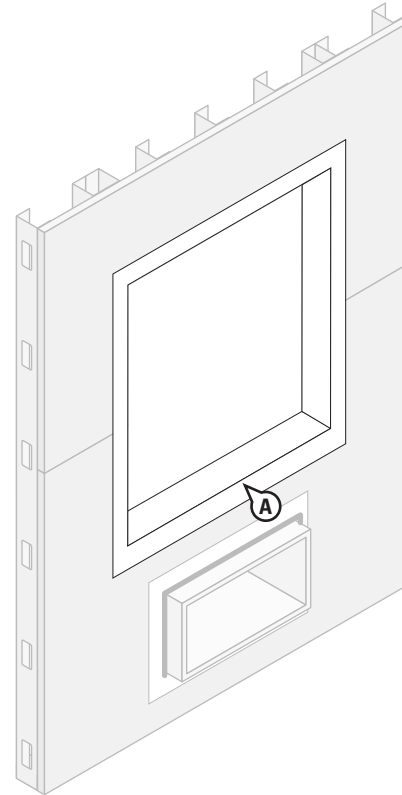

STEP 6

A. Prepare window rough opening and flash per the [Storefront Window; Method 2: Self-Adhered Flashing Using DuPont™ FlexWrap™ and DuPont™ StraightFlash™](#) details section in this guide.

NOTE: A non-flanged window is shown. If an integral flanged window is installed above the PTAC unit, follow the applicable section within this guide.

Installation Methods for DuPont Flashing Products Packaged Terminal Air Conditioner (PTAC) Unit

Method 1: Using DuPont™ Tyvek® Fluid Applied Flashing and Joint Compound+ and DuPont™ StraightFlash™

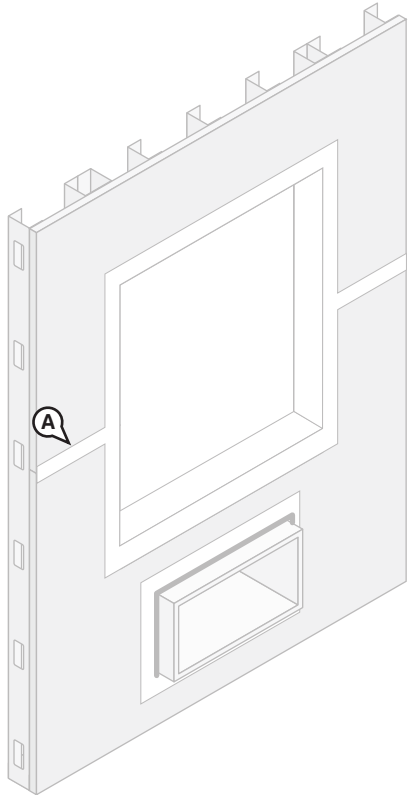

STEP 7

- A. Treat sheathing seam joints with **DuPont™ Tyvek® Fluid Applied Flashing and Joint Compound+** in accordance with the [Joint Treatment Methods](#) where applicable.

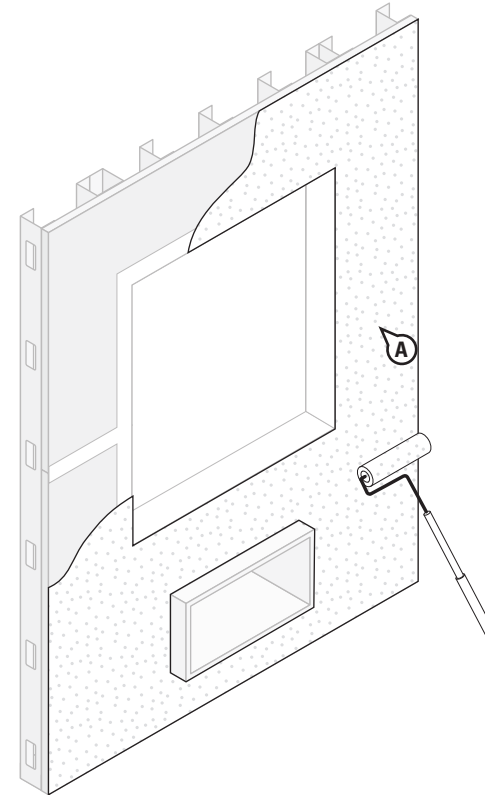

STEP 8

- A. Install **Tyvek® Fluid Applied WB+™** at 25 mils thick up to the edge of the rough opening, overlapping the **Tyvek® Fluid Applied Flashing and Joint Compound+**.

NOTE: When spraying, the outer edge of **DuPont Self-Adhered Flashing Product** should be treated with **Tyvek® Fluid Applied Flashing and Joint Compound+** or **Tyvek® Fluid Applied WB+™** tapered to the wall substrate to help ensure installation is free of pinholes and voids.

Refer to the [DuPont™ Tyvek® Fluid Applied WB+™ Installation Instructions](#) section of this document. Exterior insulation and/or cladding may be installed once the membrane has cured sufficiently to resist damage during installation. Skin time is 1 – 2 hours, and 25 mil is workable in 24 hours at 70°F (20°C), 50% RH.

Installation Methods for DuPont Flashing Products Packaged Terminal Air Conditioner (PTAC) Unit

Method 1: Using DuPont™ Tyvek® Fluid Applied Flashing and Joint Compound+ and DuPont™ StraightFlash™

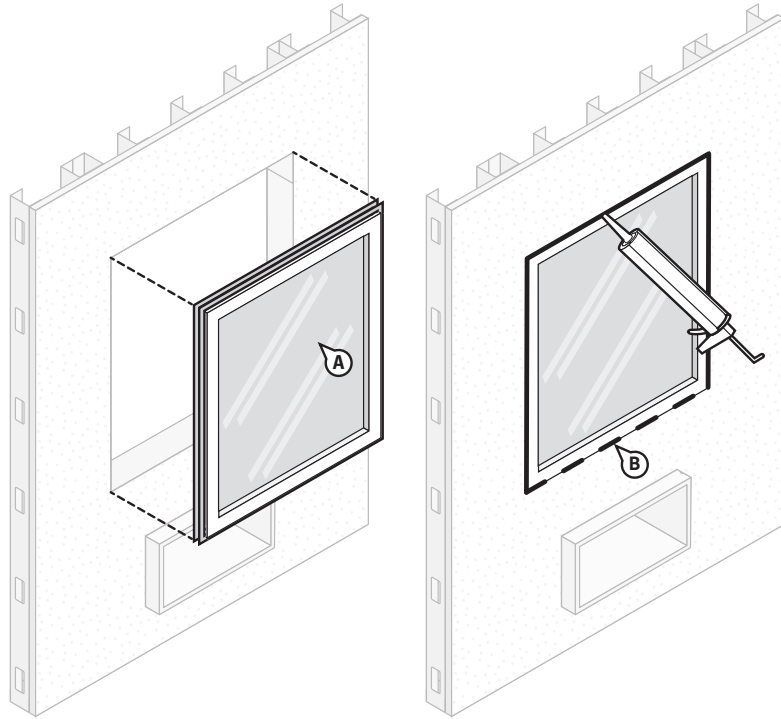

STEP 9

- Install window per manufacturer's installation instructions.
- Apply an exterior perimeter seal using backer rod and a [chemically-compatible sealant](#) along the jambs and head of the window opening.

NOTE: To allow for drainage, do not apply continuous sealant bead along sill. Ensure a minimum 2" wide drainage gap in the sealant bead within 4" from each corner of the jamb-sill interface. Continue applying sealant along the sill with additional 2" wide (min.) drainage gaps for every 6"- 12" (on center) of sill width.

NOTE: A non-flanged window is shown. If an integral flanged window is installed above the PTAC unit, follow the applicable section within this guide.

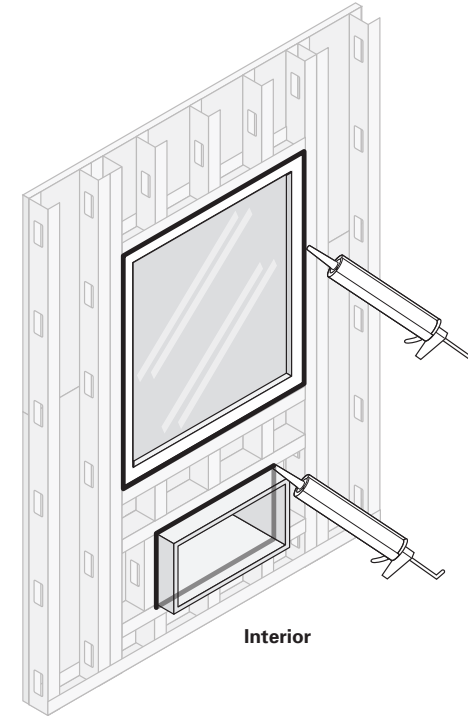

STEP 10

Create Interior Perimeter Seal

Apply a continuous bead of a [chemically-compatible sealant](#) (and backer rod as necessary) around both the window and the PTAC openings at the interior. It is also acceptable to use **Great Stuff Pro™ Window & Door Polyurethane Foam Sealant**, or a chemically-compatible foam. When using **Great Stuff Pro™ Window & Door Polyurethane Foam Sealant** in perimeter openings less than 1/2", apply using the plastic extension tip for the **Great Stuff Pro™ Dispensing Gun** during installation.

NOTE: For high performance installations exceeding ASTM E1677 wind loading pressures (10.8 psf, 65 mph equivalent structural load) and ASTM E331 water infiltration resistance of 6.24 psf, it is necessary to install sealant over the cured foam when using **Great Stuff Pro™ Window and Door Polyurethane Foam Sealant** or a chemically-compatible foam. Sealant should be installed over the foam between the window frame and rough opening around the entire interior perimeter. If **Great Stuff Pro™ Window and Door Polyurethane Foam Sealant** or other chemically-compatible foam extends **BEYOND** the window frame, shave the excess cured foam flush with the window frame before applying sealant. Avoid damaging the **Tyvek® Fluid Applied Flashing and Joint Compound+** and/or **DuPont Self-Adhered Flashing Products**.

Installation Methods for DuPont Flashing Products

Packaged Terminal Air Conditioner (PTAC) Unit

This method is for flashing/protecting the rough opening of a Packaged Terminal Air Conditioner (PTAC) Unit.

Method 2: “Wrap the Cavity” Method Using DuPont™ FlexWrap™ and DuPont™ StraightFlash™

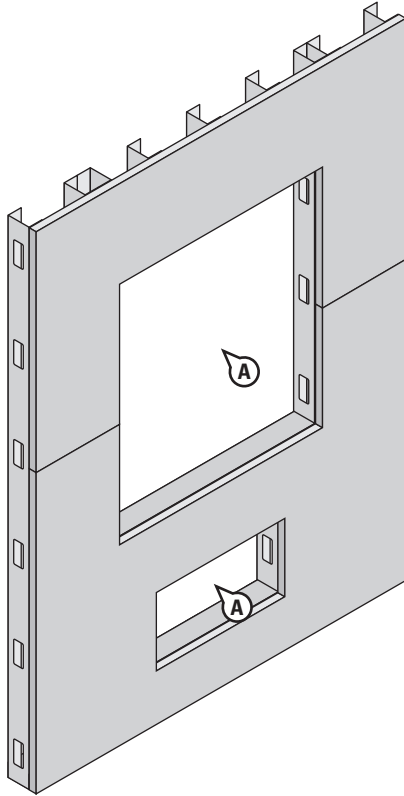

STEP 1

A. Cut rough openings in sheathing for the PTAC unit and window.. Ensure that sheathing is cut flush with, or slightly below the sill framing to allow for positive drainage.

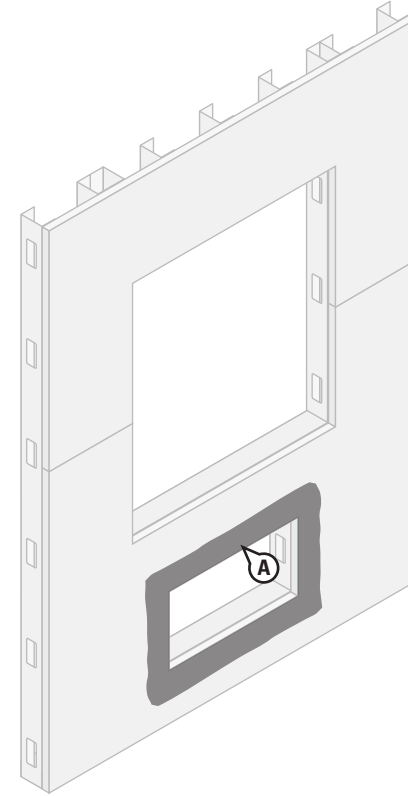

STEP 2

A. Apply a [*chemically-compatible adhesive/primer*](#) to the approximately 3” onto the face of wall around the rough opening for the PTAC Unit.

Installation Methods for DuPont Flashing Products Packaged Terminal Air Conditioner (PTAC) Unit

Method 2: “Wrap the Cavity” Method Using DuPont™ FlexWrap™ and DuPont™ StraightFlash™

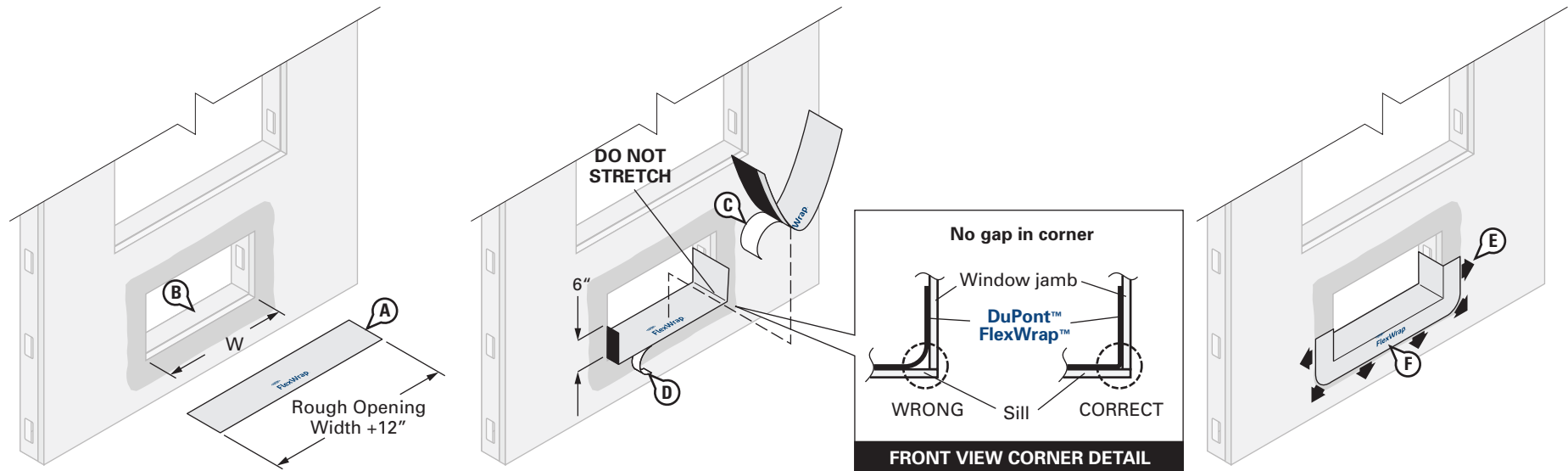

STEP 3

- A. Cut **FlexWrap™** at least 12" **LONGER** than width of rough opening (W). Use 6" **FlexWrap™** for 2" x 4" framing and 9" **FlexWrap™** for 2" x 6" framing.
- B. Inspect installation surface to ensure surface is free of dirt or substances that could interfere with adhesion as well as any sharp protrusions.
- C. Remove wide piece of release paper. Position on horizontal sill by aligning the inside edge of the narrow release paper with the face of wall to ensure 2"– 3" of the **FlexWrap™** will be adhered to the face of wall with a minimum of 6" up each jamb. Adhere into rough opening.
- D. Remove narrow release paper.
- E. Fan out the **FlexWrap™** at corners and adhere onto face of wall. Continue adhering onto face of wall along sill.
- F. Firmly press sill flashing to ensure full adhesion on all surfaces. Eliminate wrinkles and bubbles by smoothing surface and repositioning as necessary.

Installation Methods for DuPont Flashing Products Packaged Terminal Air Conditioner (PTAC) Unit

Method 2: “Wrap the Cavity” Method Using DuPont™ FlexWrap™ and DuPont™ StraightFlash™

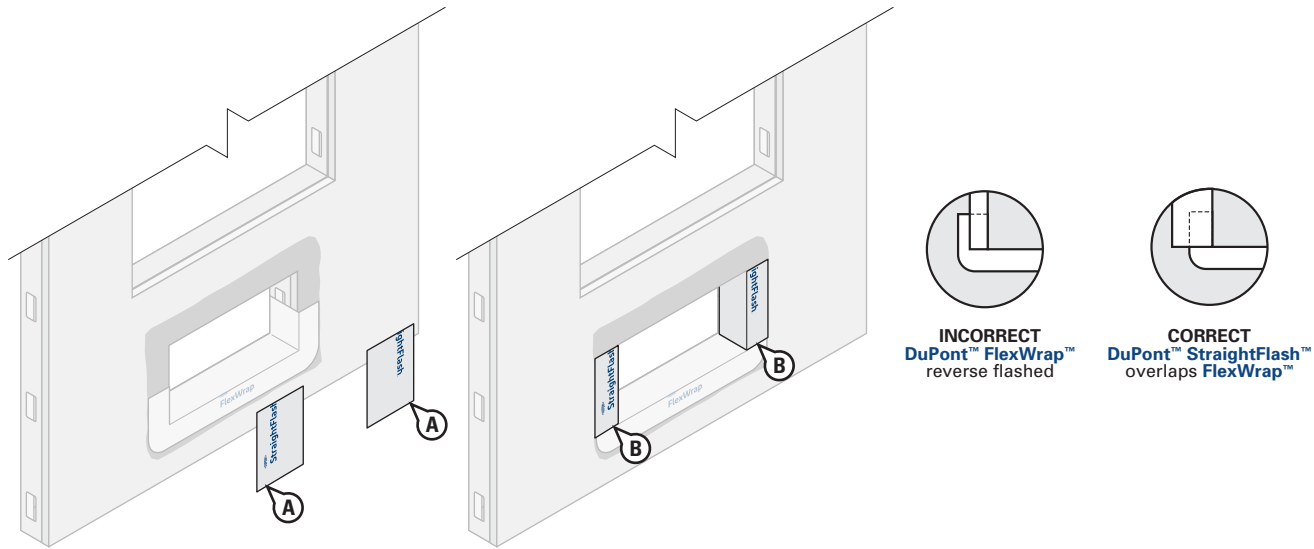

STEP 4

- A. Cut two pieces of 9" **StraightFlash™** the height of the rough opening for the PTAC Unit. Jamb flashing should be long enough to overlap the sill flashing by at least 2" and be overlapped by future head flashing by at least 2".
- B. Wrap the **StraightFlash™** into the rough opening at each jamb and onto wall face. As a general reference, the flashing should align with the interior edge of the jamb framing.

Installation Methods for DuPont Flashing Products Packaged Terminal Air Conditioner (PTAC) Unit

Method 2: “Wrap the Cavity” Method Using DuPont™ FlexWrap™ and DuPont™ StraightFlash™

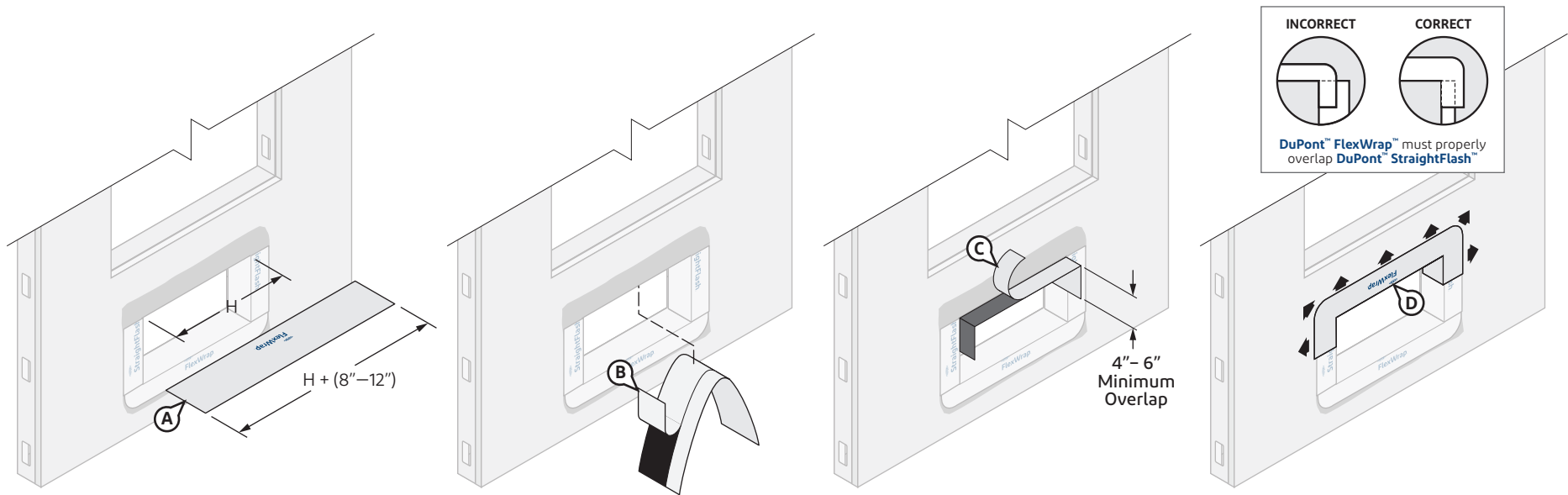

STEP 5

Install FlexWrap™ along the Head of PTAC Unit

- A. Cut **FlexWrap™** at least 8”– 12” **LONGER** than the width of rough opening head (H). Use roll widths sufficient to achieve a minimum of 1” adhesion **BEYOND** where the window frame will be located, ensuring 2”– 3” adhesion onto the face of wall.
- B. Fold the **FlexWrap™** in half lengthwise to create a slight crease at the center. Remove the wide piece of release paper on one side of the fold. Align the inside edge of the narrow release paper with the face of wall to ensure 2”– 3” of the **FlexWrap™** will be adhered to the face of wall. Starting at the crease, adhere the **FlexWrap™** at the center of the horizontal portion of the head framing to ensure a minimum of 4”– 6” down each jamb. Adhere into rough opening at one corner and down the jamb. Remove the remaining release paper and repeat at opposite corner.
- C. Remove narrow release paper.
- D. Fan out the **FlexWrap™** at corners and adhere onto face of wall. Continue adhering onto face of wall along the head.

NOTE: DuPont™ Tyvek® Commercial Certified Installers may install a 3-piece head (and sill) detail for PTAC and window openings less than 6 ft wide. Installers who **are not** DuPont™ Tyvek® Commercial Certified Installers should refer to the [Special Considerations](#) section for more information regarding the 3-piece head/sill detail. Contact your local DuPont Building Envelope Specialist for more information about the Certified Installer program.

Installation Methods for DuPont Flashing Products Packaged Terminal Air Conditioner (PTAC) Unit

Method 2: “Wrap the Cavity” Method Using DuPont™ FlexWrap™ and DuPont™ StraightFlash™

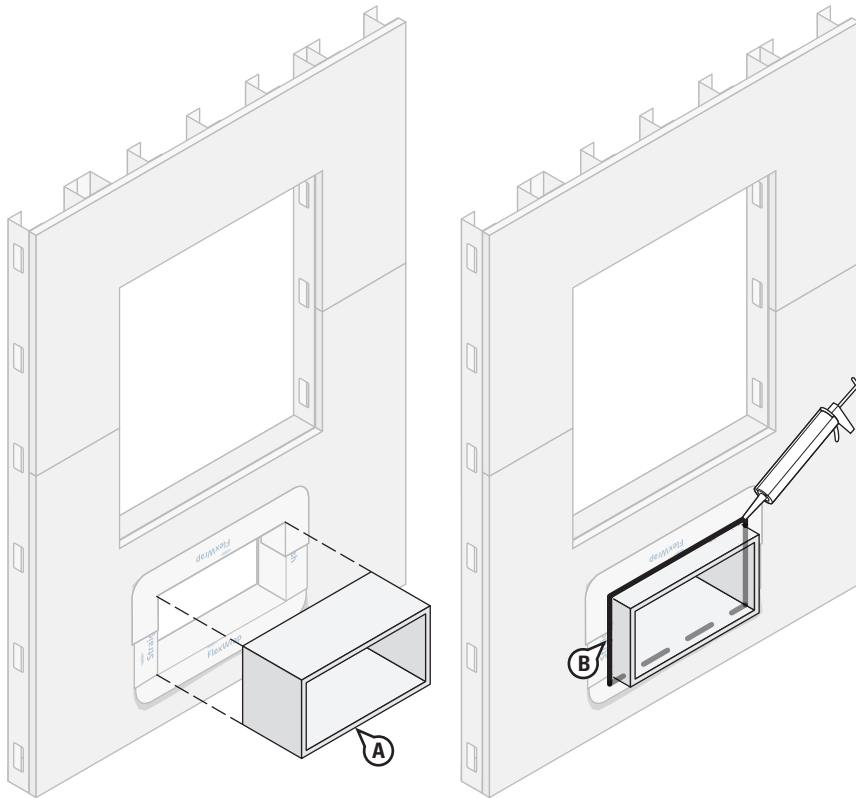

STEP 6

Install PTAC Unit

- A. Install PTAC Unit sleeve per manufacturer’s installation instructions.
- B. Apply an exterior perimeter seal using backer rod and a [chemically-compatible sealant](#) along the jambs and head of the PTAC opening.

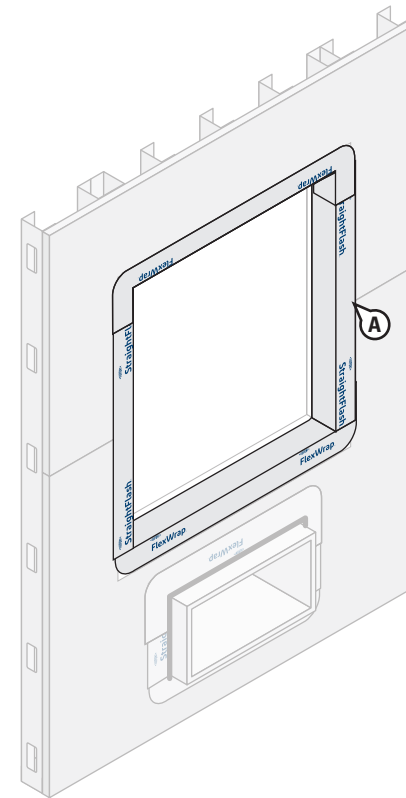

STEP 7

- A. Prepare window rough opening, and flash per the [Storefront Window; Method 2: Self-Adhered Flashing Using DuPont™ FlexWrap™ and DuPont™ StraightFlash™](#) details section in this guide.

NOTE: A non-flanged window is shown. If an integral flanged window is installed above the PTAC unit, follow the applicable section within this guide.

NOTE: For a more robust install, areas with extreme wind load exposures, or high performance testing use 4” **StraightFlash™** to seal the head flap and install additional mechanical fasteners through the flashing at the head flap and perimeter of window.

Installation Methods for DuPont Flashing Products

Packaged Terminal Air Conditioner (PTAC) Unit

Method 2: “Wrap the Cavity” Method Using DuPont™ FlexWrap™ and DuPont™ StraightFlash™

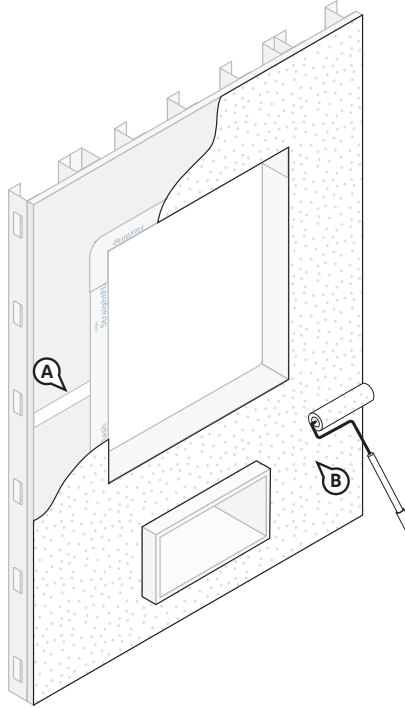

STEP 8

- Treat sheathing seam joints with **DuPont™ Tyvek® Fluid Applied Flashing and Joint Compound+** in accordance with the [Joint Treatment Methods](#) where applicable.
- Install **DuPont™ Tyvek® Fluid Applied WB+™** onto wall at 25 mils thick, overlapping the **DuPont Self-Adhered Flashing Product** up to the edge of the rough opening. Upon completion, inspect all surfaces to ensure that they are covered and free of any voids or pinholes.

NOTES:

- Tyvek® Fluid Applied WB+™** may be applied over and integrated with **Tyvek® Fluid Applied Flashing and Joint Compound+** once a tack-free skin has formed. Skin time is 1–2 hours, and 25 mil is workable in 24 hours at 70°F (20°C), 50% RH.
- When spraying, the outer edge of **DuPont Self-Adhered Flashing Product** should be treated with **DuPont™ Tyvek® Fluid Applied Flashing and Joint Compound+**, and tapered to wall substrate to help ensure installation is free of pinholes and voids..
- Refer to the [DuPont™ Tyvek® Fluid Applied WB+™ Installation Instructions](#) section of this document. Exterior insulation and/or cladding may be installed once the membrane has cured sufficiently to resist damage during installation.

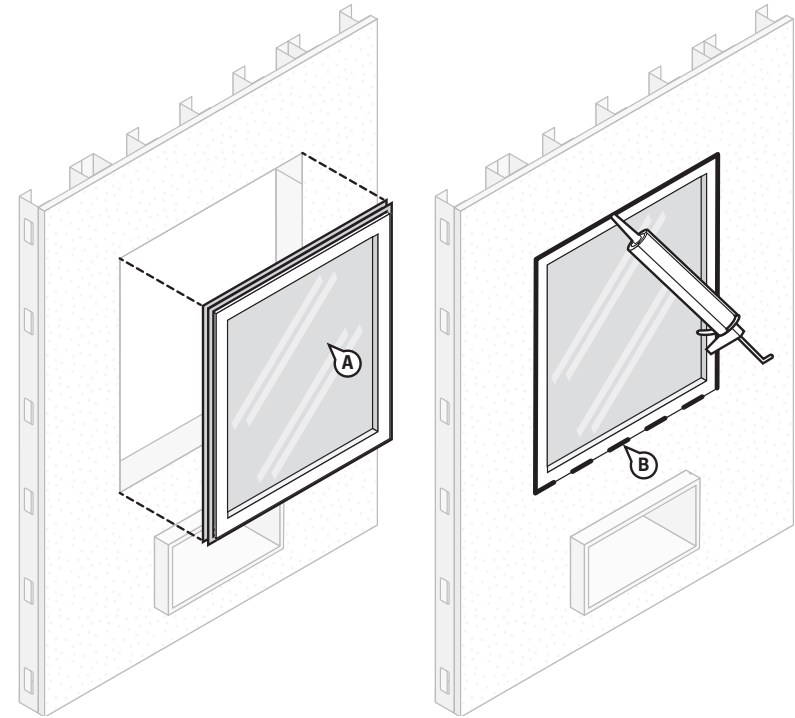

STEP 9

- Install window per manufacturer’s installation instructions.
- Apply an exterior perimeter seal using backer rod and a [chemically-compatible sealant](#) along the jambs and head of the window opening.

NOTE: To allow for drainage, do not apply continuous sealant bead along sill.

Ensure a minimum 2” wide drainage gap in the sealant bead within 4” from each corner of the jamb-sill interface. Continue applying sealant along the sill with additional 2” wide (min.) drainage gaps for every 6”– 12” (on center) of sill width.

NOTE: A non-flanged window is shown. If an integral flanged window is installed above the PTAC unit, follow the applicable section within this guide.

Method 2: “Wrap the Cavity” Method Using DuPont™ FlexWrap™ and DuPont™

Installation Methods for DuPont Flashing Products Packaged Terminal Air Conditioner (PTAC) Unit

StraightFlash™

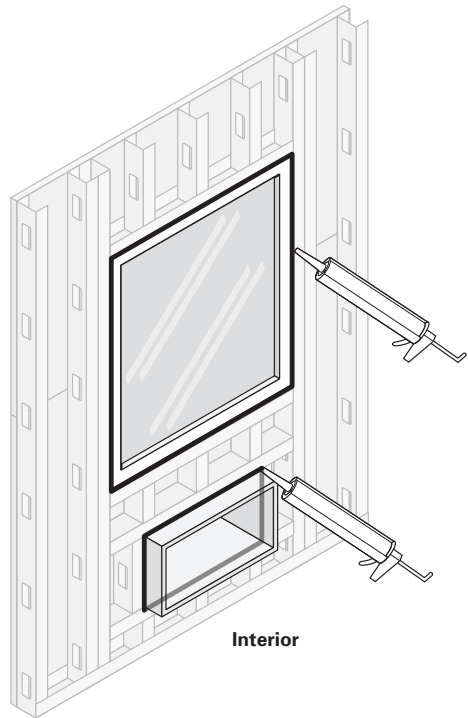

STEP 10

Create Interior Perimeter Seal

Apply a continuous bead of a [chemically-compatible sealant](#) (and backer rod as necessary) around both the window and the PTAC openings at the interior. It is also acceptable to use **Great Stuff Pro™ Window & Door Polyurethane Foam Sealant**, or a chemically-compatible foam. When using **Great Stuff Pro™ Window & Door Polyurethane Foam Sealant** in perimeter openings less than 1/2", apply using the plastic extension tip for the **Great Stuff Pro™ Dispensing Gun** during installation.

NOTE: For high performance installations exceeding ASTM E1677 wind loading pressures (10.8 psf, 65 mph equivalent structural load) and ASTM E331 water infiltration resistance of 6.24 psf, it is necessary to install sealant over the cured foam when using **Great Stuff Pro™ Window and Door Polyurethane Foam Sealant** or a chemically-compatible foam. Sealant should be installed over the foam between the window frame and rough opening around the entire interior perimeter. If **Great Stuff Pro™ Window and Door Polyurethane Foam Sealant** or other chemically-compatible foam extends **BEYOND** the window frame, shave the excess cured foam flush with the window frame before applying sealant. Avoid damaging the **DuPont Self-Adhered Flashing Products**.

Installation Methods for DuPont Flashing Products Through Wall Flashing for Lintel Conditions

Lintel at Window Head (After Installation of DuPont™ Tyvek® Fluid Applied WB+™)

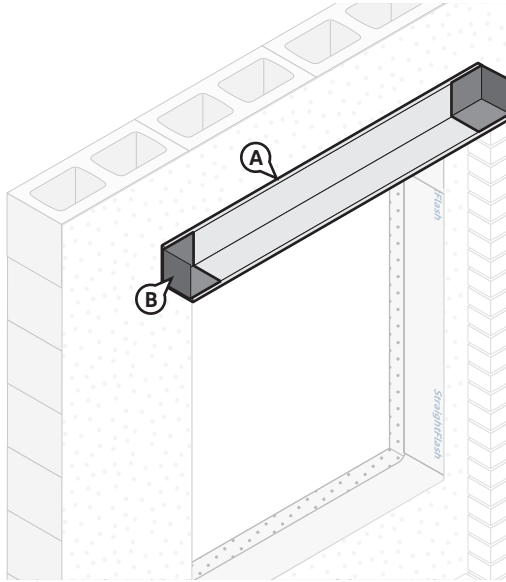

STEP 1

- A. Install lintel on masonry as required.
- B. Install end dams embedded in a [chemically-compatible sealant](#) onto the lintel. End dams should extend a minimum of 4" beyond the edge of the window opening.

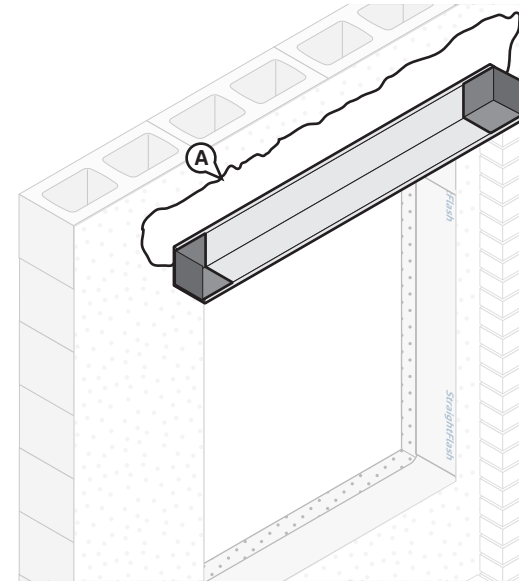

STEP 2

- A. Apply a 25 mil coat of DuPont™ **DuPont™ Tyvek® Fluid Applied Product** onto the face of wall, extending approximately 5" above the lintel.
- B. Cut through wall flashing to the length needed to fit between the end dams. Use wide enough through wall flashing to extend 4" up onto the face of wall when installed.

Installation Methods for DuPont Flashing Products Through Wall Flashing for Lintel Conditions

Lintel at Window Head (After Installation of DuPont™ Tyvek® Fluid Applied WB+™)

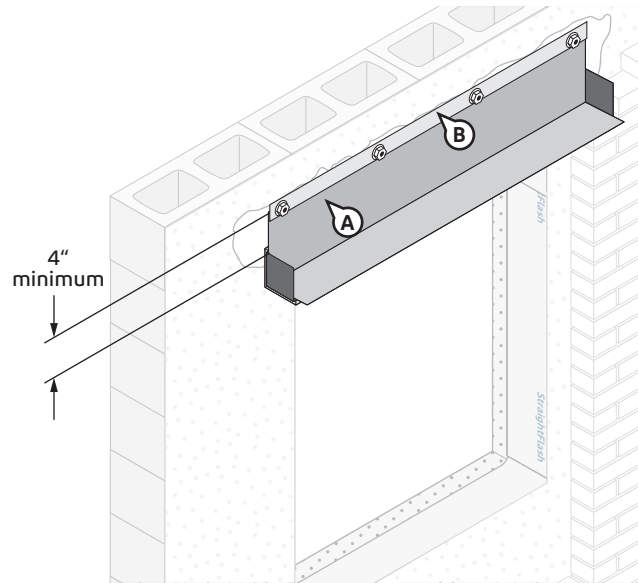

STEP 3

- A. Install through wall flashing on to the wall and lintel with a minimum of 4" adhering to the wall surface.
- B. Terminate the top edge of flashing using mechanical fasteners. As a best practice, DuPont recommends using a termination bar to terminate flashing.

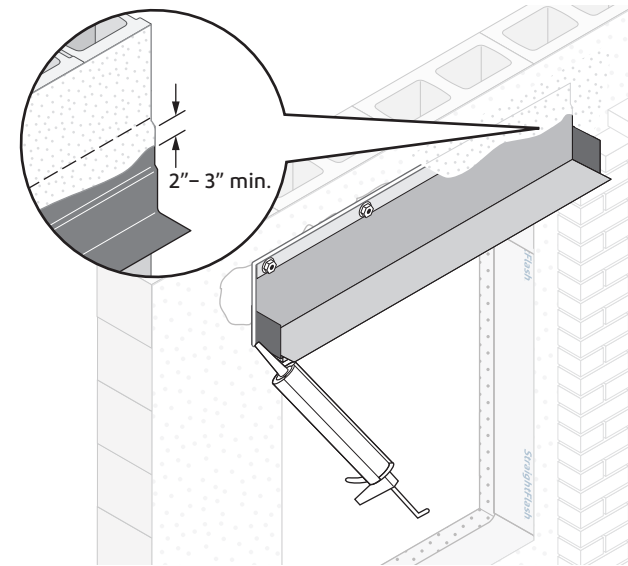

STEP 4

- A. Seal the through wall flashing perimeter, seams, and fasteners using **DuPont™ Tyvek® Fluid Applied Flashing and Joint Compound+** or a [chemically-compatible sealant](#).
- B. Apply a transition coat of **DuPont™ Tyvek® Fluid Applied Product** across the top edge of the through wall flashing membrane and 1"-2" beyond the bottom of the termination bar.

Facade/Exterior Considerations

NOTE: Refer to table in the [Drying/Curing](#) section of this guide for exterior insulation and cladding installation recommendations.

Brick

The Brick Industry Association recommends a 1-inch air space in front of wood stud construction and a 2-inch air space in front of steel stud construction. Consistent with these requirements and recommendations, **DuPont™ Tyvek® Fluid Applied WB+™** shall be separated from the brick veneer by a minimum 1-inch air space. **Tyvek® Fluid Applied WB+™** shall be integrated with window and door flashing and through wall flashing products in accordance with these installation guides. For maximum moisture management and drying of the wall system, the air space in front of the **Tyvek® Fluid Applied WB+™** shall be vented to the exterior at the top and bottom of the wall.

Stucco

The 2024 International Building Code (Section 2510.6) requires “a water-resistive barrier shall be installed as required in Section 1403.2 and shall comply with Section 2510.6.1 or 2510.6.2. Not fewer than one layer of water-resistive barrier material shall be attached to the studs or sheathing, with flashing as described in Section 1404.4, in such a manner as to provide a continuous water-resistive barrier behind the exterior wall veneer. The intersection between the water-resistive barrier material and fenestration openings shall be flashed and assembled in accordance with the fenestration manufacturer’s installation instructions, or other approved methods for applications not addressed by the fenestration manufacturer’s instructions. The water-resistive barrier material shall be continuous to the top of walls and terminated at penetrations and building appendages in a manner to meet the requirements of the exterior wall envelope as described in Section 1402.2. In a two-layer system, the individual layers shall be installed independently such that each layer provides a separate continuous plan and any flashing, installed in accordance with Section 1404.4 and intended to drain to the water-resistive barrier, is directed between the layers”. **Tyvek® Fluid Applied WB+™** should be installed directly over the primary wall substrate and integrated with the window and door flashings, the weep screed at the bottom of the wall and any through wall flashings or expansion joints. **DuPont™ Tyvek® Mechanically Fastened Water-Resistive and Air Barrier (WRB)** can be used as the intervening layer (second layer). Lath shall be installed over the intervening layer in accordance with ASTM C1063-03 *Standard Specification for Installation of Lathing and Furring to Receive Interior and Exterior Portland Cement-Based Plaster* and applicable codes. **DuPont Self-Adhered Flashing Products** or recommended alternate may be required behind lath fasteners for high-performance installations.

Metal Panel

When used with **Tyvek® Fluid Applied WB+™**, metal panel cladding systems shall be installed according to manufacturer’s instructions and industry standards. **Tyvek® Fluid Applied WB+™** shall be integrated with window and door flashing and through wall flashing.

Stone Veneer (or Other Adhered Masonry Veneers)

The 2024 International Building Code (Section 1404.8) requires two layers of a water-resistive barrier in accordance with Section 1403.2. When used behind stone veneer, **Tyvek® Fluid Applied WB+™** shall be installed in a similar manner as it is behind stucco. **Tyvek® Fluid Applied WB+™** should be separated from the stone and mortar by an intervening layer (second layer) of a **Tyvek® Mechanically-Fastened WRB**, a layer of grade D building paper, felt, rigid foam board or the paper backing of paper-backed lath. **Tyvek® Fluid Applied WB+™** should be applied directly over the primary wall substrate and integrated with the window and door flashings, the weep screeds at the bottom of the wall, and any through wall flashings or expansion joints. Lath shall be installed over the intervening layer (second layer) in accordance with ASTM C1063-03 *Standard Specification for Installation of Lathing and Furring to Receive Interior and Exterior Portland Cement-Based Plaster* and applicable codes. **DuPont Self-Adhered Flashing Products** or recommended alternate may be required behind lath fasteners for high-performance installations.

Wood Siding

When used with **Tyvek® Fluid Applied WB+™**, wood siding shall be installed according to manufacturer’s instructions, industry standards and applicable codes. As recommended by the Western Red Cedar Lumber Association and U. S. Forest Product Laboratory, wood siding should be primed on all six sides before installation. In high exposure installations, enhanced drainage and water management may be provided by using **DuPont™ Tyvek® CommercialWrap® D** or by creating rainscreen cladding with a larger air space behind the siding using furring strips. **Tyvek® CommercialWrap® D** offers > 98% drainage efficiency when evaluated in accordance with ASTM E2273 *Standard Test Method for Determining the Drainage Efficiency of Exterior Insulation and Finish Systems (EIFS) Clad Wall Assemblies*. **DuPont™ Tyvek® CommercialWrap®** offers > 90% drainage efficiency when evaluated in accordance with ASTM E2273.

Fiber Cement Siding

When used with **Tyvek® Fluid Applied WB+™**, fiber cement siding shall be installed according to manufacturer’s instructions and industry standards. In high exposure installations, enhanced drainage and water management may be provided by using **Tyvek® CommercialWrap® D** or by creating rainscreen cladding with a larger air space behind the siding using furring strips. **Tyvek® CommercialWrap® D** offers > 98% drainage efficiency when evaluated in accordance with ASTM E2273 *Standard Test Method for Determining the Drainage Efficiency of Exterior Insulation and Finish Systems (EIFS) Clad Wall Assemblies*. **Tyvek® CommercialWrap®** offers > 90% drainage efficiency when evaluated in accordance with ASTM E2273.

Exterior Insulation

Exterior Insulation should be installed after the appropriate flashing materials have been installed and **Tyvek® Fluid Applied WB+™** has been applied and properly integrated with flashing. Exterior insulation shall be installed in accordance with manufacturer’s guidelines and industry standards.

Product Composition and UV Stability

DuPont™ Tyvek® Fluid Applied Products are silyl-terminated polyether based. They are formulated to include elastomeric polymers that cure to a continuous, fully-adhered, tough, durable membrane. Additives have been incorporated to provide ultraviolet light resistance. DuPont requires that the **DuPont™ Tyvek® Fluid Applied WB+™** and **DuPont™ Tyvek® Fluid Applied Flashing and Joint Compound+** are to be covered within 9 months (270 days) of installation.

DuPont Self-Adhered Flashing Products are made from a synthetic rubber adhesive and a top sheet of flash spunbonded high density polyethylene fibers or polypropylene film. Additives have been incorporated into these materials to provide ultraviolet light resistance. DuPont requires that **DuPont™ FlexWrap™**, **DuPont™ FlexWrap™ EZ**, and **DuPont™ StraightFlash™** be covered within nine months (270 days) of installation.

DuPont™ Tyvek® WRBs used in construction products are made from 100% flash spunbonded high density polyethylene fibers which have been bonded together by heat and pressure, without binders or fillers, into a tough durable sheet structure. Additives have been incorporated into the polyethylene to provide ultraviolet light resistance. DuPont requires that **DuPont™ Tyvek® CommercialWrap®** and **Tyvek® CommercialWrap® D** be covered within 9 months (270 days) of installation.

Design Considerations

DuPont Building Envelope Solutions Products are to be used as outlined in this installation guideline. **DuPont Self-Adhered Flashing Products** and **Tyvek® Fluid Applied Flashing and Joint Compound+** should only be used to seal penetrations and flash openings in buildings. **Tyvek® WRBs**, **Tyvek® Fluid Applied Products**, and **DuPont Self-Adhered Flashing Products** are not to be used in roofing applications.

When installed in conjunction with other building materials, **Tyvek® WRBs**, **DuPont Self-Adhered Flashing Products**, and **Tyvek® Fluid Applied Products** must be properly shingled with these materials such that water is diverted to the exterior of the wall system. **Tyvek® WRBs** and **Tyvek® Fluid Applied WB+™** are secondary weather barriers. The outer facade is the primary barrier.

Follow facade manufacturer's installation and maintenance requirements for all facade systems in order to maintain water holdout properties and ensure performance of **Tyvek® WRBs** and **Tyvek® Fluid Applied WB+™**.

Do not install on a wall that does not feature a continuous path for moisture drainage. Any standing water must be allowed to drain off the membrane.

Use of additives, coatings or cleansers on or in the facade system may impact the performance of **Tyvek® WRBs** and **Tyvek® Fluid Applied WB+™**.

For superior protection against bulk water penetration, DuPont suggests a system combining a quality exterior facade, a good secondary air and water barrier and exterior sheathing, high quality windows and doors, and appropriate flashing materials paying attention to proper installation of each component.

Depending on job site conditions, stains may appear on the **Tyvek® Fluid Applied Products**. These discolorations will not alter the products' performance.

Safety and Handling

Warning

Tyvek® Fluid Applied Products may cause irritation. Repeated or prolonged skin contact may cause allergic reactions with susceptible persons. May cause irritation of respiratory tract. **Tyvek® Fluid Applied Products** are mixtures. *Safety and Handling* information is based on the products' components. Refer to each product's Safety Data Sheet (SDS) for further information.

KEEP OUT OF REACH OF CHILDREN.

Children can fall in to bucket and drown. Keep children away from bucket with even a small amount of liquid.

Use only as directed. Avoid inhalation of vapor aerosol.

Caution

Do not handle until all safety precautions have been read and understood. Avoid breathing dust/fumes/gas/mist/vapors/spray. Vapor and aerosols are harmful when using a spray application. If airborne particles are inhaled while spraying, immediately move from exposure to fresh air and contact a physician. Use in a well-ventilated area. A NIOSH approved particulate filtering full-face respirator with a P95 particulate filter or half-mask respirator with a P95 particulate filter and splash impact goggles must be used when spraying. NIOSH-approved N95 disposable safety mask with splash impact goggles can be used for manual application such as troweling or rolling, and for clean-up.

Contaminated work clothing should not be allowed out of the workplace. Wear protective gloves/protective clothing/eye protection/face protection. IF ON SKIN: Wash with plenty of soap and water. IF IN EYES: Rinse cautiously with water for several minutes. Remove contact lenses, if present and easy to do. Continue rinsing. IF EXPOSED OR CONCERNED: Get medical advice/attention. Immediately call a poison center/doctor. IF SKIN IRRITATION OR RASH OCCURS: Get medical advice/ attention. Wash contaminated clothing before reuse. Store locked up. Dispose of contents/ container to an approved waste disposal plant. Avoid contact with eyes and skin.

DuPont Self-Adhered Flashing Products and their release paper are slippery and should not be walked on. Remove release paper from work area immediately.

DuPont Self-Adhered Flashing Products will melt at temperatures greater than 250°F (121°C). **DuPont Self-Adhered Flashing Products** are combustible and should be protected from flames and other high heat sources. **DuPont Self-Adhered Flashing Products** will not support combustion if the heat source is removed. However, if burning occurs, ignited droplets may fall away from the point of ignition. For more information, call 1-833-338-7668.

DuPont™ Tyvek® WRBs are slippery and should not be used in any application where they will be walked on. In addition, because they are slippery, DuPont recommends using kickjacks, scaffolding, or lifts for exterior work above the first floor. If ladders must be used, extra caution must be taken to use them safely by following the requirements set forth in ANSI Standards 14.1, 14.2, and 14.5 for ladders made of wood, aluminum, and fiberglass, respectively.

DuPont™ Tyvek® is combustible and should be protected from flames and other high heat sources. **DuPont™ Tyvek®** will melt at 275°F (135°C) and if the temperature of **DuPont™ Tyvek®** reaches 750°F (400°C), it will burn and the fire may spread and fall away from the point of ignition. For more information, call 1-833-338-7668.

When cured, **Great Stuff Pro™ Window & Door Polyurethane Foam Sealant** is combustible and will burn if exposed to open flame or sparks from high-energy sources. Do not expose to temperatures above 240°F (116°C). For more information, consult (Material) Safety Data Sheet ((M)SDS), call DuPont at 1-866-583-2583. When air sealing buildings, ensure that combustion appliances, such as furnaces, water heaters, wood burning stoves, gas stoves and gas dryers are properly vented to the outside. See website: <https://www.nrel.gov/docs/fy14osti/61326.pdf>.

In Canada visit: <https://nrc-publications.canada.ca/eng/view/ft/?id=96acba7c-afd4-4ea1-94b0-1f8f3500c582>.

Great Stuff Pro™ polyurethane foam sealant and adhesive products contain isocyanate and a flammable blowing agent. Read all instructions and (Material) Safety Data Sheet ((M)SDS), carefully before use. Eliminate all sources of ignition before use. Cover all skin. Wear long sleeves, gloves, and safety glasses or goggles. Not for use in aviation, or food/ beverage contact, or as structural support in marine applications. Provide adequate

ventilation or wear proper respiratory protection. Contents under pressure. Not to be used for filling closed cavities or voids such as behind walls and under tub surrounds; this improper use of the product could result in the accumulation of flammable vapors and/or uncured material. Failure to follow the warnings and instructions provided with the product, and/or all applicable rules and regulations, can result in injury or death.

Building and/or construction practices unrelated to building materials could greatly affect moisture and the potential for mold formation. No material supplied by DuPont can give assurance that mold will not develop in any specific system.

Read all instructions and (Material) Safety Data Sheet ((M)SDS) carefully before use.

For more information, visit greatstuffpro.com or building.dupont.com

Hazard Statement

Tyvek® Fluid Applied Products may cause an allergic skin reaction. May cause serious eye damage. May cause genetic defects. May damage fertility or the unborn child. As it relates to California Prop 65, **Tyvek® Fluid Applied Products** can expose you to substances including Crystalline silica, which is /are known to the State of California to cause cancer. For more information, visit p65Warnings.ca.gov.

For complete warranty information please call 1-833-338-7668 or visit us at building.dupont.com.

For More Information

Visit the *Quick Links* section of our website (<https://www.dupont.com/building/resources.html>) where you'll find links to essential documents and resources to help you get the job done right:

- Installation Guidelines
- Safety Data Sheets (SDS)
- CAD Drawings
- DuPont Performance Building
- Solutions Document Library

For complete warranty information please call 1-833-338-7668 or visit us at building.dupont.com.



For more information about DuPont Performance Building Solutions Systems, please call 1-833-338-7668 or visit us at building.dupont.com

© 2025 DuPont. DuPont™, the DuPont Oval Logo, and all trademarks and service marks denoted with ™, ® or ® are owned by affiliates of DuPont de Nemours, Inc. unless otherwise noted. Graco® is a registered trademark of Graco Inc. Grip-Deck®, Grip-Lok®, and Thermal-Grip FastCap™ are trademarks or registered trademarks of TRUFAST® Walls (formerly Rodenhouse Inc.). 2-Seal™ is a trademark of Hohmann & Barnard, Inc. Heckmann™ and Posi-Tie® are trademarks or registered trademarks of Mechanical Plastics Corp.

43-D101091-enUS-0525